



WARD *Flex*

Design & Installation Guide

WARDFlex-WARDFlex MAX- WARDFlex Underground

WFDI-011019-JANUARY, 2019

www.wardmfg.com (800) 248-1027

www.wardmfg.com (800) 248-1027

WARD Flex[®]

WARD Flex MAX

WARD Flex
UNDERGROUND

Design and Installation Guide

Corrugated Stainless Steel Tubing Fuel Gas* Piping

*Includes Natural Gas and Propane

WARD MFG

P.O. BOX 9
BLOSSBURG, PA. 16912
570 638-2131
WWW.WARDMFG.COM



Rev. 14 JANUARY 2019 ©Ward Manufacturing, LLC. All Rights Reserved.

Written in accordance with ANSI-LC 1 the Standard for Fuel Gas Piping Systems Using Corrugated Stainless Steel Tubing.

TABLE OF CONTENTS

1.0 Introduction	7
1.1 User Warnings	7
1.2 Limitations of Manual	8
1.3 Listing of Applicable Codes and Standards	8
2.0 Description of Systems and Components	9
2.1 System Description	9
2.1.1 WARDFlex Corrugated Stainless Steel Tubing (CSST)	9
WARDFlex Fittings Description	10
2.2 WARDFlex Components	10
2.2.1 WARDFlex Corrugated Stainless Steel Tubing	11
2.2.2 Components	11
Mechanical Joints (Male Straight & Reducing, Female Straight & Reducing)	11
Couplings	12
Mechanical Tees (Straight & Reducing, Female Straight & Reducing)	12
Adapter Nut	13
Termination Fittings (Male Indoor and Outdoor, Female Indoor and Outdoor)	13
Floor Flange Termination Assemblies Male	13
Protection Devices	13
Striker Plates	13
Stripwound Conduit	13
Pressure Regulators	13
Manifolds	14
Shutoff Valves	14
Other Components	15
Appliance, Meter and Fireplace Stubouts	15
Manifold Bracket	15
Right Angle Mounting Bracket	15
Gas Outlet Box	15
Quick Connects	15
Bonding Clamps	15
3.0 System Configuration and Sizing	16
3.1 System Overview	16
3.1.1 Introduction	16
3.1.2 System Design	16
3.2 System Configurations	16
3.2.1 Introduction	16
3.2.2 Series Systems	17
3.2.3 Parallel Systems	17
3.2.4 Dual Pressure Systems	18
3.3 System Sizing	18
3.3.1 Introduction	18
3.3.2 Longest Length Method	18
Low Pressure Parallel System Example	19
Low Pressure Series System Example	20
Dual Pressure Parallel System	21
3.3.3 Equivalent Lengths Factor for Fitting and Valves	21
3.3.4 Summation Sizing Method	22
4.0 Installation Practices	22
4.1 General Installation Practices	22
Bend Radius	22
Chemicals to Avoid	23
4.2 Fitting Assembly	24
4.2.1 WARDFlex Stepsaver Fitting	24
4.2.2 WARDFlex Fitting Reassembly	24
4.2.3 WARDFlex Underground CSST	25
4.3 Tubing Routing	26
4.3.1 Vertical Runs	26
4.3.2 Horizontal Runs	26
4.3.3 Clearance Holes and Notching	26
4.3.4 Concealed Locations For Fittings	27
4.3.5 Modification to Existing System	28
4.3.6 Outdoor Installations	28
4.3.7 Fire Rated Construction	28
Firestop Listings	29
4.4 Protection	30
4.4.1 Introduction	30
4.4.2 Striker Plates	30
4.4.3 Stripwound Metal Conduit	32

4.4.4	Installation in Insulated Walls	32
4.5	Meter-Connections	33
4.5.1	Unsupported Meters	33
4.5.2	Self Supported Meter	34
4.6	Appliance Connections.....	34
4.6.1	Moveable Appliances.....	34
4.6.2	Non-Moveable Appliance	35
4.6.3	Outdoor Appliances-Barbeque Grill and Gas Light Connection.....	36
4.6.4	Special Applications	37
	Roof Top Installations	37
	Infrared Heaters.....	37
	Pad Mounted Gas Appliances	38
4.6.5	Gas Fireplaces	38
4.7	Manifold Station	39
4.8	Pressure Regulators.....	39
4.8.1	Installation Requirements.....	39
4.8.2	Regulator Venting Requirements	41
	Vent Lines	41
4.8.3	Regulator Adjustment	42
4.8.4	Over Pressurization Protection	42
4.9	Underground Installations	42
4.9.1	General Information	42
	Burial Depths and Conduit Termination Height.....	43
4.10	CSST Electrical Bonding	44
5.0	Inspection, Repair and Replacement	45
5.1	Minimum Inspection Requirements (Checklist).....	45
5.2	Repair/Replacement of Damaged Tubing	45
6.0	Testing	47
6.1	Pressure Testing and Inspection Procedure.....	47
7.0	Sizing Tables (Natural and LP) Table of Contents.....	48
7.1	Natural Gas-Low Pressure	48
	Table A-1 Natural Gas-Low Pressure 0.5 PSI or less and Pressure Drop of 0.5 in. WC.....	48
	Table A-2 Natural Gas-Low Pressure 0.5 PSI or less and Pressure Drop of 1.0 in. WC.....	48
	Table A-3 Natural Gas-Low Pressure 0.5 PSI or less and Pressure Drop of 6.0 in. WC	49
	Table A-4 Natural Gas-Low Pressure 0.5 PSI or less and Pressure Drop of 3.0 in. WC	49
7.2	Natural Gas-Elevated Pressure.....	50
	Table A-5 Natural Gas-Elevated Pressure 5.0 PSI and Pressure Drop of 3.5 PSI	50
	Table A-6 Natural Gas-Elevated Pressure 2.0 PSI and Pressure Drop of 1.0 PSI	50
	Table A-7 Natural Gas-Elevated Pressure 10.0 PSI and Pressure Drop of 7.0 PSI	51
	Table A-8 Natural Gas-Elevated Pressure 25.0 PSI and Pressure Drop of 10.0 PSI.....	51
7.3	Propane Gas-Low Pressure.....	52
	Table A-9 Propane Gas-Low Pressure 0.5 PSI or less and Pressure Drop of 0.5 in WC.....	52
	Table A-10 Propane Gas-Low Pressure 0.5 PSI or less and Pressure Drop of 1.0 in WC.....	52
	Table A-11 Propane Gas-Low Pressure 0.5 PSI or less and Pressure Drop of 3.0 in WC.....	53
	Table A-12 Propane Gas-Low Pressure 0.5 PSI or less and Pressure Drop of 6.0 in WC	53
7.4	Propane Gas-Elevated Pressure	54
	Table A-13 Propane Gas-Elevated Pressure 2.0 PSI and Pressure Drop of 1.0 PSI	54
	Table A-14 Propane Gas-Elevated Pressure 5.0 PSI and Pressure Drop of 3.5 PSI	54
	Table A-15 Propane Gas-Elevated Pressure 10.0 PSI and Pressure Drop of 7.5 PSI	55
	Table A-16 Propane Gas-Elevated Pressure 25.0 PSI and Pressure Drop of 10.0 PSI	55
7.5	Steel Pipe Capacities.....	56
	Table A-17 Steel Pipe Natural Gas 0.5 PSI or less and Pressure Drop of 0.5 in. WC	56
	Table A-18 Steel Pipe Propane Gas 0.5 PSI or less and Pressure Drop of 1.0 in. WC	56
8.0	Definitions	84
8.1	Definitions of Terminology in this Guide	57
WARRANTY	59



ATTENTION!



WARNINGS:

1. The installation of WARDFlex Flexible Gas piping must be performed by a trained installer who has successfully completed the WARDFlex® training program. The installer must also meet all qualifications required by the state and/or local administrative authority administering the provisions of the code where the gas piping is installed.
2. All piping systems using WARDFlex shall be designed and installed according to the requirements of this guide.
3. Only WARDFlex components may be used in the system. Components from other CSST systems are not interchangeable. Only components supplied or specified by Ward Manufacturing shall be used.
4. Installation shall be in accordance with local codes, or in their absence, in accordance with the National Fuel Gas Code ANSI Z223.1 in the USA, and CAN/CGA - B149.1 & B149.2 in Canada. In cases where the requirements of this guide are in conflict with the local code, the local code must take precedence, unless the local authority having jurisdiction approves a variance, or change.
5. Inspection, testing, and purging shall be performed according to the procedures in Chapter 8 of the National Fuel Gas Code, ANSI Z223.1, and/or - B149 installation codes or in accordance with local codes.
6. This system and related components shall be used only in gas piping systems where the operating gas pressure does not exceed 25 psig.
7. WARDFlex & WARDFlex MAX® tubing with covering may be installed in or routed through air plenums, ducts, or other areas which may be limited by building codes to materials having maximum ASTM E84 ratings of 25 Flame Spread and 50 Smoke Density. Other procedures are to be followed by the installer to meet local building codes with respect to Flame Spread and Smoke Density regulations for nonmetallic materials.
8. Tubing may be routed through concrete floors or walls, provided it is encased in previously embedded non-metallic, liquid tight conduit approved for underground use.
9. WARDFlex is typically routed:
 - Beneath, through and alongside floor joists
 - Inside interior wall cavities
 - On top of ceiling joists in attic space
10. Carefully unwind and route the tubing from the reel to the required location, making certain not to kink, tangle or apply excessive force.
11. Tubing end must be temporarily capped or taped closed prior to installation to prevent contamination from foreign material.
12. When installing WARDFlex avoid sharp bends, stretching, kinking, twisting, or contacting sharp objects. The tubing shall be replaced if damage occurs.



IMPORTANT - READ ENTIRE MANUAL
This document is the sole property of WARD
MANUFACTURING, LLC.
It shall not be copied or reproduced without the
prior permission of
WARD MANUFACTURING, LLC.



1.0 INTRODUCTION



1.1 USER WARNINGS (see ANSI LC 1-CSA 6.26)

The use of fuel gas can be dangerous. Special attention must be given to the proper design, installation, testing and application of the gas piping system. Sound engineering practices and principles must be exercised, as well as diligent adherence to the proper installation procedures to ensure the safe operation of the piping system. All installed systems must pass customary installation inspections by the local building official having authority prior to being placed into service.

This document is intended to provide the user with general guidance when designing and installing a WARDFlex corrugated stainless steel tubing gas system. Its use with any other gas tubing system is inappropriate and may result in serious bodily injury and property damage. Where local gas or building codes impose greater requirements than this document, you should adhere to the local code requirements. Performance of accessory devices, such as pressure regulators and shut off valves, should be reconfirmed by contacting the accessory device manufacturer and receiving the latest technical data on sizing, installation, and performance.

Improper installation methods or procedures could lead to accidents such as explosions, fires, gas poisoning, asphyxiation, etc. This system shall be installed with strict adherence to this guide as well as local building codes. All installed systems must pass installation inspections by the authorized local building official prior to being placed in service. Ward Manufacturing, LLC shall have no responsibility for any misinterpretation of the information contained in this guide or any improper installation or repair work or other deviation from procedures recommended in this manual, whether pursuant to local building codes or engineering specifications or otherwise.

Only those components designed and made for or specified for use in this system shall be used in its installation. WARDFlex components and tubing shall not be used with other corrugated stainless steel tubing system components from other manufacturers.

WARDFlex shall be used only in gas piping systems where the operating gas pressure does not exceed 25 PSI. Accessories for systems shall be rated for the operating gas pressure used. Thus, for example, accessories for 25 PSI systems shall be rated for 25 PSI service. Performance of accessory devices, such as pressure regulators and shut-off valves should be reconfirmed by contacting the accessory device manufacturer and receiving the latest technical data on sizing, installation and performance.

Certain chemicals are corrosive to WARDFlex. See Section 4.1 of the current manual for more specific information on this topic.

A gas delivery system consisting of WARDFlex offers significant advantages over other gas delivery systems because of its wall dimensions and corrugated design. In contrast to rigid steel pipe, WARDFlex does not require intermediate joints in most installations because the tubing is capable of being installed in one continuous run, reducing not only the total number of joints, but also the potential for leaks at joints. WARDFlex's flexibility also affords more installation options because an installer can avoid existing obstacles, and it eliminates the repetitive measuring, cutting, threading and joint assembly that are common with installation of rigid steel piping systems. WARDFlex's flexibility offers even further safety advantages in geographic areas that are prone to seismic activity because the tubing provides greater flexibility to withstand certain movement of the ground or structural shifts.

Although WARDFlex provides significant advantages over more rigid gas delivery systems, its wall dimensions make it more likely than steel pipe to be punctured by a nail or other sharp objects, or damaged by other extraordinary forces such as a lightning strike, depending on the circumstances. It is well known that lightning is a highly destructive force. Therefore, the user must ensure that the system is properly bonded. Depending upon conditions specific to the location in which the WARDFlex gas piping system is being installed, including but not limited to whether or not the area is prone to lightning, the owner of the structure should consider whether or not a lightning protection system is necessary or appropriate to protect the structure. Lightning protections are beyond the scope of this bulletin, but are covered by NFPA 780, which is the Standard for the Installation of Lightning Protection Systems, and other standards. Consult with your local Building Official to determine if a lightning protection system is warranted. Users of WARDFlex should consider all of the limitations and benefits of WARDFlex for their particular situation. Installers shall provide building owners and electricians with the required WARDFlex Information Card discussing these limitations and benefits.

1.2 LIMITATIONS OF MANUAL

This document is intended to aid the user in the design, installation and testing of WARDFlex Corrugated Stainless Steel Tubing to distribute fuel gas in residential housing units and commercial structures. It would be impossible for this guideline to anticipate and cover every possible variation in housing configurations and construction styles, appliance loads and local restrictions. Therefore, there may be applications which are not covered in this guide. For applications beyond the scope of this guide, contact Ward Manufacturing's Engineering Department. The techniques included within this guide are recommended practice for generic applications. These practices must be reviewed for compliance with all applicable local fuel gas and building codes. Accordingly, where local gas or building codes impose greater requirements than this manual, you should adhere to the local code requirements. This system and related components should be used only as fuel gas piping where the operating gas pressure does not exceed 25 PSI.

In CANADA the installation of CSA-CGA certified WARDFlex flexible gas tubing for natural and propane gas piping systems must be in accordance with the applicable sections of the current CAN/CGA-B 149.1 or .2 installation codes, and the requirements or codes of the local utility or other authority having jurisdiction. All gas components used in conjunction with the gas tubing must be certified for use in Canada.

1.3 LISTING OF APPLICABLE CODES & STANDARDS (SEE WWW.WARDMFG.COM FOR MORE INFORMATION)

Standards

- ANSI LC 1, CSA 6.26 Fuel Gas Piping Systems Using Corrugated Stainless Steel Tubing (CSST)

Listings

- CSA. - Canadian Standard Association Certificate #1004880
- IAPMO - International Association of Plumbing and Mechanical Officials - File Number 3353
- UL - Classified Mark File #R18357
- ICC - International Codes Council ESR-1879 & PMG 1100, ICC PMG-1442

Code Compliance

- BOCA - National Mechanical Code
- ANSI/CABO 2.0 - One and Two Family Dwelling Code
- ICC - International Mechanical Code/International Plumbing Code, IFGC
- NFPA 54- National Fuel Gas Code
- NFPA 58- Standard for the Storage and Handling of Liquefied Petroleum Gasses
- SBCCI - Southern Building Code Congress International
- UMC - Uniform Mechanical Code
- C/UPC TM - California/Uniform Plumbing Code
- Canada Natural Gas and Propane Codes B149.1 and B149.2
- Massachusetts Board of Registration of Plumbers and Gas Fitters approval



IMPORTANT - READ ENTIRE MANUAL
This document is the sole property of
WARD MANUFACTURING, LLC.
It shall not be copied or reproduced without the
prior permission of WARD MANUFACTURING, LLC.



2.0 DESCRIPTION OF SYSTEMS AND COMPONENTS

2.1 SYSTEM DESCRIPTION

2.1.1 WARDFLEX SYSTEM DESCRIPTION

WARDFlex® Tubing:

The WARDFlex® Corrugated Stainless Steel Tubing (CSST) Piping System has been engineered, tested and certified to meet the performance requirements of American National Standard for Fuel Gas Systems Using Corrugated Stainless Steel Tubing, ANSI LC-1. As such is acceptable for use with all recognized fuel gases, including natural gas and propane (LPG).

- Manufactured using a 304 alloy stainless steel per ASTM A240.
- Fully annealed; increasing flexibility, facilitating installation in tight locations, and reduced product memory to avoid rapid uncoiling when unbanned from spools.
- The CSST is jacketed with a non-metallic coating to ease installation when running through studs, joists, and other building components.
- Jacketing material includes UV inhibitors making it suitable for outdoor installations.
- Jacket utilizes flame retardants making it ASTM E84, and ULC S102 compliant.
- Coating is marked at 2 foot intervals allowing for quick measurements.
- WARDFlex® sizes 15A through 50A are certified for working pressures up to 25 PSI. WARDFlex 10A is certified for working pressures up to 5 PSI in accordance with ANSI LC-1, by CSA International.

WARDFlex®MAX Tubing:

The WARDFlex®MAX Corrugated Stainless Steel Tubing (CSST) Piping System has been engineered, tested and certified to meet the performance requirements of American National Standard for Fuel Gas Systems Using Corrugated Stainless Steel Tubing, ANSI LC-1. As such is acceptable for use with all recognized fuel gases, including natural gas and propane (LPG).

- Manufactured using a 304 alloy stainless steel per ASTM A240.
- Fully annealed; increasing flexibility, facilitating installation in tight locations, and reduced product memory to avoid rapid uncoiling when unbanned from spools.
- WARDFlex is jacketed with a non-metallic coating to ease installation when running through studs, joists, & other building components.
- Jacketing material includes UV inhibitors making it suitable for outdoor installations.
- Coating is marked at 2 foot intervals allowing for quick measurements.
- WARDFlex® MAX is certified for working pressures up to 25 PSI in accordance with ANSI LC-1, by CSA International.
- Jacket utilizes flame retardants making it ASTM E84 and ULC S102 compliant

WARDFlex® UNDERGROUND Tubing:

- Meets all requirements of ICC LC1023, Listing Criteria for Polyethylene Jacket Corrugated Stainless Steel Tubing
- Manufactured using a 304 alloy stainless steel per ASTM A240.
- Fully annealed; increasing flexibility, facilitating installation in tight locations, and reduced product memory to avoid rapid uncoiling when unbanned from spools.
- WARDFlex® UG is jacketed with a non-metallic coating to ease installation when running through studs, joists, and other building components.
- Jacketing material includes UV inhibitors making it suitable for outdoor installations.
- Coating is marked at 2 foot intervals allowing for quick measurements.
- WARDFlex UG is certified for working pressures up to 25 psi.

Fittings:

The 3/8" thru 1-1/4" tubing is terminated using the patented, STEPSAVER double seal fitting. The 1-1/2" and 2" utilize the WARDFlex® traditional gasketed fitting design. Only fittings designed and listed for use with the WARDFlex® and WARDFlex®MAX CSST Piping Systems shall be used when connecting to the flexible piping.

- WARDFlex® fittings come standard with ASME B1.20.1 male or female NPT thread connection to be used in combination with other approved fuel gas piping materials with ASME B1.20.1 threaded pipe connections.
- Fittings are manufactured from EN 12164 compliant brass, and ASTM A197 malleable iron. Depending on type of malleable iron fitting, coating will be either black e-coat or electroplated zinc (ASTM B633).
- The 3/8" thru 1-1/4" STEPSAVER fittings provide a reliable, reusable dual seal that features a primary metal to metal seal with a secondary gasket seal.
- The 1-1/2" and 2" fittings utilize a reliable gasket seal. Fitting should be examined prior to reuse for damage to gasket. If the gasket has been damaged during prior assembly it is recommended that it be replaced prior to re-assembly.

Protection Devices:

Protective devices are to be used when CSST passes through studs, joists, or other building materials that limit or restrict the movement of the flexible piping making it susceptible to physical damage from nails, screws, drill bits and other puncture threats

- Case Hardened Striker plates attach directly to studs and joists.
- Strip wound metallic conduit can be used in locations where additional protection may be required.

Pressure Regulators:

Required to be used to reduce elevated pressure, over 14 inches water column (1/2 PSI,) to standard low pressure required for most appliances.

Manifolds:

Multiport gas distribution manifolds supply multiple gas appliances in parallel arrangement from a main distribution point.

- Multiple sizes and configurations ranging in female NPT sizes ½ through 2 with 3, 4 and 6 port cross manifold configurations.
- Material is ASTM A197 Malleable Iron coated with black e-coating finish.

Shutoff Valves:

Used to control the gas flow. Ball valves shut off the gas supply at appliances, manifolds, & regulators. WARDFlex® Valves can be utilized at manifold locations reducing the number of joints due to the integrated WARDFlex® STEPSAVER fitting connection.

Other Components/Accessories:

CSST systems have a variety of hardware and design differences from conventional gas piping systems using rigid steel and copper tubing. To address these differences a variety of accessories are available.

- Appliance and meter stub outs, manufactured from schedule 40 steel pipe and fitted with a steel mounting plate, are used to create a fixed termination point on a wall or floor to allow the attachment of appliances or a meter.
- Manifold Brackets provide a fixed mounting location for manifolds. Material is 16 gauge steel.
- Gas outlet boxes use a WARDFlex® 90 degree valve and a molded plastic mounting box to provide a recessed termination point for the connection of movable appliances. Fire rated outlet box also available.
- Quick connect valves and accessories provide a fixed termination point of the flexible piping system and allow for a quick-connect connection for grills and other outdoor gas powered appliances.
- Bonding clamps are provided and are to be used when performing the required bonding for the WARDFlex® CSST piping system.

2.2 COMPONENTS

2.2.1 WARDFLEX CORRUGATED STAINLESS STEEL TUBING (CSST)



*Custom Lengths Available Upon Request.

Material
Tubing:
304 Stainless Steel
Jacket:
Polyethylene

TUBING Size	DESCRIPTION							
	Item	10A	15A/15C/15U	20A/20C/20U	25A/25C	32A/32C	38A/38C	50A/50C
WARDFlex® WARDFlex®MAX WARDFlex® UNDERGROUND	Size (in.)	3/8"	1/2"	3/4"	1"	1-1/4"	1-1/2"	2"
Equivalent Hydraulic Diameter (EHD)	EHD	15	19	25	31	39	48	62
Inner Dia. - I.D.	In.	0.452	0.591	0.787	0.984	1.26	1.59	2.12
	(mm)	(11.50)	(15.00)	(20.00)	(25.00)	(32.00)	(40.40)	(53.80)
Wall Thickness - t Note WARDFlex®MAX	In.	0.008	.008/.010	0.010	0.010	0.010	0.012	0.012
	(mm)	(0.20)	(.20/.25)	(0.25)	(0.25)	(0.25)	(0.30)	(0.30)
WARDFlex® Outside Diameter of Coating - O.D. (MAX)	In.	0.663	0.828	1.088	1.321	1.636	2.136	2.676μμ
	(mm)	(16.80)	(21.00)	(27.60)	(33.50)	(41.50)	(54.30)	(68.00)
WARDFlex®MAX Outside Diameter of Coating - O.D. (MAX)	In.	N/A	0.832	1.096	1.329	1.644	2.138	2.678
	(mm)		(21.10)	(27.80)	(33.80)	(41.80)	(54.30)	(68.00)
WARDFlex®UNDERGROUND Outside Diameter of Coating	In.	N/A	0.964	1.220	N/A	N/A	N/A	N/A
	(mm)	N/A	(24.5)	(31.0)	N/A	N/A	N/A	N/A
WARDFlex® Available Lengths	(ft)	50*, 100*, 250*, 500*, 1000	26*, 50*, 100*, 250*, 500*, 1000	26*, 50*, 100*, 180*, 250, 500	50*, 100*, 180*, 250, 500	50*, 100*, 250	50, 100, 150	50, 100, 150
WARDFlex®MAX Available Lengths	(ft)	N/A	26* 50*, 100*, 250*, 500, 1000	26* 50*, 100*, 250*, 500 1000	50*, 100*, 250, 500	50*, 100*, 250, 400	50, 100, 150	50, 100, 150
WARDFlex®UG Available Lengths	(ft)	N/A	100, 250	100, 250	N/A	N/A	N/A	N/A

2.2.2 FITTINGS













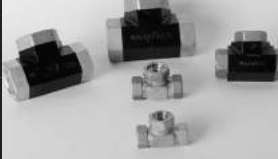



Mechanical Joints Male - Straight	
Material	Body: Brass Retainer: Brass Nut: Brass Gasket: Composite Fiber
CSST x NPS	10M (3/8") x 3/8 15M (1/2") x 1/2 20M (3/4") x 3/4 25M (1") x 1 32M (1 1/4") x 1 1/4 38M (1 1/2") x 1 1/2 50M (2") x 2











Mechanical Joints Male - Reducing	
Material	Body: Brass Retainer: Brass Nut: Brass Gasket: Composite Fiber
CSST x NPS	10M (3/8") x 1/2 15M (1/2") x 3/8 20M (3/4") x 1/2 25M (1") x 3/4

2.2.2 FITTINGS

	Mechanical Joints Female - Straight	
	Material	Body: Brass Retainer: Brass Nut: Brass Gasket: Composite Fiber
	CSST x NPS	15M (1/2") x 1/2 20M (3/4") x 3/4 25M (1") x 1
	Mechanical Joints Female - Reducing	
	Material	Body: Brass Retainer: Brass Nut: Brass Gasket: Composite Fiber
	CSST x NPS	10M (3/8") x 3/8 15M (1/2") x 1/2 20M (3/4") x 3/4 25M (1") x 1 32M (1 1/4") x 1 1/4 38M (1 1/2") x 1 1/2 50M (2") x 2
	Couplings	
	Material	Body: Brass Retainer: Brass Nut: Brass Gasket: Composite Fiber
	CSST x NPS	10M (3/8") x 10M (3/8") 15M (1/2") x 15M (1/2") 20M (3/4") x 20M (3/4") 25M (1") x 25M (1") 32M (1 1/4") x 32M (1 1/4") 38M (1 1/2") x 38M (1 1/2") 50M (2") x 50M (2")
	Mechanical Tees - Straight - CSST x CSST x CSST	
	Material	Body: Brass/Malleable Iron Retainer: Brass Nut: Brass Gasket: Composite Fiber
	CSST	15M (1/2") 20M (3/4") 25M (1") 32M (1 1/4") 38M (1 1/2") 50M (2")
	Mechanical Tees - Reducing - CSST x CSST x CSST	
	Material	Body: Brass/ Malleable Iron Retainer: Brass Nut: Brass Gasket: Composite Fiber
	CSST x CSST x CSST	15M (1/2") x 15M (1/2") x 10M (3/8") 15M (1/2") x 10M (3/8") x 10M (3/8") 20M (3/4") x 20M (3/4") x 15M (1/2") 25M (1") x 25M (1") x 20M (3/4") 25M (1") x 20M (3/4") x 20M (3/4") 25M (1") x 25M (1") x 15M (1/2")
	NEW- WARDFlex Underground Fittings	
	Material	Body: Brass/ Malleable Iron Retainer: Brass Nut: Brass Gasket: Composite Fiber O Rings: EPDM Rubber, Plug: Steel
	CSST X CSST X NPS	15M (1/2") x 1/2" 20M (3/4") x 3/4"
	Mechanical Tees - Female - Straight CSST x CSST x NPS	
	Material	Body: Brass/ Malleable Iron Retainer: Brass Nut: Brass Gasket: Composite Fiber
	CSST X CSST X NPS	15M (1/2") x 15M (1/2") x 1/2 20M (3/4") x 20M (3/4") x 3/4 25M (1") x 25M (1") x 1 32M (1 1/4") x 32M (1 1/4") x 1 1/4 38M (1 1/2") x 38M (1 1/2") x 1 1/2 50M (2") x 50M (2") x 2
	Mechanical Tees - Female - Reducing CSST x CSST x NPS	
	Material	Body: Brass/ Malleable Iron Retainer: Brass Nut: Brass Gasket: Composite Fiber
	CSST X CSST X NPS	15M (1/2") x 15M (1/2") x 3/8 15M (1/2") x 15M (1/2") x 3/4 20M (3/4") x 20M (3/4") x 1/2 20M (3/4") x 20M (3/4") x 1/2 25M (1") x 25M (1") x 3/4

	Adapter Nut	
	Material	Nut: Brass Lockout: Steel
	CSST x NPS	10M (3/8") x 3/4 15M (1/2") x 3/4 20M (3/4") x 1
	Termination Fittings- Male (Indoor and Outdoor) *Outdoor models supplied with o-rings	
	Material	Body: Brass Retainer: Brass Nut: Malleable Iron Gasket: Composite Fiber O-rings: EPDM Rubber
	CSST x NPS	10M (3/8") x 1/2 15M (1/2") x 1/2 20M (3/4") x 3/4 25M (1") x 3/4 25M (1") x 1
	Termination Fittings- Female (Indoor and Outdoor) *Outdoor models supplied with o-rings	
	Material	Body: Brass Retainer: Brass Nut: Malleable Iron Gasket: Composite Fiber O-rings: EPDM Rubber
	CSST X NPS	10M (3/8") x 1/2 15M (1/2") x 1/2 20M (3/4") x 3/4 25M (1") x 3/4 25M (1") x 1
	Flange Termination Fittings- Male (Indoor and Outdoor) *Outdoor models supplied with o-rings	
	Material	Body: Brass Retainer: Brass Nut: Malleable Iron Gasket: Composite Fiber O-rings: EPDM Rubber
	CSST X NPS	10M (3/8") x 1/2 15M (1/2") x 1/2 20M (3/4") x 3/4 25M (1") x 3/4 32M (1 1/4") x 1 1/4 38M (1 1/2") x 1 1/2 50M (2") x 2
	Floor Flange Termination Assemblies- Male	
	Material	Body: Brass Retainer: Brass Nut: Malleable Iron Gasket: Composite Fiber
	CSST X NPS	10M (3/8") x 1/2 15M (1/2") x 1/2 20M (3/4") x 3/4 25M (1") x 1
	Striker Plates	
	Material	Case Hardened Steel
	Available Sizes	Quarter: 1 1/2" W x 3 1/2" L Half: 2 3/4" W x 6 1/2" L Full: 2 3/4" W x 11 1/2" L Extended: 2 3/4" W x 13" L Double Top: 2 3/4" W x 7 1/4" L Large: 3 1/4" W x 17 1/2" L
	Stripwound Conduit	
	Material	Galvanized Steel
	Available Sizes	Size (Length) 3/8" (1' and 50' L) 1/2" (1' and 50' L) 3/4" (1' and 50' L) 1" (1' and 50' L) 1 1/4" (1' and 50' L)
	2 PSI Line Pressure Regulators - Natural Gas (Preset to 8" W.C outlet pressure)	
	Material	Aluminum
	Available Sizes	325 3D: Port Size - 1/2 NPS x 1/2 NPS Vent Size: 1/8 NPS 325 5E: Port Size - 3/4 NPS x 3/4 NPS Vent Size: 3/8 NPS 325 71B: Port Size - 3/4 NPS x 3/4 NPS Vent Size: 1/2 NPS

	2 PSI Line Pressure Regulators - Propane (Preset to 11" W.C outlet pressure)	
	Material	Aluminum
	Available Sizes	325 3DLP: Port Size - 1/2 NPS x 1/2 NPS Vent Size: 1/8 NPS 325 5ELP: Port Size - 3/4 NPS x 3/4 NPS Vent Size: 3/8 NPS
	5 PSI Line Pressure Regulators - Natural Gas (preset at 8" W.C outlet pressure)	
	Material	Aluminum
	Available Sizes	325 3D OP: Port Size - 1/2 NPS x 1/2 NPS Vent Size: 1/8 NPS 325 5E OP: Port Size - 3/4 NPS x 3/4 NPS Vent Size: 3/8 NPS
	3 Port Manifold	
	Material	Body: Malleable Iron
	Available Sizes	1/2 NPS x (3) 1/2 NPS Outlets 3/4 NPS x (3) 1/2 NPS Outlets
	4 Port Manifold	
	Material	Body: Malleable Iron
	Available Sizes	- 1/2 NPS x (4) 1/2 NPS Outlets - 3/4 NPS x (4) 1/2 NPS Outlets - 3/4 NPS x (1) 3/4 NPS & (3) 1/2 NPS Outlets - 1 NPS x (4) 3/4 NPS Outlets - 2 x 1 1/2 NPS x (4) 1 NPS Outlets
	Cross Manifold	
	Material	Body: Malleable Iron
	Available Sizes	- 1/2 NPS x (6) 1/2 NPS Outlets - 3/4 NPS x (4) 1/2 NPS & (2) 3/4 NPS Outlets - 1 x 3/4 NPS x (4) 1/2 NPS & (2) 3/4 NPS Outlets - 1 1/4 x 1 NPS x (4) 1/2 NPS & (2) 3/4 NPS Outlets
	AGA/CSA Approved Gas Valves	
	Material	Body: Brass
	CSST X NPS	- 1/2 NPS - 3/4 NPS
	WARDFlex Valve Assembly	
	Material	Body: Brass Retainer: Brass Nut: Brass Gasket: Composite Fiber
	CSST X NPS	- 10M (3/8") x 1/2 - 15M (1/2") x 3/4 - 20M (3/4") x 3/4 - 25M (1") x 3/4
	WARDFLEX Right Angle Valve Assembly	
	Material	Body: Brass Retainer: Brass Nut: Brass Gasket: Composite Fiber
	CSST X NPS	- 15M (1/2") x 1/2 - 20M (3/4") x 1/2 - 20M (3/4") x 3/4

	Appliance Stub Out	
	Material	Pipe: Schedule 40 Steel Plate: Steel
	Available Sizes	- 1/2 NPS - 3/4 NPS
	Meter Stub Outs	
	Material	Pipe: Schedule 40 Steel Plate: Steel
	Available Sizes	NPS x Pipe Length: -1/2 x 6" - 1/2 x 12" - 3/4 x 6" - 3/4 x 12" - 1 x 6" - 1 x 12" - 1 1/4 x 6" - 1 1/4 x 12"
	Fireplace Stub Out	
	Material	Pipe: Schedule 40 Steel Plate: Steel
	Available Sizes	NPS x Pipe Length: 1/2 x 7"
	Manifold Bracket	
	Material	Bracket: 16 Gauge Steel
	Available Sizes	N/A
	Right Angle Mounting Bracket	
	Material	Bracket: Steel
	Available Sizes	Fits CSST Adapter Nuts Sizes: - 3/8" and 1/2" - 3/4"
	Gas Outlet Box	
	Material	Box: Plastic Valve: Brass
	Available Sizes	15M (1/2") 20M (3/4")
	Quick Connects	
	Material	Box: Plastic Valve: Brass
	Available Sizes	Surface Mount Kit: - 1/2 NPS Valve Only: - 1/2 NPS
	Bonding Clamp	
	Material	Clamp: Bronze
	Available Sizes	1.WFBC: - Fits 3/8 through 1 ridged pipe sizes 2.WFBC: - Fits 1 1/4 through 2 Ridged pipe sizes. UL 467 Approved

3.0 SYSTEM CONFIGURATION AND SIZING

3.1 System Overview

3.1.1 Introduction

The following section will be used to assist you while you design and size your WARDFlex fuel gas piping system. At any point in which you require further assistance with this process you can visit our webpage (WWW.WARDMFG.COM) or contact Ward Manufacturing's Engineering Department.

WARDFlex® and WARDFlex®MAX are required to be tested, listed, and installed in accordance with the Standard For Fuel Gas Piping Systems Using Corrugated Stainless Steel Tubing, ANSI LC1. It is required by this standard to provide installation instructions which include proper sizing tables and methods of sizing.

3.1.2 System Design

In order to properly design a fuel gas piping system you must first recognize all the important criteria.

Requirements for a proper system design include:

- Verify your system meets all local codes. When local codes are in conflict with the manufactures guidelines the local codes must always take precedence.
- Determine the supply pressure coming from the meter by means of a gauge or a rating supplied by the gas company.
- Determine your total system demand for all appliances as well as the largest single load.
- Prepare a floor plan sketch with the load and length combinations for all appliances.
- Determine your allowable pressure drop.

IMPORTANT NOTE:

When choosing a pressure drop to size a WARDFlex system the minimum operating pressure of the appliance must be considered. Choosing a pressure drop that will reduce the supply pressure below the minimum operating pressure of the appliance will cause the appliance to perform poorly or not at all.

Example:

System Supply Pressure: 7 inches W.C.

Appliance minimum operating pressure: 5 inches W.C.









The use of a 3 inch W.C. pressure drop would result in a minimum inlet pressure at the appliance of 4 inches W.C. In this case an alternate pressure drop of 2 inches or less should be selected to meet the minimum operating pressure of the appliance.

3.2 SYSTEM CONFIGURATIONS

3.2.1 Introduction

There are multiple configurations in which you can install gas piping systems. The following sections will explain these different types of configurations. To the right is a key to accompany the figures used throughout the section:

KEY:

	BLACK PIPE
	WARDFLEX PIPE
	METER
	APPLIANCE SHUT OFF VALVE
	MANIFOLD
	REGULATOR
	TEE
	SERVICE SHUT OFF VALVE

3.2.2 SERIES SYSTEMS

A series system is the most commonly used system for rigid pipe systems utilizing low pressure. A typical series system contains a main run (header) which branches off with tees to the individual appliances. An example of a series system can be seen in figure 3.1.

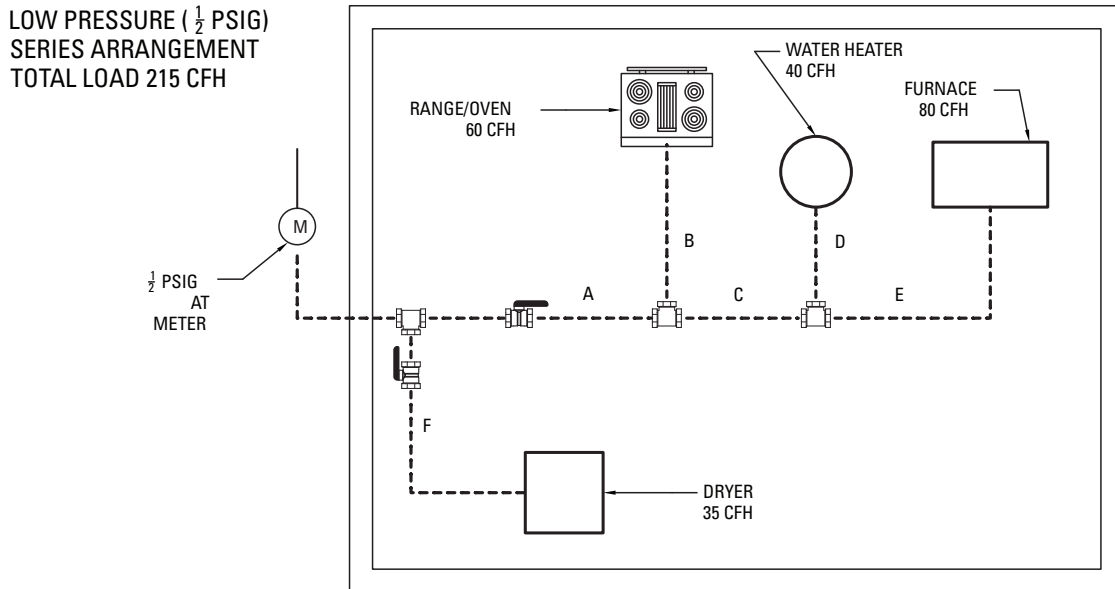

FIGURE 3.1

3.2.3 Parallel Systems

In a parallel system a main run from the meter supplies a central distribution manifold. Individual runs from the manifold supply the appliances. Typically it is best to position the manifold closest to the appliance requiring the greatest load. An example of a parallel system can be seen below in figure 3.2.

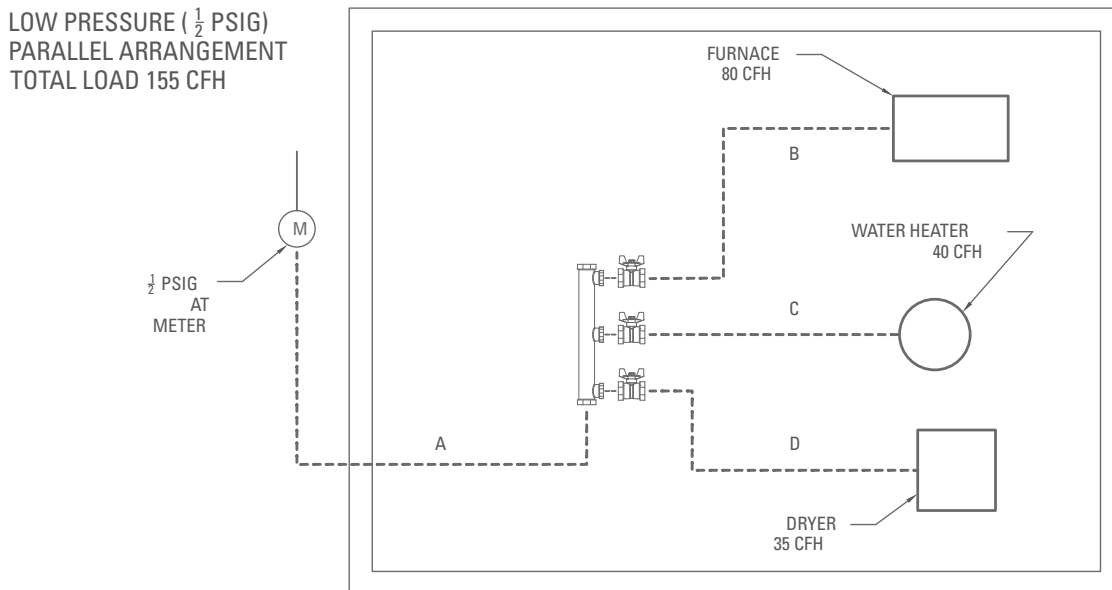

FIGURE 3.2

3.2.4 DUAL PRESSURE SYSTEMS

A dual pressure system utilizes two operating pressures downstream of the meter. The first pressure is set by the service regulator and is usually 2 PSI but can be higher or lower depending on local code. This is the high pressure side of the system. The second operating pressure also known as the low pressure side of the system is set with a pound-to-inches regulator. This pressure can be between 8 to 14 inches W.C. depending on local code, system design, and type of fuel gas. A dual pressure system is shown below in figure 3.3.

**HIGH PRESSURE (2 PSIG)
PARALLEL ARRANGEMENT
TOTAL LOAD 215 CFH**

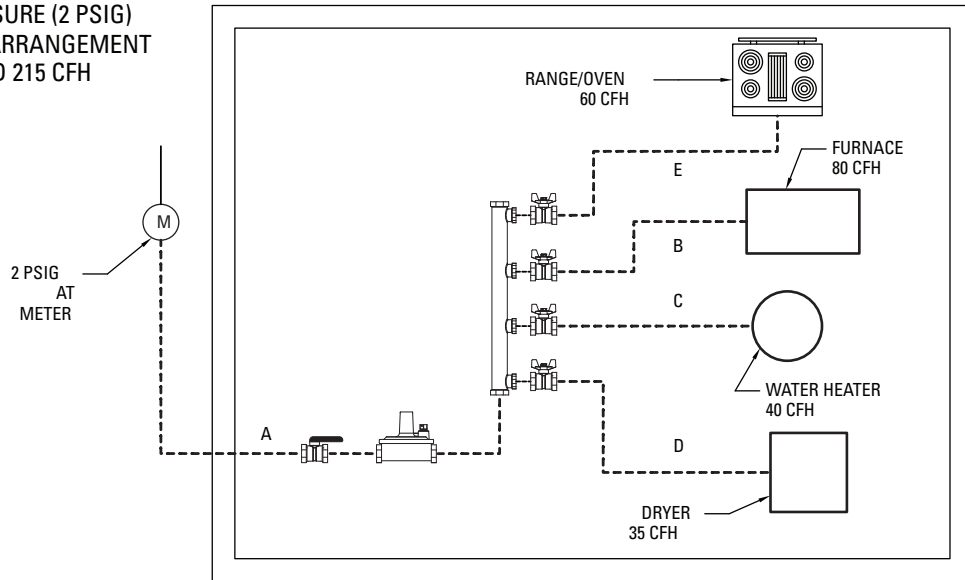

FIGURE 3.3

3.3 SYSTEM SIZING

3.3.1 INTRODUCTION

This section will provide you with sizing methods and examples. The following procedures should be closely followed when sizing the WARDFlex system to ensure it will operate properly. Section 7 of this Design and Installation Guide contains tables that will help you properly select tubing sizes. Care should be taken to ensure you are using the correct tables for your system requirements. For additional assistance with sizing contact Ward Manufacturing's Engineering Department.

3.3.2 LONGEST LENGTH METHOD

When using the longest length method to size a system you must use a table that fits your design criteria. For sizing each run of tubing you need to determine the total gas load for all appliances serviced by that section as well as the longest length that particular section delivers gas. The longest length must include the run from the meter to the furthest appliance. The longest length method can also be used for hybrid and dual pressure systems.

In the case of a dual pressure system you would size the run from the meter to the regulator separately from the rest of the system. The following examples demonstrate the use of the longest length method.

EXAMPLE 1: LOW PRESSURE PARALLEL SYSTEM

The following example demonstrates a typical single family house with 4 appliances with a centrally located manifold. The pressure at the meter is 14 inches W.C. (.5 PSIG) and the allowable pressure drop is 6.0 inches W.C. Table A-3 will be used for this example.

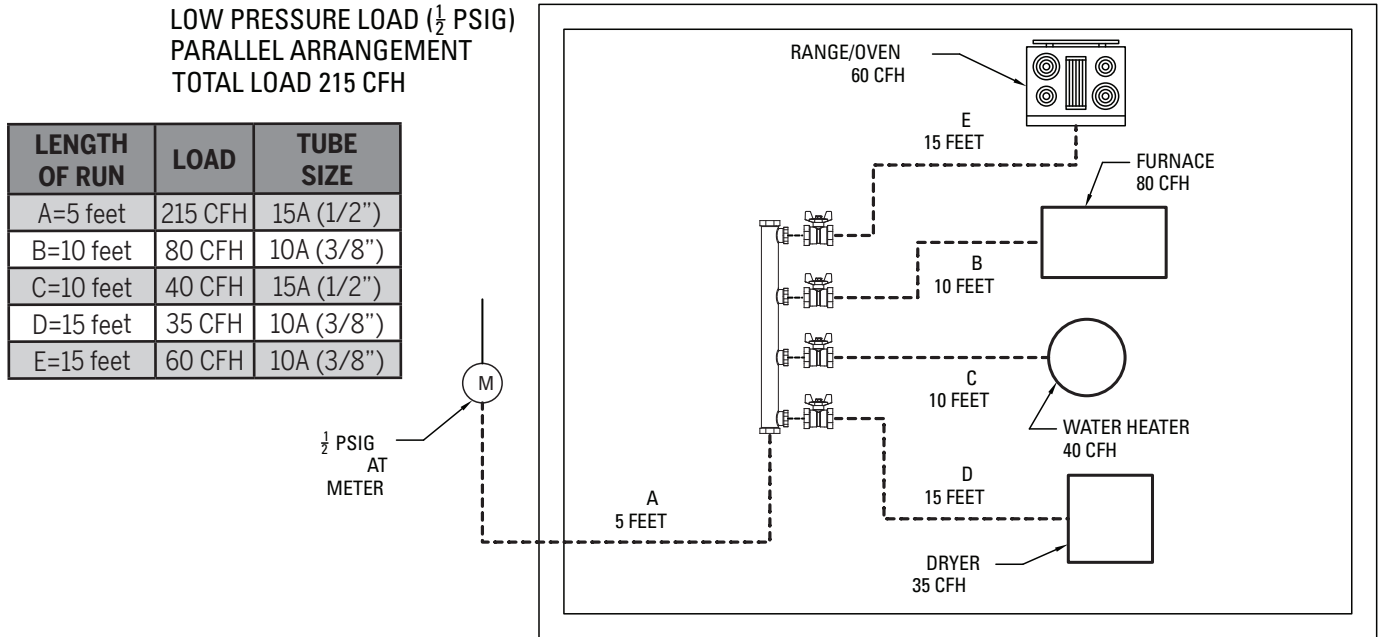

FIGURE 3.6

SIZING PROCEDURE:

1. Size Section "A"
 - Determine distance from meter to furthest appliance (range/oven 20 ft.)
 - Determine total load supplied by "A" (215 CFH).
 - Refer to Table A-3 for a length of 20 ft. and a load of 215 CFH.
 - Section "A" will be size 15A tubing.
2. Size Section "B"
 - Distance from meter to furnace is 15 ft.
 - Load is 80 CFH.
 - Table A-3 indicates size 10A tubing.
3. Size Section "C"
 - Distance from meter to water heater is 15 ft.
 - Load is 40 CFH.
 - Table A-3 indicates size 10A tubing is required.
4. Size Section "D"
 - Distance from the meter to the dryer is 20 ft.
 - Load is 35 CFH.
 - Table A-3 indicates size 10A tubing is required.
5. Size Section "E"
 - Distance from the meter to range/oven is 20 ft.
 - Load is 60 CFH.
 - Table A-3 indicates size 10A tubing is required.

EXAMPLE 2: LOW PRESSURE SERIES SYSTEM

This example demonstrates a low pressure series arrangement. The main run (header) uses Tees to branch off to the appliances. The dryer has a separate service line to prevent the use of large tubing sizes. The pressure at the meter is 14 inches W.C. (.5PSI) and the allowable pressure drop is 6 inches W.C. Table A-3 will be used.

LENGTH OF RUN	LOAD	TUBE SIZE
A=10 feet	180 CFH	15A (1/2")
B=15 feet	60 CFH	10A (3/8")
C=10 feet	120 CFH	15A (1/2")
D=5 feet	40 CFH	10A (3/8")
E=10 feet	80 CFH	10A (3/8")
F=10 feet	35 CFH	10A (3/8")

LOW PRESSURE (1/2 PSIG)
SERIES ARRANGEMENT
TOTAL LOAD 215 CFH

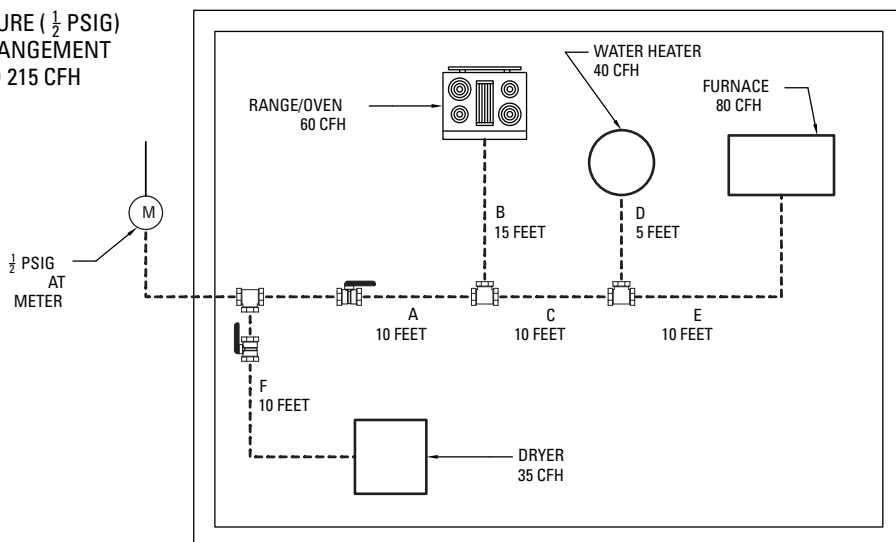

FIGURE 3.7

SIZING PROCEDURE:

- Size Section "A"
 - Distance from meter to furthest appliance (furnace) is 30 ft.
 - The load that "A" delivers is 180 CFH.
 - Table A-3 at 30 ft. indicates a flow of 192 CFH with size 15A tubing.
- Size Section "B"
 - Distance from meter to range/oven is 25 ft.
 - Load is 60 CFH.
 - Table A-3 indicates size 10A tubing.
- Size Section "C"
 - The longest run from the meter that includes section "C" is 30 ft. (meter to furnace).
 - The total load that "C" delivers is 120 CFH.
 - Table A-3 indicates size 15A tubing.
- Size Section "D"
 - Meter to water heater is 25 ft.
 - Load is 40 CFH.
 - Table A-3 indicates size 10A tubing.
- Size Section "E"
 - The longest run that includes section "E" from the meter to the furnace is 30 ft.
 - Load is 80 CFH.
 - Table A-3 indicates size 10A tubing is required.
- Size Section "F"
 - The longest run that includes section "F" from the meter to the dryer is 10 ft.
 - Load is 35 CFH.
 - Table A-3 indicates size 10A tubing is required.

Example 3: DUAL PRESSURE PARALLEL SYSTEM

This example shows the proper way to size a dual pressure system. The use of two operating pressures downstream of the meter require two sizing tables be used and each side of the system should be sized separately. Tables A-4 and A-6 will be used.

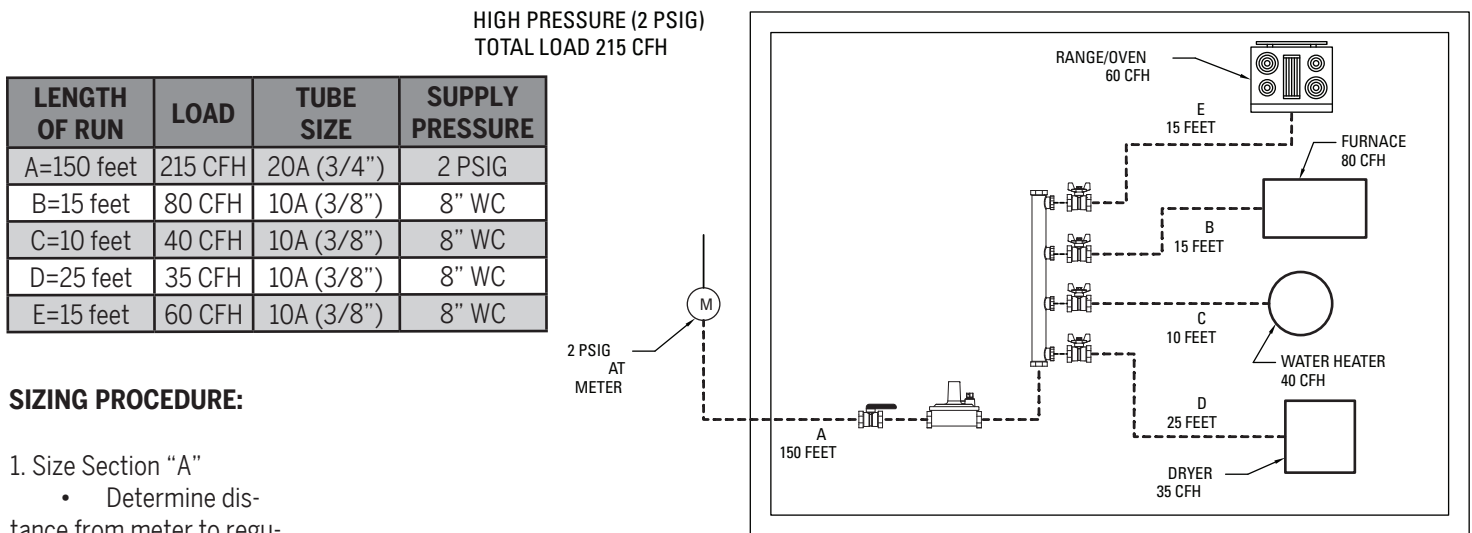

SIZING PROCEDURE:

1. Size Section "A"
 - Determine distance from meter to regulator (150 ft.).
 - Determine the load supply by "A" (215 CFH).
 - Refer to Table A-6 to determine the tubing size needed to deliver the maximum system capacity at 2 PSIG use 20A per table A-6.
2. Size Section "B"
 - Regulator to furnace is 15 ft.
 - Load is 80 CFH.
 - Table A-4 indicates size 10A tubing.
3. Size Section "C"
 - Regulator to water heater is 10 ft.
 - Load is 40 CFH.
 - Table A-6 indicates size 10A tubing.
4. Size Section "D"
 - Regulator to dryer is 25 ft.
 - Load is 35 CFH.
 - Table A-6 indicates size 10A tubing.
5. Size Section "E"
 - Regulator to range/oven is 15 ft.
 - Load is 60 CFH.
 - Table A-6 indicates size 10A tubing.

3.3.3 Equivalent Lengths Factor for Fittings and Valves

For additional pipe sizing information concerning equivalent lengths in feet of corrugated stainless steel tubing for fittings and valves refer to the "National Fuel Gas Code" ANSI Z223.1 NFPA 54. In Canada, refer to the applicable sections of the CAN/CGA B149 Installation Codes. Apply the following coefficients to the equivalent length in feet of 1/2 in. nominal schedule 40 straight pipe to convert to corrugated tubing.

TABLE A-36 EQUIVALENT LENGTHS FACTOR FOR FITTINGS AND VALVES
10A TUBING $L_2^1 = L_1^2 (0.08)N^3$
15A TUBING $L_2 = L_1 (0.4)N$
25A, 32A, 38A, 50A TUBING $L_2 = L_1 (6.0)N$
¹ L ₁ = LENGTH IN FEET OF 1/2 IN. SCHEDULE 40 (STANDARD WEIGHT) STRAIGHT PIPE.
² L ₂ = EQUIVALENT LENGTH IN FEET OF 10A/15, 15A/19, 20A/25, 25A/31, 32A/39, 38A/48 OR 50A/62 TUBING FOR FITTINGS AND VALVES.
³ N = NUMBER OF FITTINGS OR VALVES.

3.3.4 Summation Sizing Method

An alternate solution to the longest length method is the summation sizing method which adds the pressure drops through a particular section of tubing or black pipe. This can be an useful method when the supply pressure and/or pressure drop is not indicated in one of the sizing charts. This method for sizing is more accurate than the longest length method because you're doing actual calculations for load and length combinations rather than taking from a range of values in a chart. Summation Charts can be found at www.wardmfg.com.

The procedure for the summation sizing method is as follows:

1. Make a sketch containing the load and lengths for your system.
2. Find the desired flow in the left hand column
3. Now locate the desired tubing size in the top row of the table.
The point at which these two intersect is your pressure drop per foot of the selected tubing size.
4. Multiply this value by the length of this portion of the system and you have pressure drop for this section of tubing.
5. Repeat this procedure for any additional legs in the system.
6. Now add up the pressure drops to find the total system pressure drop.
7. If this value is greater than the allowable pressure drop for the system you must increase your tubing or pipe size.

4.0 INSTALLATION PRACTICES

4.1 GENERAL INSTALLATION PRACTICES

ATTENTION:

WARDFlex® SYSTEMS ARE ENGINEERED FUEL GAS PIPING SYSTEMS AND AS SUCH, THE TUBING AND FITTINGS ARE NOT INTERCHANGEABLE WITH OTHER CSST MANUFACTURER'S PRODUCTS. THE USE OF OTHER CSST PRODUCTS WITH ALL WARDFLEX SYSTEMS® IS PROHIBITED. CONNECTION BETWEEN TWO DIFFERENT MANUFACTURERS CSST PRODUCTS MAY BE ACCOMPLISHED USING MALLEABLE IRON PIPE FITTINGS WITH ASME B1.20.1 COMPLIANT THREADS.

- A. All System hardware should be stored in its original package in a clean dry location prior to installation. Care must be taken to ensure all WARDFlex® SYSTEMS are not damaged prior to installation.
- B. Tubing ends must be temporarily capped, plugged or taped prior to installation to prevent dirt or other foreign debris from entering the tubing.
- C. Tubing exposed to extreme low temperatures should be allowed to come up to room temperature prior to installation.
- D. Care must be taken to not kink, tangle, twist, stretch or apply excessive force to the tubing or fittings. WARDFlex® SYSTEMS are flexible piping system and can be bent during installation around obstructions. Avoid stressing the tubing with tight bends and repetitive bending. Refer to Table 4.1 for recommended bend radius for both WARDFlex® SYSTEMS
- E. When installing in, through or around sharp metal structures (i.e. metal studs, sheet metal, i-beams), rubber grommets or protective tubing should be used to prevent any direct contact which could subject the tubing to damage.

Table 4.1

TUBING SIZE	ABSOLUTE MINIMUM BEND RADIUS	RECOMMENDED INSTALLED BEND RADIUS INCHES
10A (3/8")	3/4"	3"
15A/15C (1/2")	3/4"	3"
20A/20C (3/4")	1"	3"
25A/25C (1")	1-1/4"	3"
32A/32C (1-1/4")	1-5/8"	4"
38A/38C (1-1/2")	4"	5"
50A/50C (2")	4-1/2"	6"

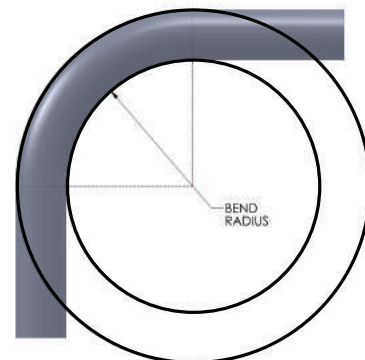

F. Tubing should be supported in a workman like manner with metallic pipe straps, bands, brackets, hangers or building structural components suitable for the size of piping support intervals are not to exceed those shown in Table 4.3. A proper support is one which is designed to be used as a pipe hanger, does not damage the tubing during installation, and provides full support of the tubing once installed. Plastic zip ties and/or cable ties are not to be used as the primary support for the CSST tubing.

ATTENTION:

WHEN SUPPORTING WARDFlex® YELLOW JACKETED CSST AVOID USING CONDUCTIVE METALLIC SYSTEMS SUCH AS, DUCTING, PIPING, VENTING, AND ELECTRICAL CABLES TO SUPPORT THE PIPING.

G. WARDFlex system components shall not be exposed to any acids, bases, salts or other caustic materials. Some chemical compounds have been identified that may aggressively corrode 304 stainless steel. Contact with these chemicals should be absolutely avoided. Any contact should immediately and thoroughly be washed off. The plastic covering is not affected by these compounds and will protect the tubing as long as it is undamaged. Should the plastic covering become damaged, wrapping 2 layers of WARDFlex® self fusing tape around the exposed area will help prevent from exposure to the caustic materials. See the list below of some chemicals to avoid.

CHEMICALS TO AVOID INCLUDE: BUT NOT LIMITED TO:

- Hydrochloric Acid (common name: muriatic or brick wash)
- Zinc Chloride and Ammonium Chloride (soldering flux, pool algacide)
- Calcium or Sodium Hypochlorite (bleach or pool chemicals)
- Copper Chloride (may be found in fungicides or wood preservatives)
- Ferric Chloride (swimming pool flocculent)
- Phosphoric Acid (scale removers)
- Sodium Chloride (salt water)
- Sulfuric Acid (battery acid)
- Leak detection with chloride-containing compounds found in some common soap (e.g., dishwashing soap) can corrode WARDFlex®. Avoid use of these compounds in connection with WARDFlex®.



Any leak detection solution coming in contact with the WARDFlex® System should have a sulfur and halogen content of less than 10 ppm of each (ASTM E515-05 section 7.4).



4.2 FITTING ASSEMBLY

4.2.1 WARDFlex® AND WARDFlex®MAX STEPSAVER FITTING

Step 1 - Cut the Tubing

Using a tubing cutter, cut the WARDFlex® or WARDFlex®MAX tubing to the desired length. Then using a utility knife remove the coating to expose a minimum of 4 corrugations. NOTE: The coating on the WARDFlex®MAX tubing shall be stripped back no more than 5 corrugations. Be sure not to score the tubing while removing the plastic coating.

Step 2 - Install the Nut and Retainer

Slide the nut over the tubing and place the retainer ring. Leave one corrugation exposed from the end of the retainer to the end of tubing. The small end of the retainer must point towards the cut end of the tubing.

Step 3 - Install the Body

Slide the nut over the retainer and thread it onto the body rotating only the nut.

Step 4 - Wrench Tighten

Using appropriate wrenches, tighten the nut until it fully contacts the body. Tightening torque should not exceed the maximum torque listed in Table 4.2 Do not use any thread sealant on the CSST Connection. Thread sealant should be used only for NPT threaded connections.

NOTE:

During tightening, rotate the Nut ONLY; The Body must not be rotated with respect to the tubing.



4.2.2 WARDFlex FITTING REASSEMBLY

A. The STEPSAVER fitting, with its patented dual seal technology which when installed correctly, will give you a quick reliable seal the first time every time should the need arise to disassemble a WARDFlex® System.

A STEPSAVER fitting may be reused if:

- The metal to metal and gasket seals show no signs of extensive physical damage.
- The threads on both the nut and body of fitting assembly show no signs of extensive physical damage.
- Both halves of the retainer are intact.

B. The WARDFlex 38M (1 1/2") and 50M (2") fittings are also allowed for reuse if:

- The gasket seals show no signs of extensive physical damage.
- If the gasket is damaged, replacements are available.
- The threads on both the nut and body of fitting assembly show no signs of extensive physical damage.
- Both halves of the retainer are intact.

C. As with any installation, a pressure test shall always be performed before placing the piping system into service. See section 6.1 for Pressure Testing and Inspection Procedure.

TUBING SIZE	WARDFlex MAXIMUM TIGHTENING TORQUE
10A (3/8")	50 ft-lb
15A (1/2")	50 ft-lb
20A (3/4")	120 ft-lb
25A (1")	160 ft-lb
32A (1-1/4")	200 ft-lb
38A (1-1/2")	200 ft-lb
50A (2")	200 ft-lb

Table 4.2

4.2.3 WARDFlex Underground CSST

WARDFlex Underground may be buried in the Earth without the need of additional sleeving. WARDFlex Underground CSST is to be installed with the fittings designed to be used with the tubing. These fittings utilize an o-ring to seal the end of the fitting with the jacket on the CSST. The burial depth for WARDFlex Underground must conform to local codes but shall not be less than 12 inches. When transitioning WARDFlex Underground CSST to above ground a gradual bend should be used. The minimum bend radius for both sizes, 1/2" and 3/4", is 6 inches. When WARDFlex Underground is routed through or embedded in concrete it must be routed through a non-metallic conduit, such as PVC pipe. The conduit used must have an ID that is at least 1/2" larger than the OD of the CSST.

WARDFlex Underground fittings are supplied with a 1/8" vent port. In the event that local code requires the system to be vented, the vent line shall be connected to this port. Vent lines that are routed to the outside of a structure must be installed to prevent the entrance of moisture, dirt, debris, and insects. If venting is not required, the 1/8" plug that is supplied with the fitting can be used to seal the vent port.

Step 1 – Stripping Coating

Measure and cut coating back 2 inches. Cut the coating half way through using a tubing cutter, cut the rest of the way through the coating using a utility knife. Take care not to score the CSST while cutting the coating.

Step 2 – Cut Tubing to Final Length

Cut the tubing with a tubing cutter to leave 7 corrugations exposed

Step 3 – Assemble the Fitting

ATTENTION: Ensure that the o-ring is properly seated in the groove in the back of the nut and there is an o-ring installed on the fitting body before assembly.

Step 3.1 – Install the Nut and Retainer

Apply a silicone lubricant to the o-ring installed in the nut. Slide the nut over the tubing and place the retainer ring on the tubing. Leave one corrugation exposed from the end of the retainer to the end of the tubing. The small end of the retainer must point towards the cut end of the tubing as seen in Figure 2.

Step 3.2 – Install the Body

Slide the nut over the retainer and thread it onto the body rotating only the nut. Figure 3.

Step 3.3 – Wrench Tighten

Using appropriate wrenches, tighten the nut until it fully contacts the body. Tightening torque should not exceed the maximum torque listed in Table 4.2. Do not use any thread sealant on the CSST Connection. Thread sealant should be used only for NPT threaded connections.

Step 4 – Vent/Plug Installation

If venting from the 1/8" threaded port on the nut is required install the vent in accordance with local code. If no vent is installed, remove the 1/8" plug apply an approved pipe thread sealant and reinstall the plug.

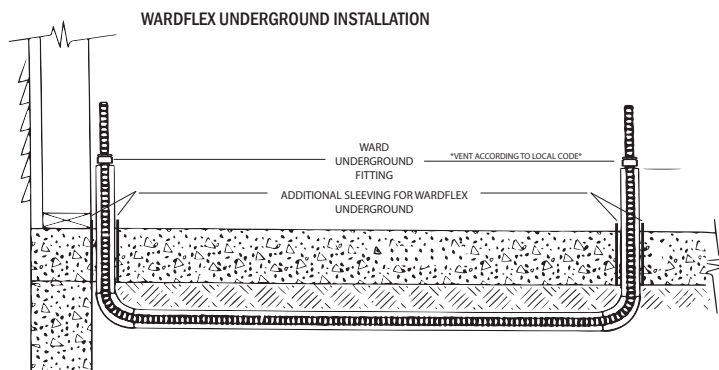
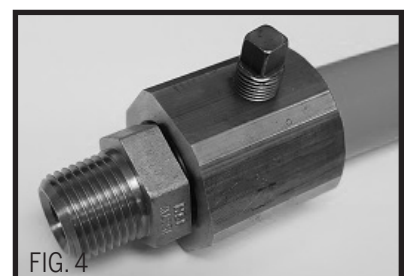
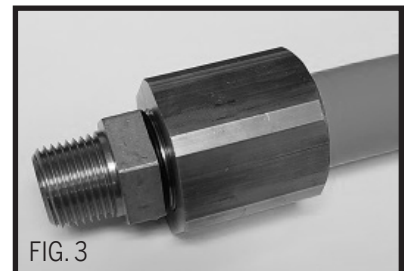
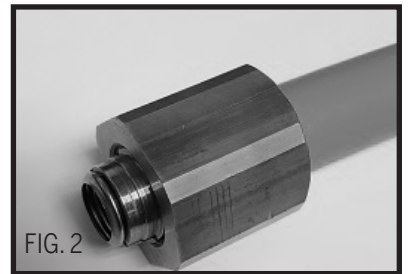
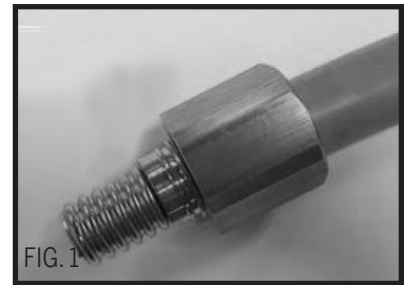

FIG. 5

4.3 Tubing Routing

4.3.1 VERTICAL RUNS

Vertical runs inside hollow wall cavities are the preferred location for installation of vertical sections.

To avoid damage, tubing should be free to move within the wall cavity without immediate supports between floors but must be supported at the point of penetration between floors. Vertical run support spacing is not to exceed 10 feet, requiring hangers only where the height of each floor is greater than 10 feet. The run must conform to Section 4.4 Protection if it is installed in a location that it will be concealed.

4.3.2 HORIZONTAL RUNS

Areas beneath, alongside, or through floor and ceiling joists or other structural members are typical installation locations for both residential and commercial applications. Structural members may be considered supports for horizontal tubing if they meet the requirements as specified in Table 4.3. The run must conform to Section 4.4 Protection if it is installed in a location that it will be concealed.

ATTENTION:

Care should be taken when installing WARDFlex® Yellow jacketed CSST, to maintain as much separation as reasonably possible from other electrically conductive systems in the building.

TUBING SIZE	MINIMUM SUPPORT INTERVAL
10A (3/8")	4 feet.
15A/15C (1/2")	6 feet.
20A/20C (3/4")	8 feet USA 6 Feet Canada
25A/25C (1")	8 feet USA 6 Feet Canada
32A/32C (1-1/4")	8 feet USA 6 Feet Canada
38A/38C (1-1/2")	8 feet USA 6 Feet Canada
50A/50C (2")	8 feet USA 6 Feet Canada

TABLE 4.3

4.3.3 Clearance Holes and Notching

Clearance holes for routing WARDFlex®/ WARDFlex®MAX CSST shall have a diameter at least 1/2" greater than the outside diameter of the tubing. The minimum hole diameters for each tubing size are listed in Table 4.4. Table 4.5 identifies some basic guidelines if drilling and/or notching is required of any structural member. However you should always check local code requirements before proceeding.

- A. Holes drilled in vertical members of the wall framing should not exceed 1/4 the width of the member.
- B. Holes drilled in plates and other horizontal frame members should not exceed 1/2 the width of the member.
- C. Where a hole is to be drilled in a joist, the outside edge of the hole should be located not less than 3 in. away from the floor or ceiling.
- D. Notching is not preferred practice, however, when notching, the notched depth must be a minimum of one tubing diameter with the maximum notch being determined by local code.
- E. See Table 4.5 for typical maximum hole sizes in structural members.

TUBING SIZE	10A (3/8")	15A/15C (1/2")	20A/20C (3/4")	25A/25C (1")	32A/32C (1-1/4")	38A/38C (1-1/2")	50A/50C (2")
MINIMUM CLEARANCE HOLE DIAMETER	1-1/8"	1-1/4"	1-1/2"	1-3/4"	2-1/4"	2-5/8"	3-1/4"

TABLE 4.4

TABLE 4.5	A	B	C	D	E	F
DESCRIPTION	2"X4" STUD LOAD BEARING WALL	2"X4" STUD NON-LOAD BEARING WALL	2"X4" SOLE PLATE	2"X4" TOP PLATE	2"X6" FLOOR JOIST	2"X8" FLOOR JOIST
MAX. HOLE SIZE	1.375"	2.125"	2"	1.75"	1.75"	2.420"
Maximum WARDFLEX Tubing Size	20A/20C (1/2")	25A/25C (1")	25A/25C (1")	25A/25C (1")	25A/25C (1")	32A/32C (1-1/4")

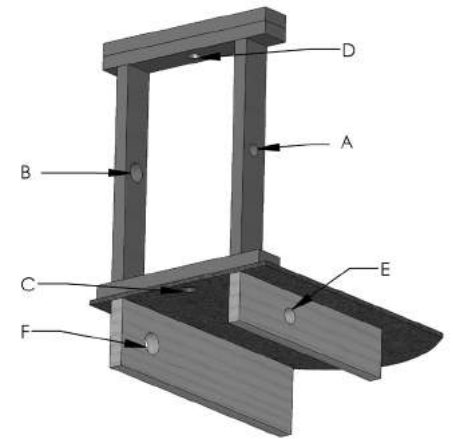

4.3.4 Concealed Locations for Fittings

WARDFlex mechanical fittings have been tested and listed per the requirements of ANSI LC-1 / CSA 6.26. This specification provides test requirements which certify fittings for concealed locations and connections where accessibility is not possible. When the use of a concealed fitting is required always reference the National Fuel Gas Code NFPA 54 or CSA B149 or other relevant local code. These guidelines address some of the known situations which may require the use of concealed fittings. This guide cannot address all applications of concealed fittings but instead provides typical instructions to demonstrate the principles which apply to fittings listed for installation in concealed locations.

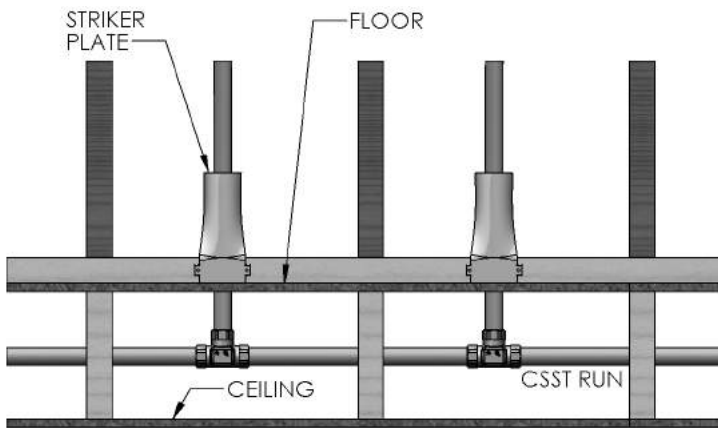

Figure 4.3 Multiple gas outlets connected to the same run of WARDFlex®/ WARDFlex®MAX. In this situation a tee-type fitting can be used and installed in a concealed location.

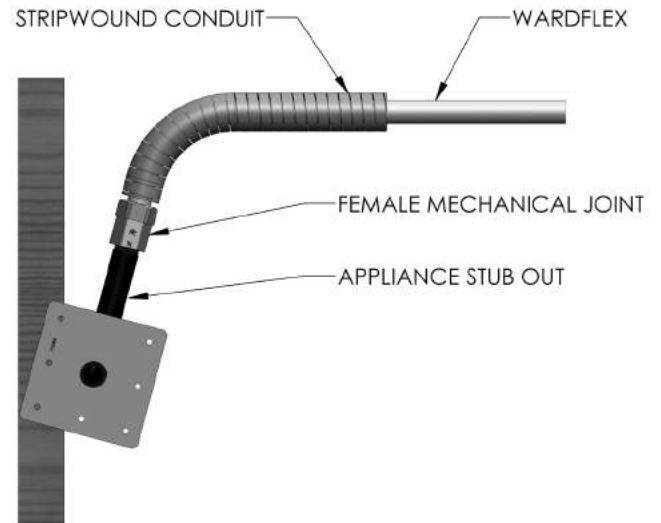

Figure 4.4 Appliance stub out with a WARDFlex®/ WARDFlex®MAX female mechanical fitting which can be installed in a concealed location. For this type of arrangement refer to section 4.4 on for protection details.

Installation in or through chimneys, clothes chutes, gas vents, dumbwaiters, and elevator shafts are all prohibited locations for

- A. WARDFlex fittings and tubing.
- B. Manifold stations for dual pressure systems, which include the multiport manifold, shutoff valves, and/or pressure regulators, shall not be installed in concealed locations regardless of the qualifications of the tubing fittings.
- C. Fittings installed inside accessible enclosure boxes, for such items as quick connect gas outlets or fire place shut off valves, are exempted from these guidelines.

4.3.5 MODIFICATION TO EXISTING SYSTEM

- A. New Ceilings in Unfinished Rooms/Basements - CSST fittings originally installed in accessible ceiling locations can be concealed in the event a ceiling is installed at a later date.
- B. Extension to Existing Tubing Run - Concealed CSST can be modified to permit an extension to another appliance location provided there is sufficient capacity to supply both applications at the same time. If an accessible location for the modification is not available, the existing tubing run can be modified with a tee fitting, resulting in a concealed fitting.
- C. When any modification to an existing CSST installation leads to concealed tubing, protection devices may be required. Refer to Section 4.4 for details on protection.

4.3.6 OUTDOOR INSTALLATIONS

Per ANSI LC-1/CSA 6.26 WARDFlex CSST products are approved for installation where exposure to outdoor environments can occur. The following guidelines shall be followed when installing WARDFlex outdoors to protect tubing and fittings from the effects of weather.

- A. The covering shall remain intact as much as practical for the given installation. Any portion of exposed stainless steel shall be wrapped with tape (e.g. PVC, Self Fusing Silicone) or sleeved (e.g. PVC, Polyolefin) to prevent corrosive attack by acid wash or other caustic compounds that may be present. If contact with caustic compounds should occur ensure that all traces are immediately removed to prevent premature corrosion failure.
- B. WARDFlex mechanical joint fittings shall be protected from the effects of weather when used outdoors. After the connection is made to outdoor equipment the fitting assembly shall be wrapped with tape (e.g. PVC, Self Fusing Silicone) or by applying shrink sleeves (e.g. PVC, Polyolefin) around the entire assembly.
- C. When installed outdoors between grade and six feet above WARDFlex must be protected inside non-metallic conduit or installed in a location where it will not be subjected to mechanical damage.
- D. When installed in crawl spaces or underneath mobile homes, WARDFlex shall be installed in accordance with these installation instructions.

4.3.7 FIRE RATED CONSTRUCTION

- A. WARDFlex have been reviewed for installation through UL Classified fire rated construction and is listed for use in a number of UL Through Penetration Firestop System Listings. See table 4.6 for a complete listing. System numbers are subject to change and deletion be sure to verify systems in the latest revision of UL Fire Resistance. In the event there is a conflict between this guide and UL, UL takes precedence.

TYPICAL INSTALLATIONS

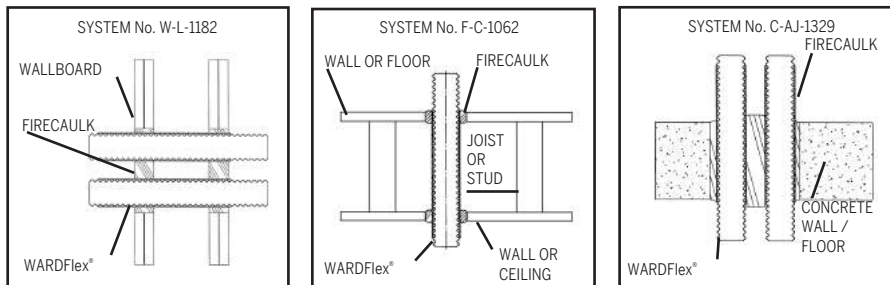

R18357 WARDFlex® UL Through Penetrating Firestop Listings

SYSTEM NUMBER	RATING HOUR		FIRECAULK PRODUCT	MAX SIZE	MAX QTY
	F	T			
C-AJ-1217	3 & 4	0	4.5	2	1
C-AJ-1225	2	0	1	2	1
C-AJ-1240	2 & 3	0	4.5,6	2	1
C-AJ-1327	3	2 & 3	2	1-1/4	1
C-AJ-1328	3	2 & 3	3	1-1/4	1
C-AJ-1329	3	2	2	1-1/4	3
C-AJ-1330	3	2	3	1-1/4	3
C-AJ-1346	2	0	9	1	1
C-AJ-1353	3	0	4	2	1
C-AJ-1354	2	0	4	2	1 OR MORE
C-AJ-1427	2	0	1.7,10	1	1
C-AJ-1428	2	0	1.7,10	1	1 OR MORE
C-AJ-1429	2	0	1.7,10	1	1 OR MORE
C-AJ-1513	2	0	9	2	1 OR MORE
C-AJ-1551	2	0	1.7,10.	1	1
C-AJ-1553	1 & 2	0	12	1	3
C-AJ-1556	2	0	1,10,13,14	1	1 OR MORE
C-AJ-1584	3	1	2,3,11,16,19	1-1/4	1 OR MORE
C-AJ-1600	3 & 4	0	15	2	1
C-AJ-1655	3	2	20	1-1/4	3
C-AJ-1658	3	1	20	1-1/4	1 OR MORE
F-C-1029	1 & 2	1	1	2	1
F-C-1061	1/4 & 1	1/4 & 1	2	1-1/4	1
F-C-1062	1/4 & 1	1/4 & 1	3	1-1/4	1
F-C-1074	1 & 2	1/4, 1/2 & 1	WF300 FIRESTOP CAULK	2	1
F-C-1075	1 & 2	1/4, 1/2 & 1	WF300 FIRESTOP CAULK	1	1 OR MORE
F-C-1094	1	1/4	1.7,10	1	1
F-C-1095	1	3/4	1.7,10	1	1 OR MORE
F-E-1002	1	1	4	2	1
F-E-1003	1	1	4	1	1 OR MORE
F-E-1009	1	1/4	1.7,10	1	1
F-E-1010	1	3/4	1.7,10	1	1
W-J-1079	2	2	2	1-1/4	1
W-J-1080	2	2	3	1-1/4	1
W-J-1081	2	2	2	1-1/4	3
W-J-1082	2	2	3	1-1/4	3
W-J-1098	2	1	4	1-1/4	1
W-J-1099	2	1	4	2	1
W-J-1101	2	1	4	2	1 OR MORE
W-J-1122	2	1/4	1.7,10	1	1 OR MORE
W-J-1127	2	1/4	1.7,10	1	1
W-J-1206	1 & 2	3/4 & 1 1/2	2,3,11,16,19	1-1/4	1 OR MORE
W-L-1001	VARIABLES	VARIABLES	1,10	1	1
W-L-1096	2	0	1	2	1
W-L-1179	1 & 2	1 & 2	2	1-1/4	1
W-L-1180	1 & 2	1 & 2	3	1-1/4	1
W-L-1181	1 & 2	1 & 2	2	1-1/4	3
W-L-1182	1 & 2	1 & 2	3	1-1/4	3
W-L-1199	1 & 2	1 & 2	2	1-1/4	1
W-L-1200	1 & 2	1 & 2	3	1-1/4	1
W-L-1222	1 & 2	1/4, 3/4 & 1	4	1-1/4	1
W-L-1223	1 & 2	1	4	2	1
W-L-1224	1 & 2	1	4	2	1 OR MORE
W-L-1243	1 & 2	0	9	1	1
W-L-1287	1 & 2	0 & 1/4	1.7,10	1	1 OR MORE
W-L-1296	1 & 2	0 & 1/4	1.7,10	1	1
W-L-1407	1 & 2	0	12	1	3
W-L-1427	1 & 2	3/4 & 1 1/2	2,3,11,16,19	1-1/4	1 OR MORE
W-L-1429	1 & 2	3/4 & 1 1/2	8	1-1/4	1 OR MORE
W-L-8071	1 & 2	0	9	2	1 OR MORE
W-L-1516	1 & 2	1 & 2	20	1-1/4	3

System No. explanations: First alpha: F=floor is being penetrated, W=wall, C=walls or floors, E=Floor-ceiling assemblies consisting of concrete with membran protection Second alpha: A=concrete floors with a minimum thickness less than or equal to 5 inches, C= framed floors, J=concrete or masonry walls with a minimum thickness less than or equal to 5 inches, L= framed walls. Rating hours: F= flame passage criteria, T= temperature rise of 325° F. Firecaulk Products: 1 3M COMPANY: CP-25-WB+, 2 Rectorseal: Metacaulk 1000, 3 Rectorseal: Biostop 500+ caulk, 4 Specified Technology: SpecSeal LCI sealant, 5 Specified Technology: SpecSeal 100, 101, 102, 105, 120 or 129, 6 Specified Technology: FS-One Sealant or FS-ONE MAX Intumescent Sealant 7 3M COMPANY: IC 15WB, 8 EGS NELSON FIRESTOP: LBS3+, FS-One Sealant or FS-ONE MAX Intumescent Sealant 11 Rectorseal: Biostop 350i 12 NUCO INC: Self Seal GG-266 13 3M COMPANY: FB-1000 NS 14 3M COMPANY: FB-1003SL IC 15WB+ 15 Hercules Chemical: Hercules Plumbers Firestop Sealant 16 Rectorseal: Metacaulk 350i 17 HILTI INC: CP 606 18 NUCO CO Self Seal GG-200 19 Rectorseal FlameSafe FS900+ or FS1900: 20 FISCHERWERKE GMBH & CO KG Fischer UFS 310. Consult UL Fire Resistance Directory-Volume 2 for specific construction details or contact WARD MANUFACTURING.

4.4 PROTECTION

4.4.1 Introduction

WARDFlex tubing shall be protected from physical damage caused by screws, nails, drill bits, etc. The tubing is most susceptible to puncture at all points of support. The best practice is to install the tubing in those areas where the likelihood of physical damage is minimized and no protection is needed; for example:

- A. Where tubing is supported at least 3 inches from any outside edge of a stud, joist, etc. or wall surface.
- B. Where any unsupported tubing can be displaced in the direction of potential penetration at least 3 inches.
- C. Where tubing is supported under the joist in basements or crawl spaces and is not concealed by wall board or ceilings.

When WARDFlex is installed in locations where the potential of physical damage exists, hardened steel striker plates must be used. Striker plates other than those provided for use with WARDFlex are prohibited. The tubing may also be routed inside strip wound conduit or schedule 40 pipe when protection is required.

In areas where penetration through studs, joists, plates and other similar structural members occur striker protection is required when all of the following criteria apply:

1. When the piping system is installed in a concealed location and is not viewable.
2. When the piping system is installed in a location that does not allow free movement to avoid puncture threats.
3. When the piping system is installed within 3 inches of possible points of penetration.

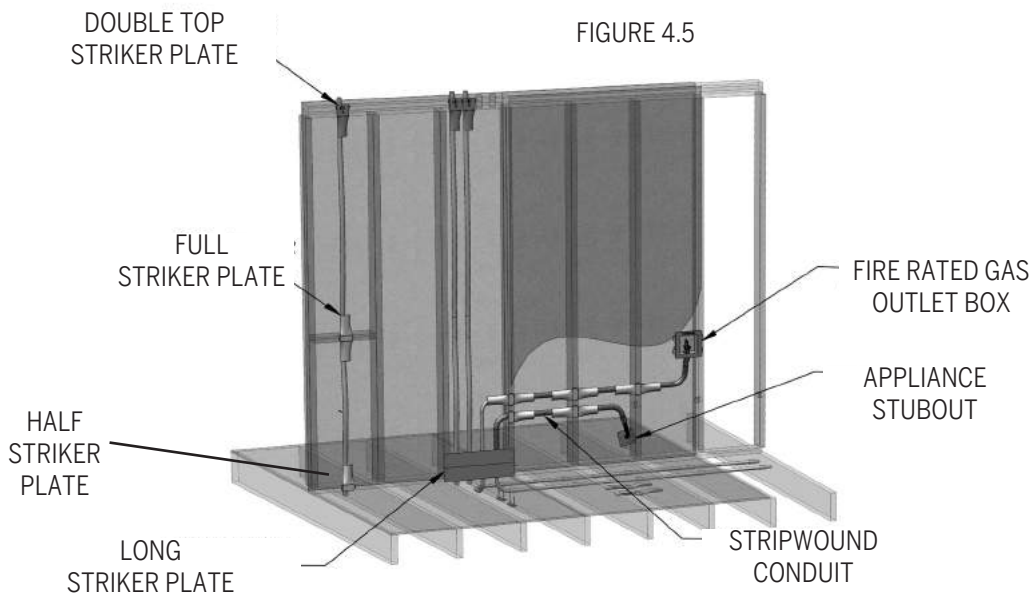

4.4.2 STRIKER PLATES

Striker plates are used to prevent tubing damage in areas where potential penetration threats exist through studs, joists, plates, and other similar structural members. Only striker plates supplied by Ward Manufacturing are permitted for use with WARDFlex. For installations where all three above criteria apply the following striker plate protection must be applied.

- A. At concealed support points and points of penetration less than 2 inches from any edge of a stud, joist, plate, etc. shielding is required at the area of support and extending 5 inches in one or both directions (if appropriate).
- B. At concealed support points and points of penetration within 2 to 3 inches from any stud, joist, plate, etc., listed quarter striker plates are required at the area of support. Figure 4.7 and Figure 4.8 show proper means of protection for this type of installation.

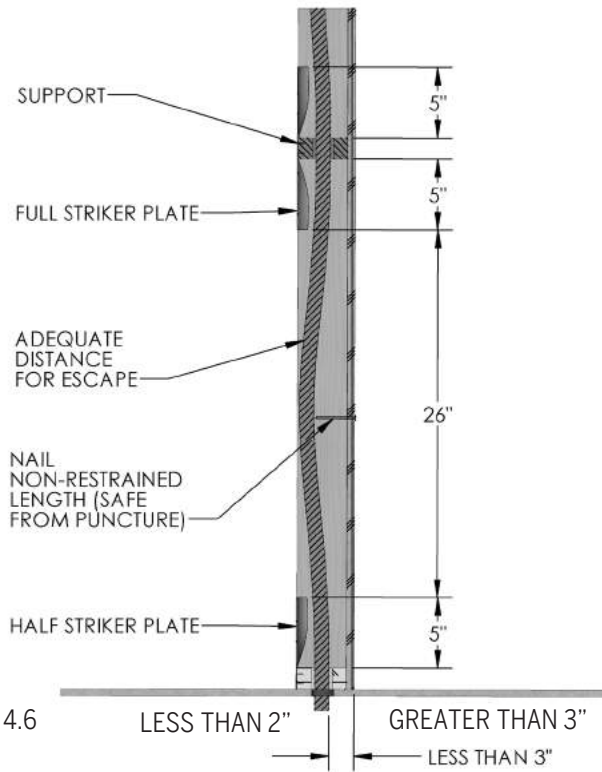

FIGURE 4.6

Figure 4.6 Typical locations where striker plates are required. Striker plates are installed at both horizontal penetrations unrestrained vertical runs of 26 inches or greater require no additional protection.

STRIPWOUND METAL CONDUIT

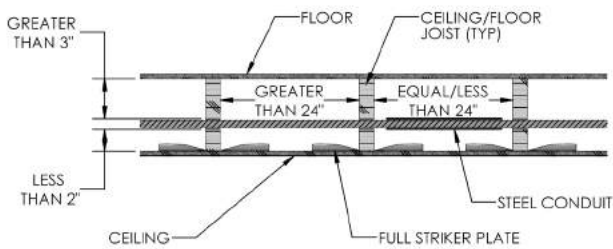

FIGURE 4.7

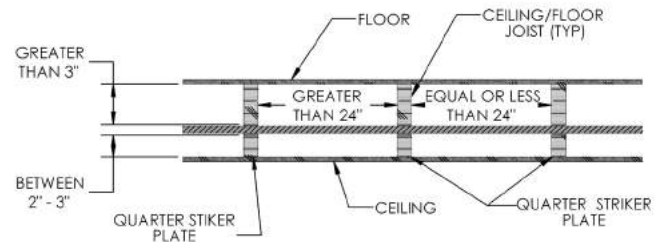

FIGURE 4.8

- C. Tubing routed horizontally through structural members shall be protected from puncture threats with the appropriate shielding material. At penetration joints, listed striker plates of the appropriate size shall be utilized. Tubing between constraints that are less than 24 inches apart and meeting the criteria requiring full striker plates, shall be additionally protected by stripwound metal conduit, or schedule 40 pipe.
- D. CSST greater than 1" nominal diameter installed within a concealed hollow wall cavity of 2" x 4" construction shall be protected along the entire concealed run length with stripwound metal conduit, or schedule 40 pipe.
- E. Should an unfinished ceiling (i.e. basement) be covered at a later date, the quarter striker plates, shown in figure 4.9 and 4.10, should be replaced with appropriate protection devices that provide adequate protection for potential penetration threats.
- F. Although figures 4.9 and 4.10 are acceptable, installation method 4.11 is preferred.

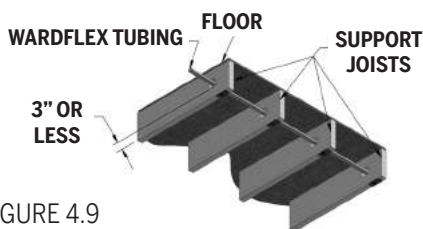

FIGURE 4.9

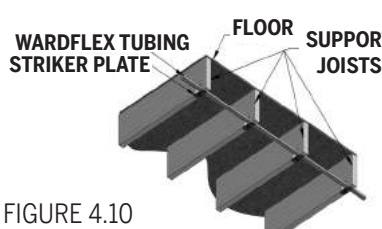

FIGURE 4.10

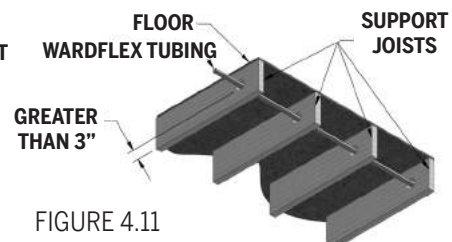

FIGURE 4.11

4.4.3 STRIPWOUND METAL CONDUIT

A. At termination points not covered by ANSI specifications, standard stripwound metal conduit shall be installed as additional protection. Stripwound conduit shall not be used as a substitute for striker plates where tubing passes through structural members.

B. Stripwound conduit shall also be used to shield tubing from puncture threats when WARDFlex is installed in a concealed location where it cannot be displaced a minimum 3" from a potential puncture threat or the distance between supports is less than 24 inches. See Figure 4.12.

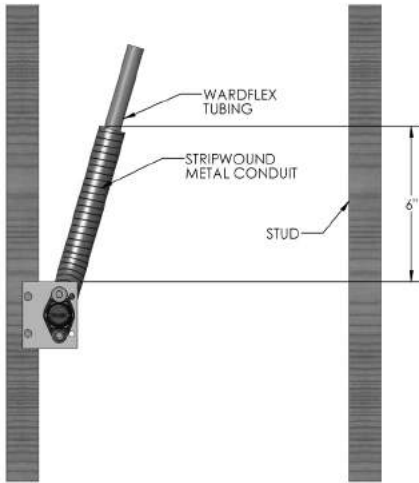

FIGURE 4.12

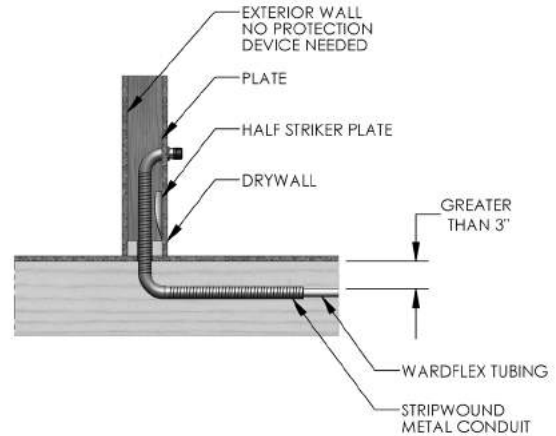

FIGURE 4.13

Figure 4.13 Termination fitting for an appliance connection with stripwound conduit providing extra protection inside the wall and floor cavities.

4.4.4 INSTALLATION IN INSULATED WALLS

Rigid installations present significant puncture threats for WARDFlex®/ WARDFlex®MAX installations in concealed spaces. In concealed spaces, e.g. wall cavities, rigid insulation will prevent CSST from being displaced. WARDFlex shall not be installed in a wall cavity with foam insulation without additional protection as described below.

- A. Tubing shall be routed through an approved conduit in walls where “foamed in” insulation is to be used i.e. rigid steel pipe or conduit. Approved conduit shall be secured according to local building practice.
- B. Protection methods such as pipe, conduit and strip wound hose, supply protection and give the tubing space in which to move. On exterior walls the tubing may be fastened to the sheathing with cable clamps or secured with sticks/wires sprung between studs to center tubing between interior and exterior surfaces.
- C. When tubing is installed inside walls with batt insulation the tubing shall be routed between the face (craft paper/vapor barrier) and the wall surface. If installed in a concealed location where it cannot be displaced a minimum 3" from a potential puncture threat the run shall be protected with stripwound conduit.
- D. CSST tubing does not need additional protection where it is more than three inches from any puncture threats although consideration must be given to the chance that it may migrate toward penetration threats as the insulation is applied and during curing.

4.5 METER CONNECTION

4.5.1 UNSUPPORTED METERS

- A. Meters which depend on the service and house piping for support shall not be directly connected to the flexible gas piping.
- B. The use of an outdoor termination fitting mounted to the exterior of the structure, meter stubout or other rigidly mounted termination fitting are acceptable transitional methods.

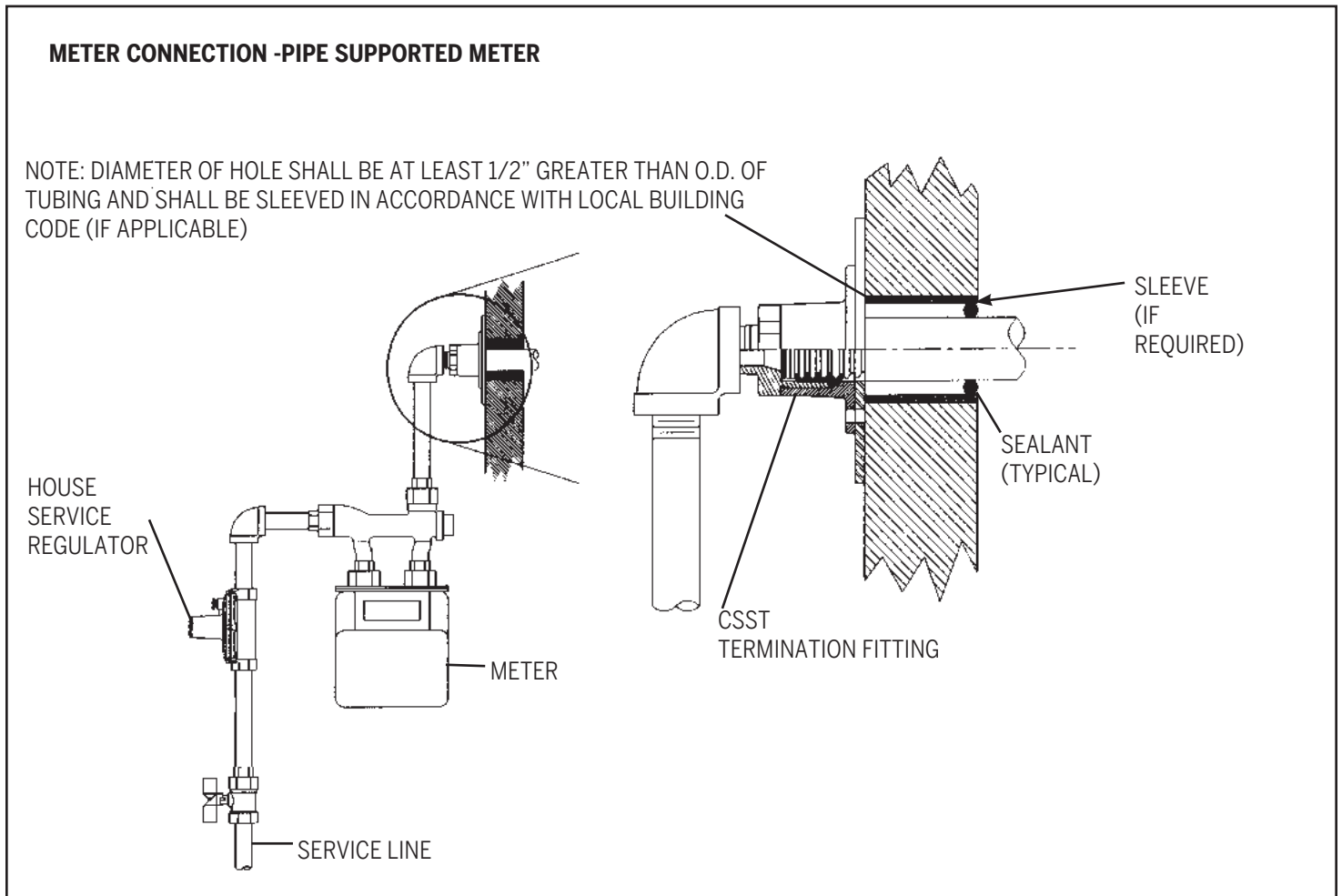
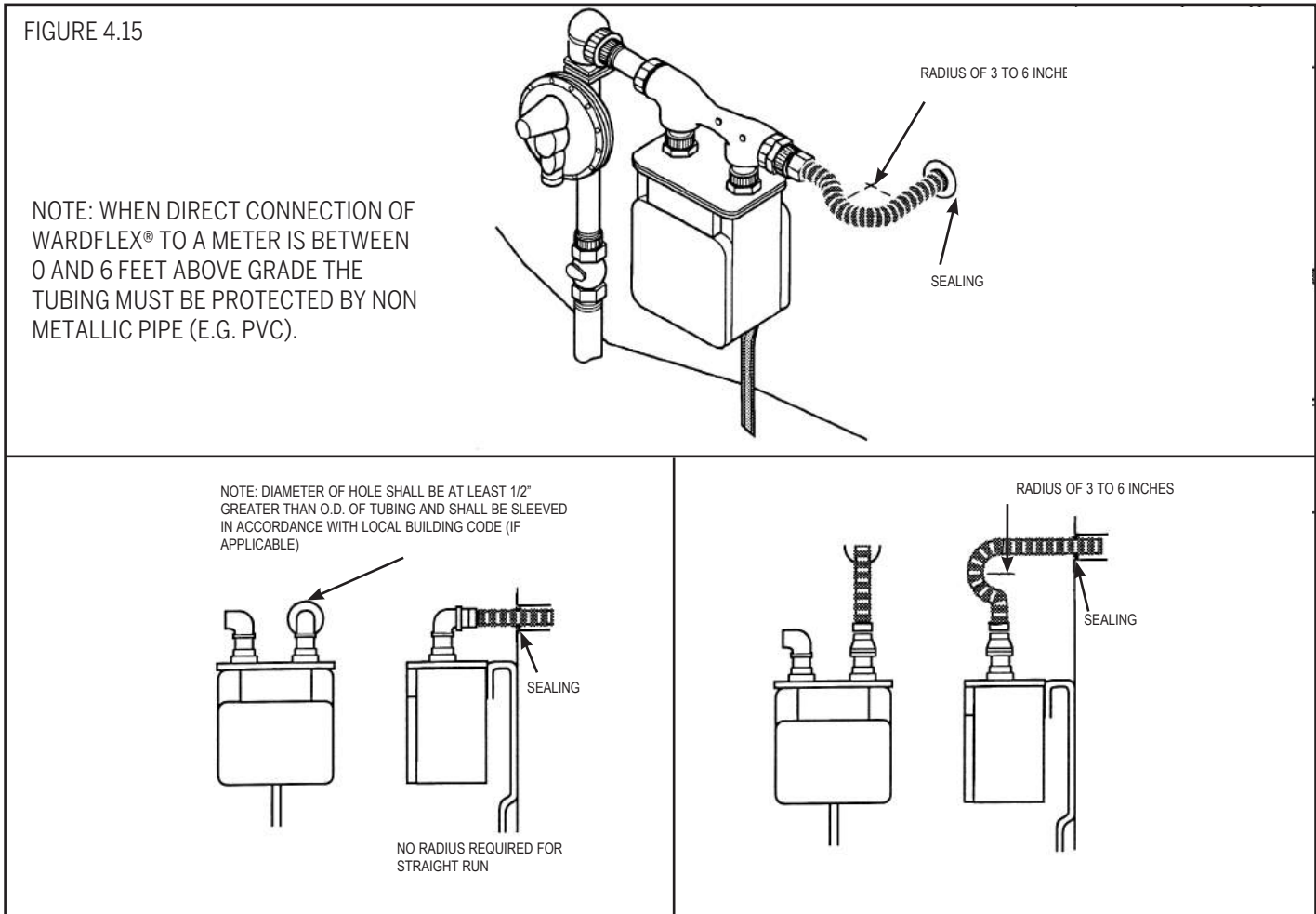

FIGURE 4.14

4.5.2 SELF SUPPORTED METER

- A. Meters which are independently supported by a bracket may be directly connected to WARDFlex®/WARDFlex®MAX.
- B. If practical a 3 to 6 in. loop of tubing should be included to compensate for meter movement and differential setting.

NOTE: WARD MANUFACTURING DOES NOT REQUIRE MECHANICAL PROTECTION FOR OUTDOOR METER CONNECTION MORE THAN 6 FT. ABOVE GRADE HOWEVER, LOCAL CODES MUST BE CONSIDERED. CHECK WITH YOUR LOCAL CODE AUTHORITY.



4.6 APPLIANCE CONNECTIONS

4.6.1 Moveable Appliances

IMPORTANT! WARDFlex ARE NOT RATED AS FLEXIBLE APPLIANCE CONNECTORS AND MUST NOT BE DIRECTLY CONNECTED TO MOVABLE APPLIANCES.



- A. When using WARDFlex® or WARDFlex®MAX with moveable appliances such as ranges or dryers, the tubing must be rigidly terminated before the appliance. Appliance stub outs, termination fittings or transitioning to rigid black pipe are acceptable means to terminate CSST prior to the appliance.
- B. Final connection from CSST termination point to a movable appliance shall be made with a flexible appliance connector or another approved connection device.



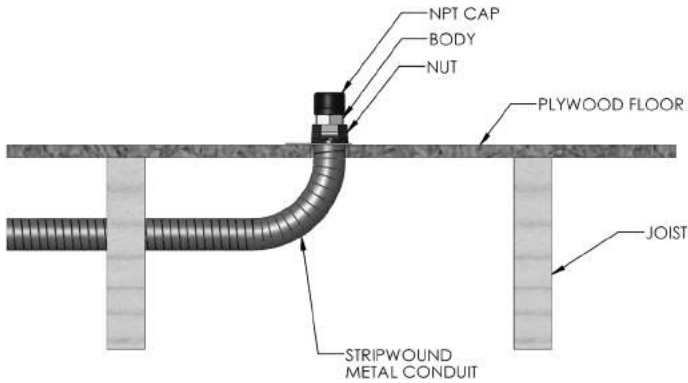

FIGURE 4.16

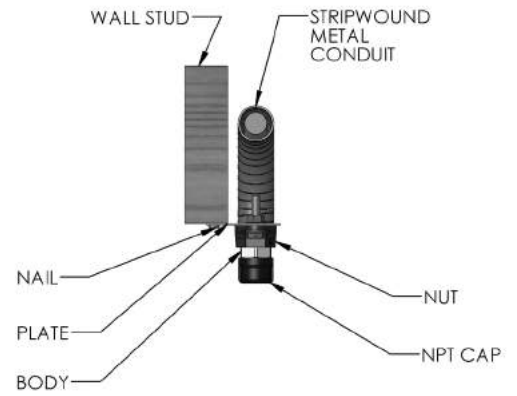

FIGURE 4.17

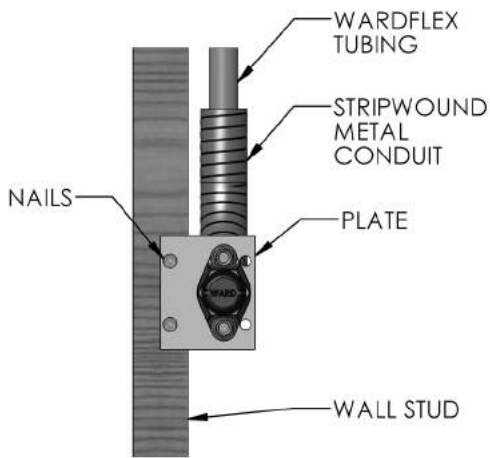

FIGURE 4.18

4.6.2 Non-Moveable Appliance

- A. WARDFlex/ WARDFlex MAX can be directly connected to a non-moveable appliance such as a furnace or water heater (Figure 4.19) (be sure to check with local code if this is acceptable prior to installation).
- B. In this type of application, no termination fitting is required and the CSST should be terminated at the appliance shut off valve.

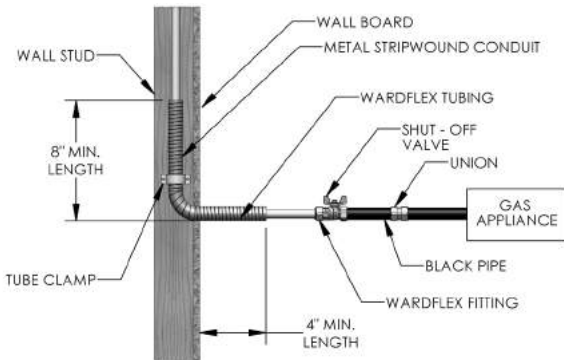

FIGURE 4.19

ATTENTION:

WARDFlex/ WARDFlex MAX CSST systems shall not be directly routed into a metallic gas appliance enclosure utilizing a metallic vent that penetrates a roofline. The WARDFlex connection shall be made outside of the metallic gas appliance enclosure to a section of rigid metallic pipe, stub-out, or termination fitting.

4.6.3 OUTDOOR APPLIANCES-BARBEQUE GRILL AND GAS LIGHT CONNECTION

- A. Movable grills shall be connected using an approved outdoor appliance connector which shall be attached to the CSST system at either a termination fitting, quick disconnect or other rigidly mounted transition fitting (figure 4.20). An approved outdoor appliance connector shall be used to connect the appliance to the gas piping system.
- B. Permanently mounted grills located on decks shall be connected to the CSST system as shown in figure 4.21 and in accordance with the manufacturer's instructions. The outdoor portion of the CSST system shall be supported against the side of any inside deck joist.
- C. Permanently mounted outdoor lights located on decks shall be connected to the CSST system in the manner as permanently mounted grills as shown in figure 4.21 and in accordance with manufacturer's instructions.
- D. Yard mounted lights shall be connected to the CSST system as shown in figure 4.22. All WARDFlex installed below grade shall be routed through nonmetallic watertight conduit and fittings protected in accordance with the requirements of section 4.3.6 Outdoor Installation.

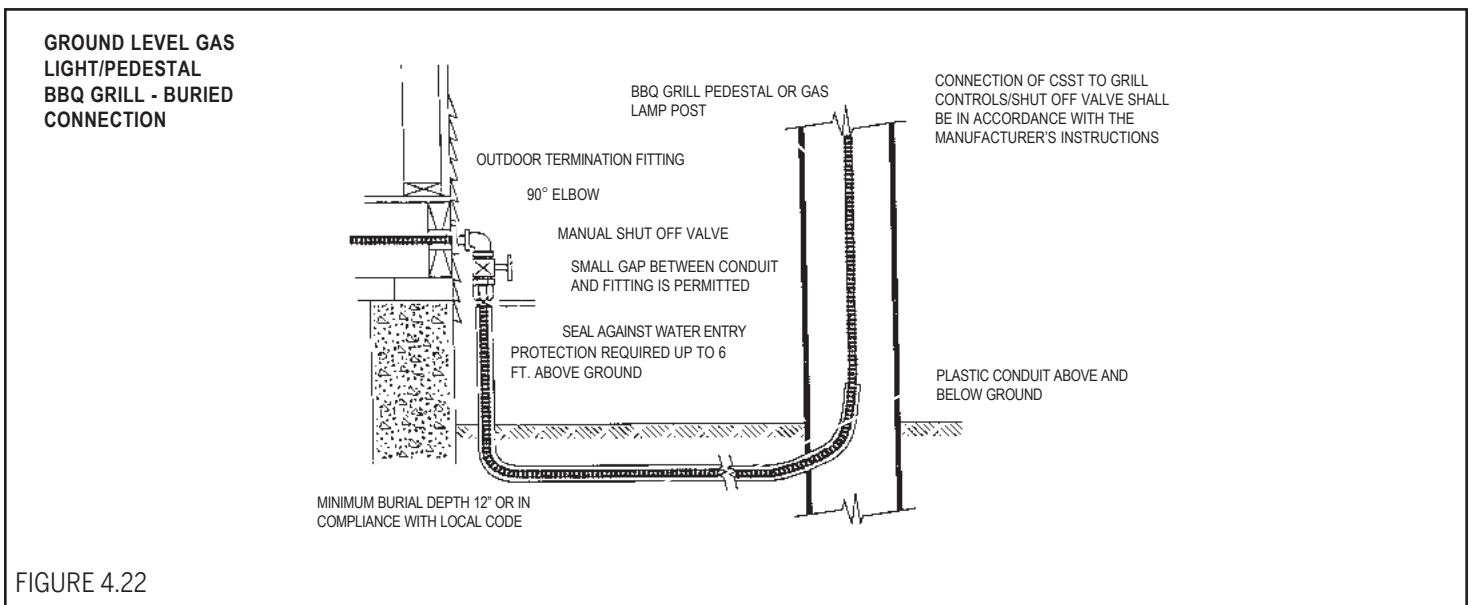
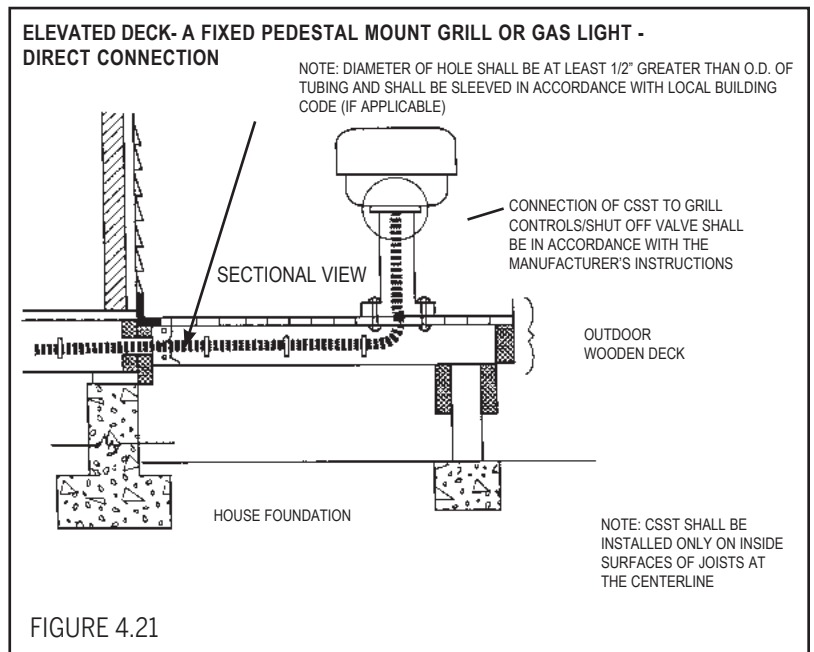
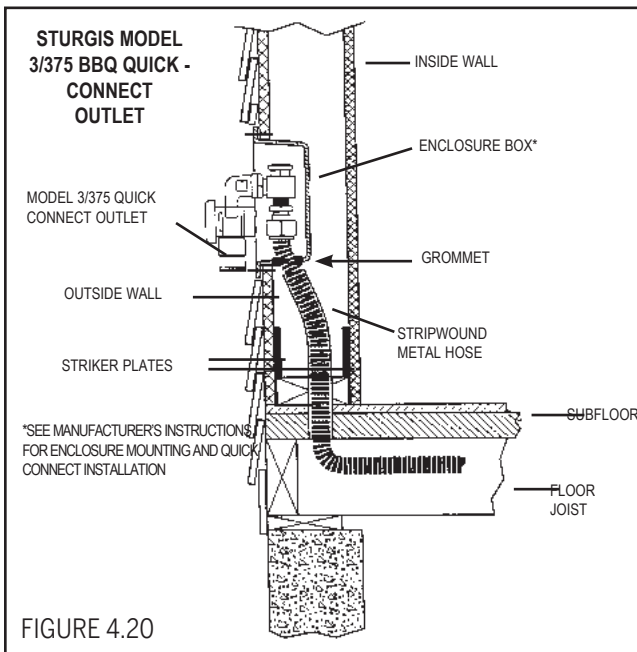

4.6.4 SPECIAL APPLICATIONS

A. Roof Top Installations

For a roof top appliance no additional mechanical protection of the tubing is required. Whenever possible, roof penetrations shall include an outdoor termination fitting and shall be located within 6 feet of the equipment to be connected as shown in figure 4.23. All long runs of tubing shall be supported in accordance with minimum support intervals in Table 4.3 and raised above the roof distance determined by local code/practice. WARDFlex routed vertically up the side of a building, to the roof, shall be protected in accordance with section 4.3.6 Outdoor Installation.

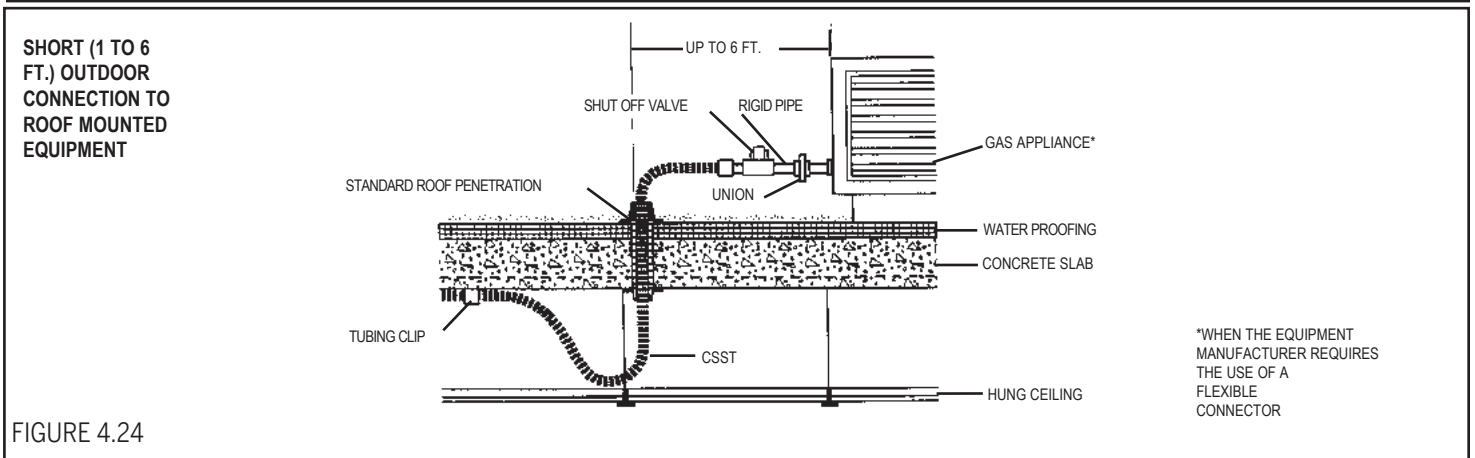
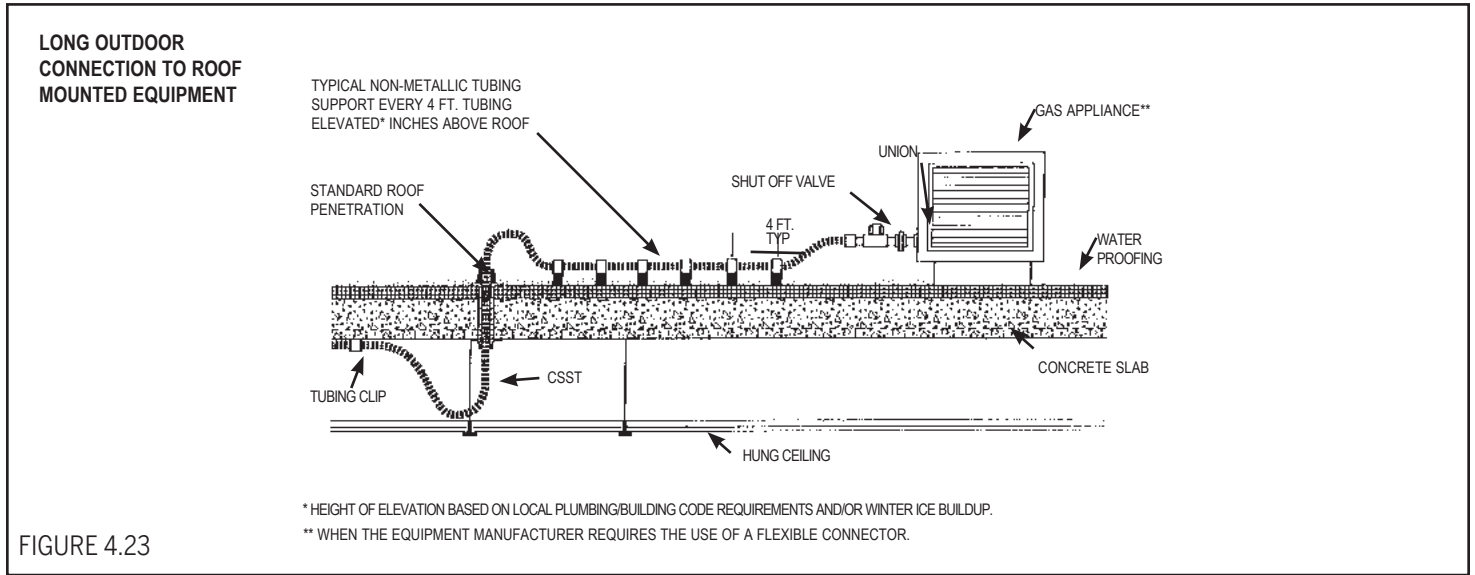

B. Infrared Heaters

Infrared heaters mounted from ceilings and walls of structures shall be connected to WARDFlex system as shown in figure 4.25 and installed in accordance with manufacturer's instructions.

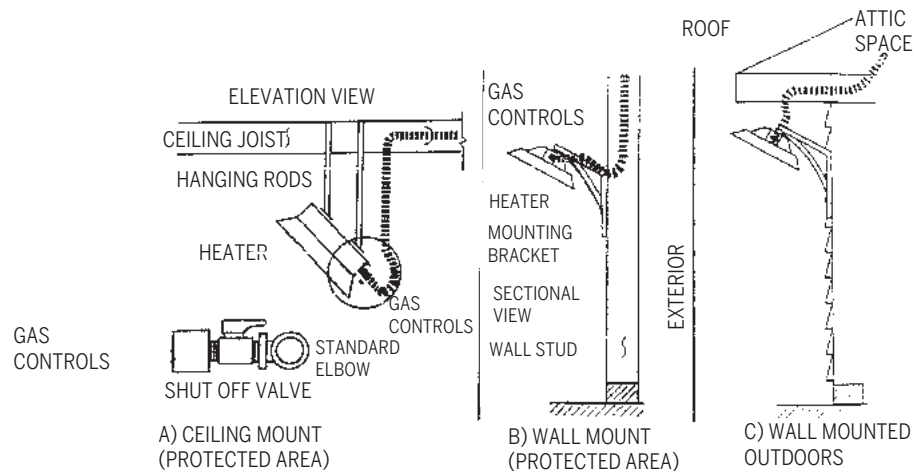

C. Pad Mounted Gas Appliances

Gas appliances mounted on concrete pads or blocks, such as heat pumps, air conditioners, pool heaters and NGV refueling systems, shall be connected to the WARDFlex system at a termination fitting using either rigid pipe or an approved outdoor appliance connector as shown in Figure 4.26. Pad mounted equipment (in most cases) is considered “fixed” if not moved for cleaning, maintenance, etc. (i.e. A/C units).

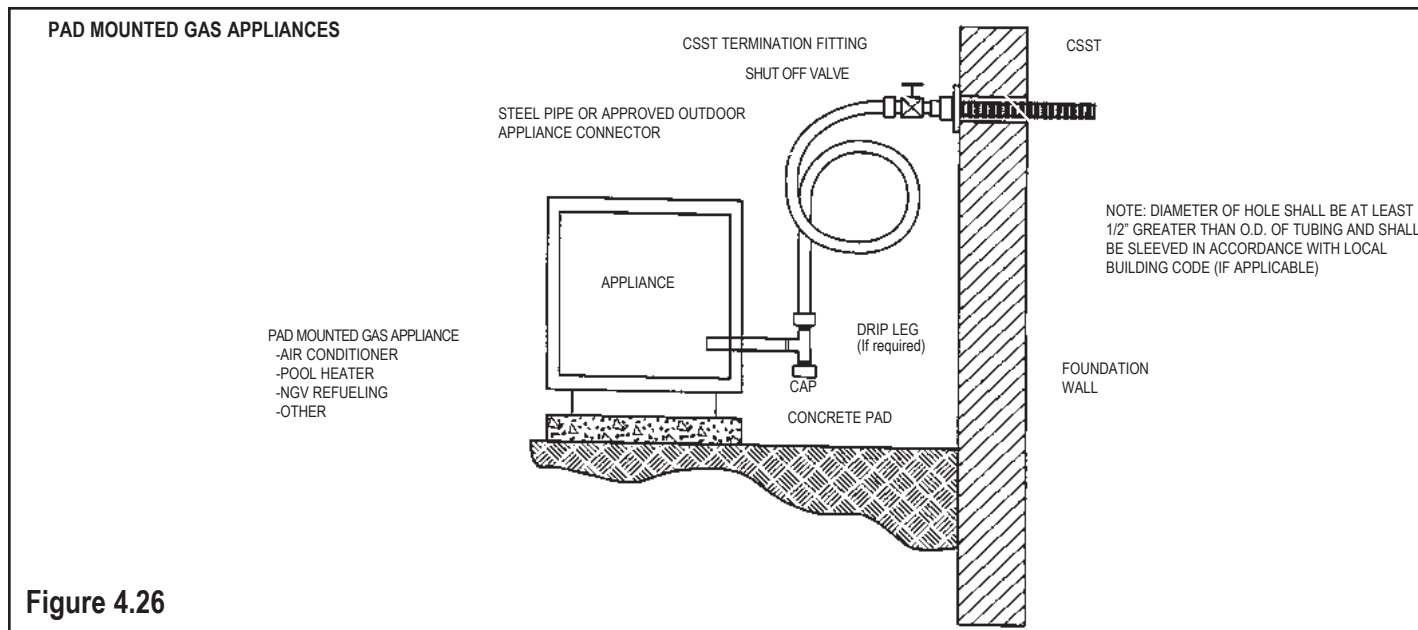

Figure 4.26

4.6.5 GAS FIREPLACES

WARDFlex/ WARDFlex MAX CSST shall not be routed directly into a metallic fireplace enclosure that utilizes a metallic vent that penetrates a roof line. The CSST connection shall be made outside of the enclosure to a section of rigid metallic pipe.

- A. When it is necessary to route WARDFlex® and WARDFlex®MAX through a metallic fireplace enclosure the coating shall be left intact and the use of nonmetallic sleeve or grommet should be used to protect the coating at the point of penetration.
- B. When routing WARDFlex® and WARDFlex®MAX through masonry construction, for connection to gas fireplaces and gas logs CSST is required to be sleeved in a non metallic conduit through the masonry structure. The plastic coating should be left intact, through the sleeved portion of the installation, and the annular space between the jacket and sleeve should be caulked at both the interior and the exterior locations.
- C. For any fireplace application where installation of CSST is desired, the WARDFlex® Fireplace Stubout should be used to terminate the CSST outside the enclosure. While other listed installation practices are acceptable, this method is preferred to prevent inadvertent damage that can be cause by the fireplace enclosure to the CSST.
- D. Adherence to local codes and manufacturer’s instructions are required, be sure to know and understand all requirements prior to installation.

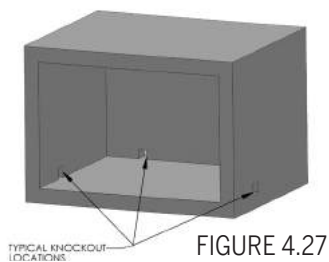

FIGURE 4.27

FIGURE 4.28

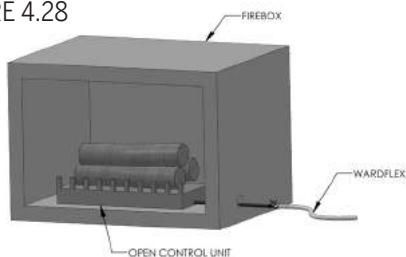
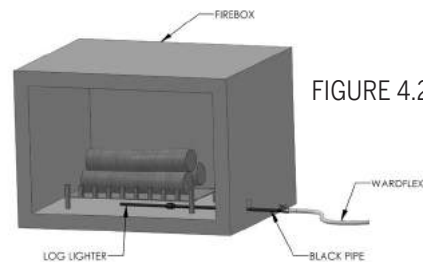

FIGURE 4.29



4.7 MANIFOLD STATION

- A. Manifolds are used where multiple tubing runs are made from a common location forming a parallel system configuration. Manifolds may be a one piece unit manufactured from malleable iron or brass. They may also be constructed as a welded fabrication of steel and subcomponents and brass or malleable iron tee's connected with pipe nipples. See figures 4.31 and 4.32 below for examples of manifolds.
- B. Manifolds shall be rigidly installed and may be mounted in any orientation. Mounting can be done with mounting brackets (figure 4.32), supplied mounting holes on manifolds (if equipped) or rigid piping into a non-movable gas appliance.
- C. Manifolds installed in low pressure applications or in locations removed from the regulator, without shutoff valves, may be concealed.
- D. A Manifold Station utilizing a pounds to inch regulator (figure 4.33) shall be installed in an accessible location to allow access to the regulator for inspection, service and replacement if required.
- E. Installation of manifold stations in an enclosure box or gas load center is permitted. Refer to local code requirements for proper installation techniques and venting requirements.

SINGLE 3 - PORT MANIFOLD WITH ADDED TEE ALLOWING FOUR PORTS

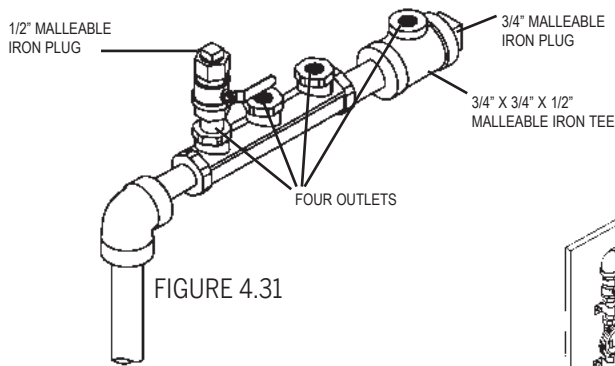

SINGLE 3 - PORT MANIFOLD WITH MANIFOLD BRACKET AND WARDFLEX GAS VALVES INSTALLED

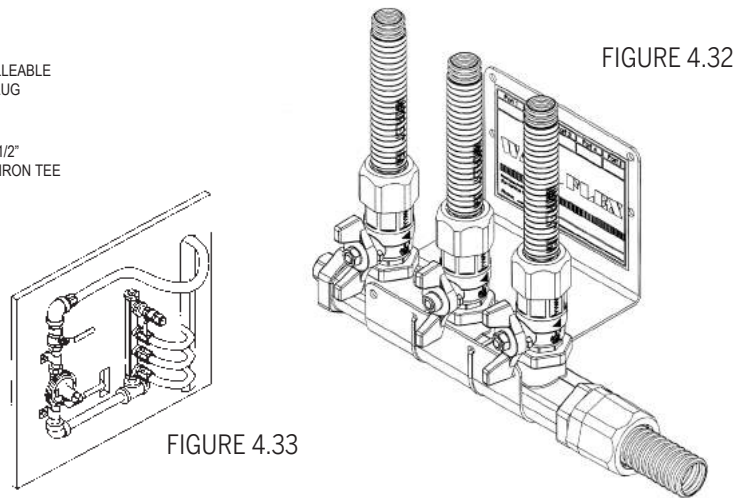

4.8 PRESSURE REGULATORS

4.8.1 Installation Requirements

A WARDFlex CSST system utilizing gas line pressures above 1/2 PSI are required to use a line pressure regulator upstream of the appliances to reduce the line pressure to less than 1/2 PSI.

The regulator shall incorporate construction which will “lock up” under no-flow conditions to limit the downstream pressure to not more than 1/2 PSIG. The regulator shall comply with a nationally recognized standard for pressure regulators.

**TYPICAL REGULATOR/
MANIFOLD CONFIGURATION
WHEN USING A VENT LIMITER**

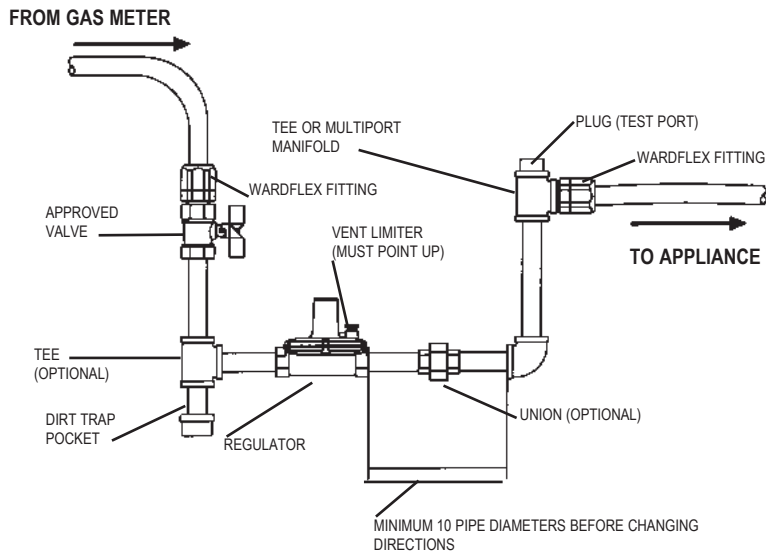

FIGURE 4.34

Regulators used to reduce elevated system pressure for appliance use must also conform to the following:

- Sized to supply the required appliance load.
- Equipped with an acceptable vent limiting device, supplied by the manufacturer, or be capable of being vented to the outside atmosphere.
- Installed in accordance with manufacturer's printed instructions.
- Installed in an accessible location.
- A CSA Design Certified shut-off valve must be installed upstream of the pressure regulator.

Regulator capacities are listed in table below.

Regulator Capacities		
Model	Maximum Individual Load	Maximum Total Load
325-3D	140,000 BTU/HR	250,000 BTU/HR
325-5E	425,000 BTU/HR	600,000 BTU/HR
325-71B	1,250,000 BTU/HR	1,250,000 BTU/HR
325-3D OP	200,000 BTU/HR	200,000 BTU/HR
325-5E OP	425,000 BTU/HR	425,000 BTU/HR

4.8.2 REGULATOR VENTING REQUIREMENTS

VENT LINES

Venting is required for all regulators to avoid a gas buildup in an enclosed area in the event that the regulator diaphragm ruptures. Vent lines should be properly sized per the manufacturers instructions and installed to ensure proper operation.

Vent Line Installation Guidelines:

- The vent line shall not be smaller than the vent connected to the pressure regulator.
- The recommended minimum size vent line for the regulator is 1/4 in. nominal ID copper tubing or other approved material. The maximum length installed for this size vent line should be less than 30 feet. Larger diameter vent lines can be used if necessary. In determining the proper size vent line for a particular installation, a test may be necessary with the vent line and regulator under normal use to ensure proper regulator operation. Consult with the regulator manufacturer for limitations of length and size of the vent line.
- The vent shall be designed and installed to prevent the entry of water, insects or other foreign materials that could cause blockage.
- Under no circumstances shall a regulator be vented to the appliance flue or building exhaust system.

VENT LIMITER OPTION:

Vent limiters are an alternate venting option available for Maxitrol 325-3L, 325-5L and 325-7L regulators. When a vent limiter is desired all installation guidelines for the vent limiter and regulator must be followed to ensure proper operation of the unit. All regulators sold by Ward Manufacturing are supplied with vent limiters.

Vent Limiter Installation Guidelines:

- Regulators must be installed in the horizontal upright position and in a well ventilated area when using a vent limiter. Consult with local code before installation.
- Only a vent limiter supplied by the regulator manufacturer may be used, no piping shall be installed between the regulator and vent limiting device.
- Leak detection fluids may not be used on vent limiters as they can cause corrosion and operational failure.
- Remove the vent limiter and check the vent opening if a leaking diaphragm is suspected. Remember, regulators will "breathe" when regulating, creating a bubble - A leak will blow bubbles constantly. Do not leak test the vent limiter with liquid leak test solution. This action will contaminate the internal ball check mechanism or plug the breathing hole, resulting in erratic regulator operation.
- Vent limiters shall not be used outside or anyplace where they are subject to damage from the environment. Vent protection devices shall be used in outdoor installations.

4.8.3 REGULATOR ADJUSTMENT

- Adjustments can be accomplished by first removing the regulator seal cap to expose the adjusting screw. Turning the screw clockwise will increase outlet pressure, turning it counter-clockwise will decrease pressure.
- If spring adjustment will not produce the desired outlet pressure, check to make sure the main supply pressure is adequate. If the main supply pressure is adequate, contact the manufacturer or WARDFlex® for other line-regulator options. Do not continue to turn regulator adjusting screw clockwise if the outlet pressure readings do not continue to increase. This may result in over firing due to loss of pressure control, should there be a subsequent increase in inlet pressure.
- The 2 PSI system pounds-to-inches regulator can be adjusted to an outlet pressure ranging between 7 to 11 inches water column pressure for natural gas and 11 to 13 inches water column for propane. The regulator must be adjusted according to the manufactures recommended procedure. A pressure gauge mounted just downstream of the regulator can monitor the set pressure under various loads.
- The regulator outlet is pre-set and labeled at the factory for either 8" natural gas or 11" propane.
- The "average" natural gas appliance is designed to operate at 3 to 6 inches water column pressure, and a pressure difference of 1 to 2 inches of water column across the appliance regulator which will prevent slow regulator response.

Thus, the appliance regulator will operate best at 4 to 7 inches W.C. inlet pressure. The pounds to-inches system regulators for natural gas are set to deliver 8 inches of W.C. outlet pressure under load to allow for 1-2 inches of W.C. pressure drop in the tubing.

- The average propane gas appliance is designed to operate at 10 to 10 1/2 inches water column pressure. Thus, the pounds to inches regulators for propane gas are set to deliver 11 inches water column outlet pressure under load to allow for 0.5 inches water column pressure drop in the tubing.

4.8.4 OVER PRESSURIZATION PROTECTION

Gas systems using pressures above 2 PSI up to 5 PSI must use OPD (Over Pressure Protection Devices).

4.9 UNDERGROUND INSTALLATIONS

4.9.1 GENERAL INFORMATION



WARDFlex/WARDFlex MAX may not be directly buried or directly embedded in or under concrete slabs.



WARDFlex/WARDFlex MAX may be installed underground in/under a concrete slab when routed through previously embedded, non-metallic, watertight conduit such as PVC pipe. Conduit used to protect WARDFlex/WARDFlex MAX when installed underground, must have an I.D. 1/2" larger than the O.D of the CSST.

For outdoor underground installations, the annular space between the CSST and the conduit must be sealed to prevent entrance of moisture, dirt, debris, and insects. The use of a mechanical joint, coupling, or tee is prohibited inside the conduit.

For indoor buried installations, Ward Manufacturing does not require the conduit to be vented to the outside. Due to its continuous construction and availability in long run lengths, no fittings are permitted inside the conduit. This eliminates the possibility of gas build up caused by leaking fittings after the system has been placed in service. In the event that local code requires the conduit to be vented, the use of a tee designed for use with non-metallic conduit may be placed at the termination end of the conduit. One end of the tee should be sealed while the other outlet can be used to connect a vent line that is routed outside (figure 4.35). Vent lines routed to the outside of a structure must be installed in such a manner to prevent entrance of moisture, dirt, debris, and insects.

Burial Depths:

- Outdoors – minimum of 12"
- In slab – 1-1/2" minimum concrete coverage.
- Under slab – no minimum burial depth below slab or in compliance with local codes.

Conduit Termination Height:

- Indoors – Conduit to extend a minimum of 1" above finished floor height.
- Outdoors – Conduit to extend a minimum of 4" above finished grade.

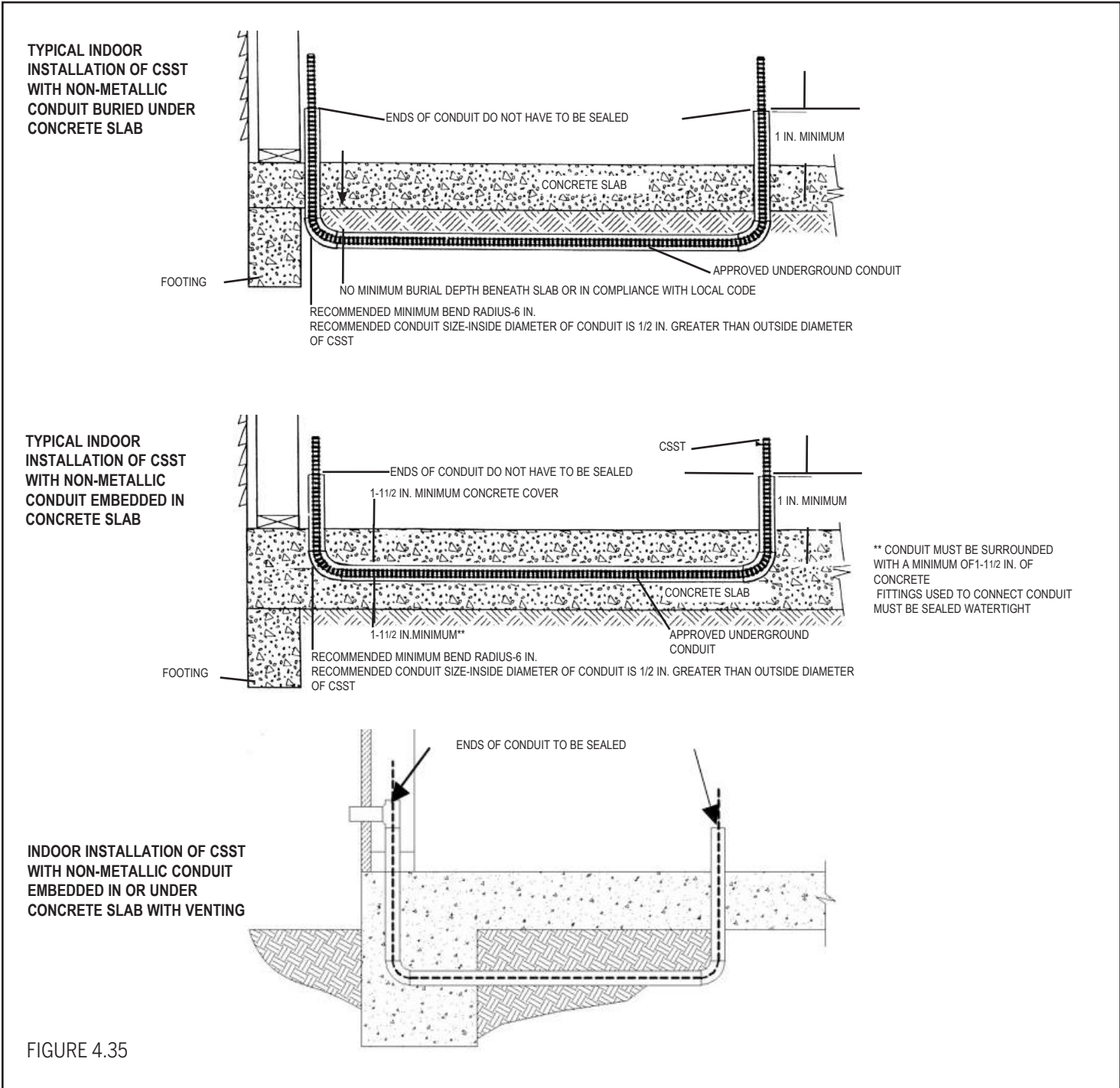

FIGURE 4.35

4.10 WARDFlex® CSST Electrical Bonding

- Ward Manufacturing requires the direct bonding of all natural and LP gas piping systems incorporating yellow coated WARDFlex® Corrugated Stainless Steel Tubing (CSST) whether or not the piping system is connected to an electrically powered gas appliance. Direct bonding is included as part of the manufacturer's requirements for both single family and multi-family buildings. A person knowledgeable about electrical system design, local electrical code, and these requirements should specify the bonding for commercial applications. WARDFlex® CSST installed inside or attached to the exterior of a building or structure shall be electrically continuous and directly bonded, by a qualified person, to the ground system of the building. The gas piping is considered to be directly bonded when installed in accordance with the following instructions:
- A bonding conductor is permanently and directly connected to the electrical service grounding system. This can be achieved through a connection to the electrical service equipment enclosure, the grounded conductor at the electrical service, the grounding electrode conductor (where of sufficient size) or to the one or more grounding electrodes used.
- A single bond connection is made to the building gas piping downstream of the utility meter or second stage regulator (LP systems), or downstream of the gas meter of each individual housing unit within a multi-family structure. A "daisy chain" configuration of the bonding conductor is permitted for multi-meter installations. A bonding connection shall not be made to the underground, natural gas utility service line or the underground supply line from a LP storage tank.
- The bonding conductor is not to be smaller than a #6 AWG copper wire or equivalent. The bonding conductor is installed and protected in accordance with the NEC.
- When connecting the bonding clamp to one of the approved locations noted below choose a connection location close the electrical service to utilize as short of conductor length as possible. The bonding conductor may be attached, to an accepted location, anywhere in the gas piping system to aid in reducing the bonding conductor length. The length of the bonding conductor shall not exceed 75 feet.
- The bonding conductor is attached in an approved manner in accordance with NEC and the point of attachment for the bonding conductor is accessible.
- Bonding/grounding clamp used is listed to UL 467 or other acceptable national standards.

A bonding clamp which is listed for the intended connection location and is manufactured with an appropriate and code listed material is to be attached at one point within the piping system to a segment of rigid pipe, a pipe component such as a nipple, fitting, manifold, or CSST fitting. The bonding clamp must be attached such that metal to metal contact is achieved with the steel pipe component. Remove any paint or applied coating on the pipe surface beneath the clamp. See Figure 4.41 for guidance. The corrugated stainless steel tubing portion of the gas piping system shall not be used as the point of attachment of the bonding clamp at any location along its length.

Proper grounding and bonding may reduce the risk of damage and fire from a lightning strike. Lightning is a highly destructive force. Even a nearby lightning strike that does not strike a structure directly can cause metallic systems in the structure to become energized. If these types of systems are not properly bonded, the difference in potential between the systems may cause the charge to arc from one system to another system. Arcing can cause damage to CSST. Bonding and grounding as set forth above should reduce the risk of arcing and related damage.

Depending upon conditions specific to the location in which the WARDFlex gas piping system is being installed, including but not limited to whether or not the area is prone to lightning, the owner of the structure should consider whether or not a lightning protection system is necessary or appropriate to protect the structure. Lightning protections are beyond the scope of this bulletin, but are covered by NFPA 780, which is the Standard for the Installation of Lightning Protection Systems, and other standards. Consult with your local Building Official to determine if a lightning protection system is warranted.

Piping systems incorporating black coated WARDFlex® MAX CSST have

no additional bonding requirements imposed by the manufacturer. WARDFlex® MAX may be bonded in accordance with the National Electrical Code NFPA 70 Article 250.104 in the same manner as rigid metallic piping systems. In the event that additional bonding of black coated WARDFlex® MAX is required by local code, the same requirements stated in this section for the direct bonding of yellow coated WARDFlex® shall be followed. It is the responsibility of the trained installer to verify all local code compliance.

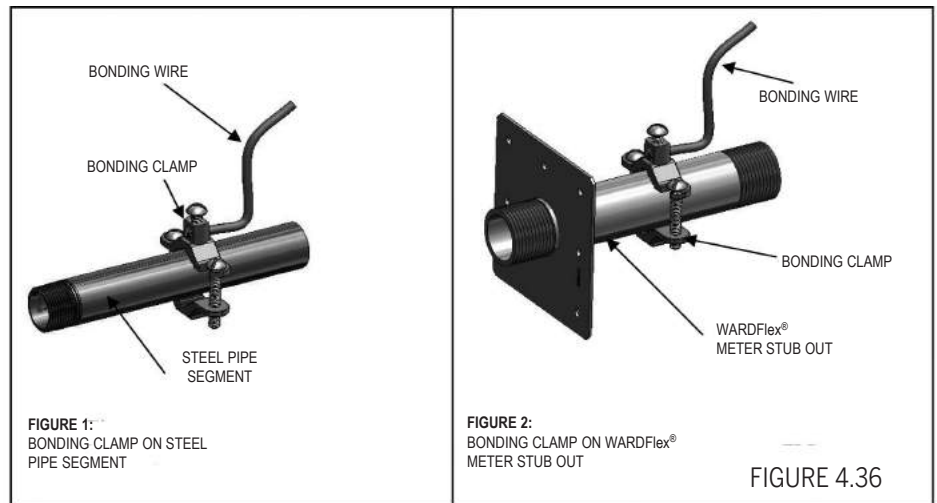

5.0 INSPECTION, REPAIR AND REPLACEMENT

5.1 MINIMUM INSPECTION REQUIREMENTS

If the tubing is damaged refer to the following subsections to determine the severity of damage and, if necessary the method of repair.

Classification of Repairs

- No repairs or replacement of the tubing is necessary if the tubing is only slightly dented by crushing as indicated in Figure 5.1.

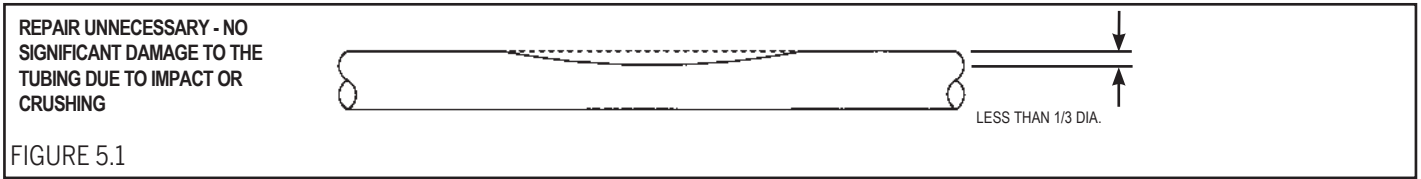

- The tubing must be repaired or replaced under the following circumstances:
- The tubing has been significantly damaged (Figure 5.2).
- The tubing has been punctured.
- The tubing has been bent beyond its minimum bend radius so that a crease or kink appears (Figure 5.3).

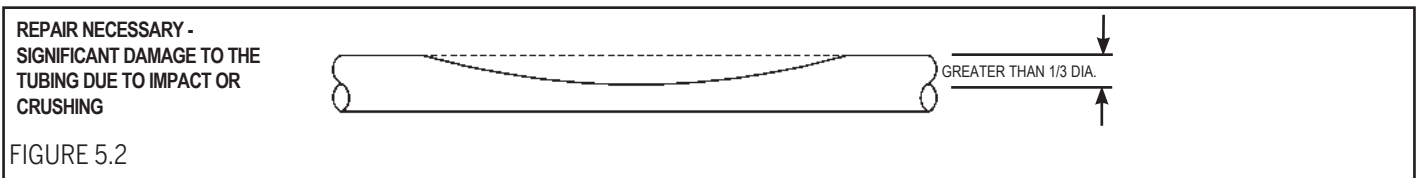

5.2 REPAIR/REPLACEMENT OF DAMAGED TUBING

Several methods of repair are discussed below depending on the nature of damage.

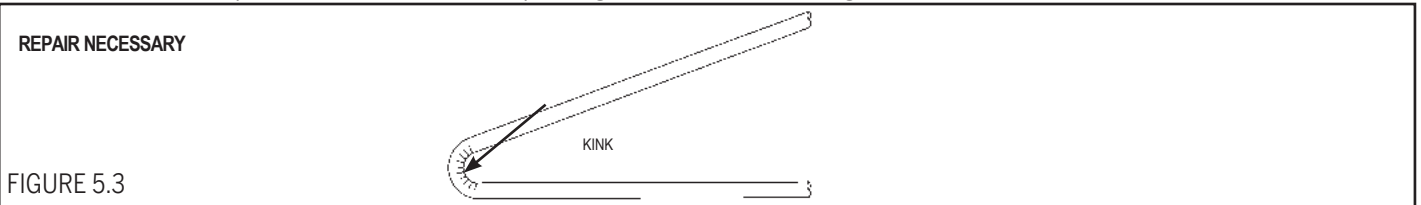

WARDFlex® AND OTHER DESIGNS ARE NOT INTERCHANGEABLE. DO NOT MIX COMPONENTS.

In the case of the Outdoor Termination Fitting, install new O-Rings. The installer shall determine the most reliable and economical method of repair using one of the following methods:

- Replace the entire tubing run. In most cases, when the tubing run is short and easily accessible, it can be replaced faster and more economically than repairing the damaged section. This is the preferred method because extra fittings are not required.
- Repair the damaged section. The damaged tubing can be repaired by each of following two methods.

Method 1: Remove the section of tubing which is damaged and reconnect the new ends with a single mechanical coupling. Use this repair method if the damaged section is small and if there is enough slack tubing in the run to make-up for the removed damaged length.

Method 2: Remove the section of tubing which is damaged and repair/replace as illustrated in figure 5.4.

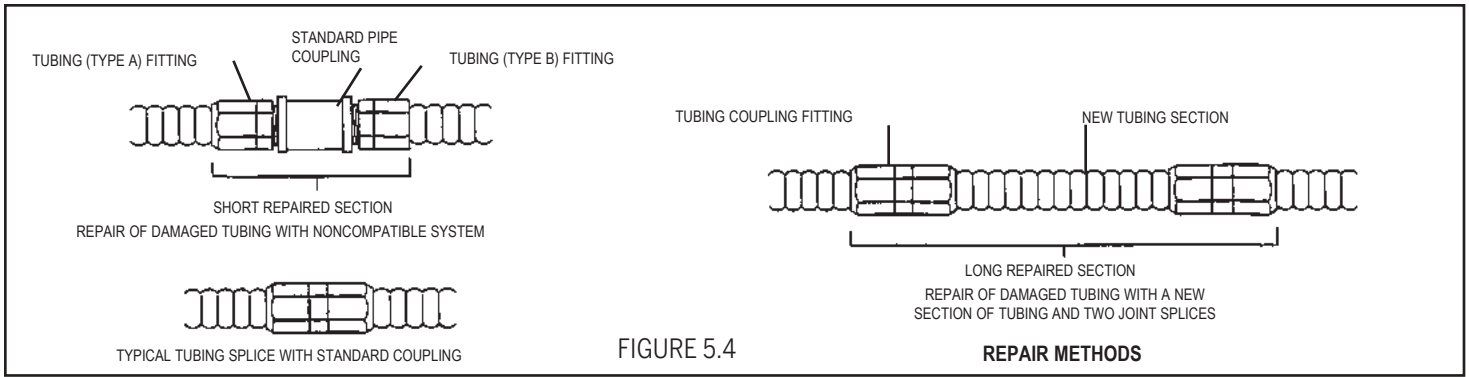

Appliance Connection and Leakage Check Procedure

- After the pressure test, inspection and final construction is complete (finished interior walls), connect the appliances to the tubing system.
- Turn the gas on at the meter and inspect for leaks before operating the appliance. Regulator adjustment may be necessary on 2 PSIG systems (refer to manufacturer's instruction) to obtain proper appliance line pressure.
- Connections made at each appliance must be checked for leaks with a non-corrosive commercial leak-testing fluid due to lack of sensitivity in solutions using soap buds or household detergents as stated in ASTM E515-05 section 9.3. Any leak detection solution coming in contact with the WARDFLEX System should have a sulfur and halogen content of less than 10 ppm of each (ASTM E515-05 section 7.4).
- Before placing appliances in operation, the piping system should be purged. This displaces the air in the system with fuel gas. Purge into a well ventilated area.

6.0 TESTING

6.1 PRESSURE TESTING AND INSPECTION PROCEDURE

- The final installation is to be inspected and tested for leaks at 1 1/2 times the maximum working pressure, but not less than 3 PSIG, using procedures specified in Chapter 8 "Inspection, Testing and Purging" of the National Fuel Gas Code, NFPA 54/ANSI Z223.1 In Canada, refer to the applicable sections of the CAN/CGA - B149 Installation codes.
- Maximum test pressures recommended for all WARDFlex® and WARDFlex® MAX sizes is - 40 PSI. Excess pressure will permanently distort tubing.
- Do not connect appliances until after pressure test is completed.
- Inspect the installed system to ensure:
 - Presence of listed striker plates and other protective devices at all required locations.
 - Acceptable physical condition of the tubing.
 - Presence of fittings (with nut bottomed out to the body).
 - Correct regulator and manifold arrangement with proper venting requirements.
 - All gas outlets for appliance connections should be capped during pressure testing.
 - Pressure testing should be performed during rough construction of the facility (before interior walls are finished). This will permit a more complete inspection of the piping system during the pressure testing.
- The elevated pressure system requires a two-part pressure test. (See Figure 6.1)
 - The first part is performed on the elevated pressure section, between the meter connection and the pressure regulator.
 - The second part is performed on the low pressure section, between the pressure regulator and the individual gas appliance outlets.

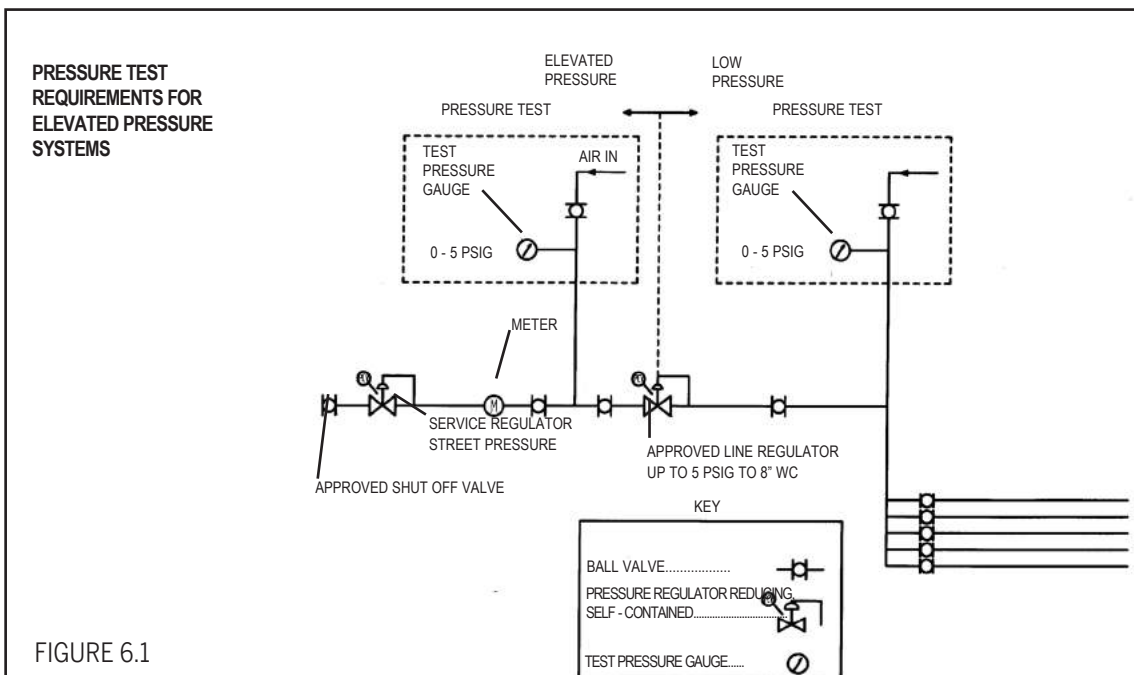

7.0 SIZING TABLES (NATURAL AND LP)

Important Note:

When choosing a pressure drop to size the WARDFlex® system the minimum operating pressure of the unit must be considered. Choosing a pressure drop that will reduce the supply pressure below the minimum operating pressure of the unit will cause the unit to perform poorly or not at all.

Example:

System Supply Pressure: 7 inches W.C.

Unit minimum operating pressure: 5" W.C.

The use of a 3 inch W.C. pressure drop would result in a minimum inlet pressure at the unit of 4 inches W.C. In this case an alternate pressure drop of 2 inches or less should be selected to meet the minimum operating pressure of the unit.

7.1 NATURAL GAS - LOW PRESSURE

Maximum Capacity of WARDFlex CSST in Cubic Feet per Hour (CFH) of Natural Gas
(Approximately 1000 BTU per cubic foot)

Table A-1

Gas Pressure of: **0.5 psi or Less**
Pressure Drop of: **0.5 inches W.C.**

(based on a 0.60 specific gravity gas)

Size	10A	15A	20A	25A	32A	38A	50A
	3/8"	1/2"	3/4"	1"	1-1/4"	1-1/2"	2"
EHD	15	19	25	31	39	48	62
5	63	155	270	497	1150	2167	3993
10	44	104	192	357	830	1544	2880
15	36	83	157	294	686	1267	2379
20	31	70	137	256	600	1101	2077
25	27	62	122	230	540	987	1870
30	25	56	112	212	496	903	1716
40	21	47	97	185	433	784	1498
50	19	42	87	167	390	703	1348
60	17	39	80	153	358	643	1237
70	16	36	74	143	333	597	1151
80	15	33	69	134	313	559	1080
90	14	31	65	127	296	528	1022
100	13	30	62	121	281	501	972
125	12	27	57	109	253	452	875
150	10	24	53	100	233	419	803
200	9	21	47	88	203	372	701
250	8	19	43	79	183	339	631
300	7	17	40	73	169	314	579
400	6	15	36	63	148	279	506
500	5	13	33	57	134	254	455
600	5	12	31	52	123	236	418
700	4	11	29	49	115	221	388
800	4	10	27	46	108	209	365
900	4	10	26	43	102	199	345
1000	4	9	25	41	97	190	328
1100	3	9	24	40	93	183	314
1200	3	8	23	38	90	177	301
1300	3	8	23	37	86	171	290
1400	3	8	22	35	84	166	280
1500	3	7	21	34	81	161	271

Table A-2

Gas Pressure of: **0.5 psi or Less**
Pressure Drop of: **1.0 inches W.C.**

(based on a 0.60 specific gravity gas)

Size	10A	15A	20A	25A	32A	38A	50A
	3/8"	1/2"	3/4"	1"	1-1/4"	1-1/2"	2"
EHD	15	19	25	31	39	48	62
5	90	192	379	692	1592	3040	5536
10	63	135	270	497	1150	2167	3993
15	51	110	221	409	951	1777	3298
20	44	95	192	357	830	1544	2880
25	39	85	172	321	748	1385	2592
30	36	77	157	294	686	1267	2379
40	31	67	137	256	600	1101	2077
50	27	60	122	230	540	987	1870
60	25	55	112	211	496	903	1716
70	23	51	104	196	461	837	1595
80	21	47	97	184	433	784	1498
90	20	45	92	174	410	740	1417
100	19	42	87	165	390	703	1348
125	17	38	78	148	351	631	1214
150	15	34	71	136	322	577	1114
200	13	30	62	118	281	501	972
250	12	27	56	106	253	449	875
300	10	24	51	97	233	411	803
400	9	21	44	85	203	357	701
500	8	19	40	76	183	320	631
600	7	17	36	70	168	293	579
700	7	16	34	65	156	272	539
800	6	15	32	61	147	254	506
900	6	14	30	57	139	240	478
1000	5	13	28	55	132	228	455
1100	5	12	27	52	126	218	435
1200	5	12	26	50	121	209	418
1300	5	11	25	48	117	201	402
1400	4	11	24	46	113	193	388
1500	4	11	23	45	109	187	376

Table includes losses for four 90 degree bends and 2 end fittings. To compute flow capacity for tubing runs with a larger number of bends and/or fittings, add the appropriate number of feet to the actual run length using the following formula:

$$L = 1.3(n) \quad L = \text{Numbers of feet to be added to actual run length.} \quad n = \text{Number of bends and/or fittings over six.}$$

Maximum Capacity of WARDFlex CSST in Cubic Feet per Hour (CFH) of Natural Gas (Approximately 1000 BTU per cubic foot)

Table A-3

Size	Gas Pressure of: 0.5 psi or Less						
	10A 3/8"	15A 1/2"	20A 3/4"	25A 1"	32A 1-1/4"	38A 1-1/2"	50A 2"
EHD	15	19	25	31	39	48	62
5	229	479	911	1687	3694	7294	12991
10	160	336	649	1182	2668	5199	9293
15	130	273	532	964	2205	4265	7676
20	112	236	462	840	1926	3705	6703
25	99	211	414	755	1735	3323	6033
30	90	192	379	692	1592	3040	5536
40	78	166	329	603	1391	2641	4834
50	69	148	295	542	1253	2368	4352
60	63	135	270	497	1150	2167	3993
70	58	126	250	462	1070	2009	3713
80	54	118	234	433	1005	1898	3487
90	51	111	221	409	951	1811	3298
100	48	106	210	389	905	1736	3139
125	43	95	188	350	821	1588	2825
150	39	87	172	321	763	1476	2592
200	34	75	149	279	680	1316	2264
250	30	68	134	251	622	1203	2038
300	27	62	122	230	578	1119	1870
400	23	54	106	200	515	997	1633
500	21	48	95	180	471	912	1470
600	19	44	87	165	438	848	1348
700	17	41	81	154	412	797	1254
800	16	38	76	144	390	755	1177
900	15	36	71	137	372	721	1114
1000	14	34	68	130	357	691	1060
1100	14	33	65	124	344	665	1013
1200	13	31	62	119	332	642	972
1300	12	30	60	115	321	622	936
1400	12	29	57	111	312	604	904
1500	12	28	56	108	304	587	875

Table

includes losses for four 90 degree bends and 2 end fittings. To compute flow capacity for tubing runs with a larger number of bends and/or fittings, add the appropriate number of feet to the actual run length using the following formula:
 $L = 1.3(n)$ L = Numbers of feet to be added to actual run length.
 n = Number of bends and/or fittings over six.

Maximum Capacity of WARDFlex CSST in Cubic Feet per Hour (CFH) of Natural Gas (Approximately 1000 BTU per cubic foot)

Table A-4

Size	Gas Pressure of: 0.5 psi or Less						
	10A 3/8"	15A 1/2"	20A 3/4"	25A 1"	32A 1-1/4"	38A 1-1/2"	50A 2"
EHD	15	19	25	31	39	48	62
5	160	336	649	1384	2668	5199	9293
10	112	236	462	957	1926	3705	6703
15	90	192	379	771	1592	3040	5536
20	78	166	329	662	1391	2641	4834
25	69	148	295	588	1253	2368	4352
30	63	135	270	533	1150	2167	3993
40	54	118	234	458	1005	1882	3487
50	48	106	210	406	905	1688	3139
60	44	97	192	369	830	1544	2880
70	41	90	178	340	772	1432	2678
80	38	85	167	316	725	1342	2515
90	36	80	157	297	690	1267	2379
100	34	76	149	281	660	1203	2264
125	30	69	134	251	601	1079	2038
150	27	63	122	230	557	987	1870
200	23	55	106	200	493	857	1633
250	21	50	95	180	449	769	1470
300	19	45	87	165	416	703	1348
400	16	40	76	144	369	615	1177
500	14	36	68	129	336	555	1060
600	13	33	62	118	311	510	972
700	12	30	57	110	291	475	904
800	11	29	54	103	275	446	849
900	10	27	51	97	262	423	803
1000	10	26	48	93	251	403	764
1100	9	25	46	89	241	385	731
1200	9	24	44	85	232	370	701
1300	9	23	43	82	224	357	675
1400	8	22	41	79	218	345	652
1500	8	21	40	76	211	334	631

Table includes losses for four 90 degree bends and 2 end fittings. To compute flow capacity for tubing runs with a larger number of bends and/or fittings, add the appropriate number of feet to the actual run length using the following formula:
 $L = 1.3(n)$ L = Numbers of feet to be added to actual run length.
 n = Number of bends and/or fittings over six.

7.2 NATURAL GAS - ELEVATED PRESSURE

Maximum Capacity of WARDFlex CSST in Cubic Feet per Hour (CFH) of Natural Gas (Approximately 1000 BTU per cubic foot)

Table A-5

		Gas Pressure of: 5.0 psi					
		Pressure Drop of: 3.5 psi					
		<i>(based on a 0.60 specific gravity gas)</i>					
Size	10A 3/8"	15A 1/2"	20A 3/4"	25A 1"	32A 1-1/4"	38A 1-1/2"	50A 2"
EHD	15	19	25	31	39	48	62
5	965	1975	3554	7030	13794	28406	50320
10	675	1388	2532	4927	9879	20248	35917
15	547	1129	2076	4002	8147	16610	29487
20	472	975	1804	3453	7118	14432	25636
25	420	870	1617	3080	6410	12942	22999
30	382	793	1479	2805	5884	11839	21046
40	330	685	1285	2420	5201	10287	18298
50	294	611	1152	2158	4728	9225	16426
60	267	557	1054	1966	4374	8439	15199
70	247	515	977	1816	4095	7872	14233
80	230	481	915	1696	3868	7449	13446
90	217	453	864	1597	3679	7094	12787
100	205	430	821	1517	3517	6791	12226
125	183	383	736	1360	3197	6192	11117
150	166	349	673	1244	2958	5742	10287
200	143	303	585	1080	2616	5097	9100
250	128	272	528	969	2378	4647	8275
300	116	249	486	886	2200	4309	7656
400	100	216	426	770	1945	3825	6773
500	89	194	385	690	1769	3488	6159
600	81	178	354	631	1636	3234	5699
700	75	165	330	585	1532	3034	5337
800	70	154	311	548	1447	2871	5041
900	66	146	295	518	1376	2734	4795
1000	62	139	281	492	1315	2618	4584
1100	59	132	269	469	1263	2516	4402
1200	56	127	259	450	1217	2427	4242
1300	54	122	249	432	1176	2348	4099
1400	52	118	241	417	1139	2277	3972
1500	50	114	234	403	1106	2213	3857

Table includes losses for four 90 degree bends and 2 end fittings. To compute flow capacity for tubing runs with a larger number of bends and/or fittings, add the appropriate number of feet to the actual run length using the following formula:
 $L = 1.3(n)$ L = Numbers of feet to be added to actual run length.
 n = Number of bends and/or fittings over six.

Maximum Capacity of WARDFlex CSST in Cubic Feet per Hour (CFH) of Natural Gas (Approximately 1000 BTU per cubic foot)

Table A-6

		Gas Pressure of: 2.0 psi					
		Pressure Drop of: 1.0 psi					
		<i>(based on a 0.60 specific gravity gas)</i>					
Size	10A 3/8"	15A 1/2"	20A 3/4"	25A 1"	32A 1-1/4"	38A 1-1/2"	50A 2"
EHD	15	19	25	31	39	48	62
5	505	1044	1926	3698	7578	15405	27356
10	353	733	1372	2592	5473	10981	19526
15	286	596	1125	2105	4524	9008	16030
20	247	515	977	1816	3953	7827	13937
25	220	460	876	1620	3560	7019	12503
30	200	419	801	1475	3268	6421	11442
40	172	362	696	1273	2855	5579	9948
50	154	323	624	1135	2571	5003	8954
60	140	294	571	1034	2360	4576	8217
70	129	272	529	959	2195	4244	7641
80	120	254	496	900	2062	3976	7175
90	113	239	468	851	1951	3754	6787
100	107	227	445	809	1857	3566	6459
125	95	202	398	727	1672	3198	5814
150	87	184	364	666	1535	2925	5355
200	75	159	317	581	1341	2542	4658
250	67	142	284	522	1207	2279	4193
300	61	129	260	478	1108	2085	3848
400	52	112	225	417	968	1811	3360
500	46	100	202	375	872	1624	3024
600	42	91	185	343	800	1486	2775
700	39	84	171	319	744	1378	2581
800	36	79	160	299	699	1291	2423
900	34	74	151	283	661	1219	2292
1000	32	70	144	269	630	1158	2181
1100	31	67	137	257	602	1105	2085
1200	29	64	131	247	578	1059	2002
1300	28	62	126	237	557	1018	1927
1400	27	60	122	229	537	982	1861
1500	26	58	118	222	520	950	1802

Table includes losses for four 90 degree bends and 2 end fittings. To compute flow capacity for tubing runs with a larger number of bends and/or fittings, add the appropriate number of feet to the actual run length using the following formula:
 $L = 1.3(n)$ L = Numbers of feet to be added to actual run length.
 n = Number of bends and/or fittings over six.

**Maximum Capacity of WARDFlex CSST in Cubic Feet per Hour (CFH) of Natural Gas
(Approximately 1000 BTU per cubic foot)**

Table A-7

Size		Gas Pressure of: 10.0 psi					Pressure Drop of: 7.0 psi							
		10A 3/8"	15A 1/2"	20A 3/4"	25A 1"	32A 1-1/4"	38A 1-1/2"	50A 2"	10A 3/8"	15A 1/2"	20A 3/4"	25A 1"	32A 1-1/4"	38A 1-1/2"
EHD	15	19	25	31	39	48	62							
	5	2891	4842	10050	19789	38067	59564							
	10	2047	3552	7165	14648	28295	45392							
	15	1672	2963	5879	12284	23787	38721							
	20	1449	2606	5109	10842	21031	34592							
	25	1297	2358	4582	9842	19115	31695							
	30	1184	2174	4192	9093	17681	29508							
	40	1026	1911	3643	8026	15632	26361							
	50	918	1730	3267	7285	14208	24153							
	60	838	1594	2989	6730	13142	22487							
	70	776	1488	2772	6295	12303	21169							
	80	726	1402	2597	5940	11619	20089							
	90	685	1330	2452	5644	11048	19183							
	100	650	1269	2329	5392	10561	18407							
	125	581	1148	2089	4894	9599	16865							
	150	531	1058	1911	4522	8878	15702							
	200	460	931	1660	3991	7850	14027							
	250	412	842	1489	3623	7135	12852							
	300	376	776	1362	3347	6599	11966							
	400	326	683	1184	2954	5834	10690							
	500	291	618	1062	2681	5303	9794							
	600	266	569	971	2477	4905	9119							
	700	246	531	901	2317	4592	8584							
	800	230	501	844	2187	4337	8146							
	900	217	475	797	2078	4123	7778							
	1000	206	453	757	1985	3941	7464							
	1100	197	434	722	1904	3784	7190							
	1200	188	417	692	1834	3646	6949							
	1300	181	403	666	1771	3523	6734							
	1400	174	390	642	1715	3413	6541							
	1500	168	378	621	1664	3313	6367							

Tubing Length (Ft.)

Table A-8

Size		Gas Pressure of: 25.0 psi					Pressure Drop of: 10.0 psi							
		10A 3/8"	15A 1/2"	20A 3/4"	25A 1"	32A 1-1/4"	38A 1-1/2"	50A 2"	10A 3/8"	15A 1/2"	20A 3/4"	25A 1"	32A 1-1/4"	38A 1-1/2"
EHD	15	19	25	31	39	48	62							
	5	4686	9174	15713	31976	43967	74301							
	10	3290	6154	11195	23456	34615	58742							
	15	2676	4872	9182	19568	30096	51198							
	20	2310	4128	7977	17207	27253	46440							
	25	2062	3630	7152	15573	25233	43057							
	30	1879	3268	6542	14354	23695	40476							
	40	1622	2769	5683	12622	21456	36715							
	50	1448	2435	5096	11424	19866	34040							
	60	1319	2192	4661	10530	18655	32000							
	70	1219	2006	4323	9828	17689	30371							
	80	1139	1857	4049	9259	16893	29026							
	90	1073	1736	3823	8784	16220	27890							
	100	1016	1633	3631	8380	15641	26912							
	125	907	1436	3255	7584	14482	24951							
	150	826	1293	2978	6991	13599	23456							
	200	714	1096	2587	6147	12314	21276							
	250	637	963	2319	5564	11402	19726							
	300	580	867	2122	5128	10706	18544							
	400	501	735	1843	4509	9695	16820							
	500	447	646	1652	4081	8976	15595							
	600	407	582	1511	3762	8429	14660							
	700	376	532	1402	3511	7993	13914							
	800	352	493	1313	3308	7633	13298							
	900	331	460	1240	3138	7329	12777							
	1000	314	433	1177	2994	7067	12329							
	1100	299	410	1124	2869	6839	11937							
	1200	286	390	1077	2759	6636	11590							
	1300	274	372	1035	2662	6456	11280							
	1400	264	357	999	2576	6293	11000							
	1500	255	343	965	2497	6145	10746							

Tubing Length (Ft.)

Tables include losses for four 90° bends and two end fittings.

Table includes losses for four 90 degree bends and 2 end fittings. To compute flow capacity for tubing runs with a larger number of bends and/or fittings, add the appropriate number of feet to the actual run length using the following formula:

L = 1.3 (n) L = Numbers of feet to be added to actual run length. n = Number of bends and/or fittings over six.

7.3 PROPANE GAS - LOW PRESSURE
Maximum Capacity of WARDFlex CSST in Thousands of
BTU (KBTU) for Propane Gas (LPG)

Table A-9									
Gas Pressure of: 0.5 psi or Less									
Pressure Drop of: 0.5 inches W.C.									
<i>(based on a 1.52 specific gravity gas)</i>									
Size	10A 3/8"	15A 1/2"	20A 3/4"	25A 1"	31 1-1/4"	39 1-1/2"	48 1-1/2"	50A 2"	62
EHD	15	19	25	31	39	48	62		
5	100	245	426	785	1817	3425	6311		
10	70	164	303	564	1312	2440	4552		
15	57	131	248	464	1084	2002	3760		
20	49	110	216	404	948	1740	3283		
25	43	98	192	363	853	1560	2956		
30	40	88	177	335	784	1427	2712		
40	33	74	153	292	684	1239	2367		
50	30	66	137	263	616	1111	2130		
60	27	61	126	241	565	1016	1955		
70	25	56	116	226	526	943	1819		
80	24	52	109	211	494	883	1707		
90	22	49	102	200	467	834	1615		
100	21	47	98	191	444	791	1536		
125	19	42	90	172	399	714	1383		
150	16	37	83	158	368	662	1269		
200	14	33	74	139	320	588	1108		
250	13	30	67	124	289	535	997		
300	11	26	63	115	267	496	915		
400	9	23	56	99	233	441	799		
500	8	20	52	90	211	401	719		
600	8	18	49	82	194	373	660		
700	6	17	45	77	181	349	613		
800	6	15	42	72	170	330	576		
900	6	15	41	67	161	314	545		
1000	6	14	39	64	153	300	518		
1100	5	14	37	63	147	289	496		
1200	5	12	36	60	142	279	475		
1300	5	12	36	58	135	270	458		
1400	5	12	34	55	132	262	442		
1500	5	11	33	53	128	254	428		

Table includes losses for four 90 degree bends and 2 end fittings. To compute flow capacity for tubing runs with a larger number of bends and/or fittings, add the appropriate number of feet to the actual run length using the following formula:
 $L = 1.3(n)$ L = Numbers of feet to be added to actual run length
 n = Number of bends and/or fittings over six.

Maximum Capacity of WARDFlex CSST in Thousands of BTU
(KBTU) for Propane Gas (LPG)

Table A-10									
Gas Pressure of: 0.5 psi or Less									
Pressure Drop of: 1.0 inches W.C.									
<i>(based on a 1.52 specific gravity gas)</i>									
Size	10A 3/8"	15A 1/2"	20A 3/4"	25A 1"	31 1-1/4"	39 1-1/2"	48 1-1/2"	50A 2"	62
EHD	15	19	25	31	39	48	62		
5	142	304	599	1094	2518	4805	8752		
10	100	213	427	786	1818	3425	6312		
15	81	173	350	647	1503	2810	5214		
20	70	150	304	564	1313	2441	4553		
25	62	134	272	507	1182	2189	4098		
30	57	122	249	465	1085	2003	3761		
40	49	106	216	405	948	1740	3284		
50	43	95	194	364	854	1560	2956		
60	40	87	177	334	784	1427	2712		
70	36	80	164	310	729	1324	2522		
80	33	75	154	291	685	1240	2368		
90	32	71	145	275	648	1171	2240		
100	30	67	138	261	616	1112	2132		
125	27	60	124	235	555	997	1919		
150	24	55	113	215	510	912	1761		
200	21	47	98	187	445	792	1538		
250	19	42	88	168	401	711	1384		
300	16	39	81	154	368	650	1270		
400	14	33	70	134	321	565	1109		
500	13	30	63	121	289	506	998		
600	11	27	58	111	266	463	916		
700	11	25	54	103	247	430	852		
800	9	24	50	96	232	402	800		
900	9	22	47	91	219	380	756		
1000	8	21	45	87	209	361	720		
1100	8	20	43	83	200	344	688		
1200	8	19	41	79	192	330	660		
1300	8	18	40	76	185	317	636		
1400	6	18	38	74	178	306	614		
1500	6	17	37	71	173	296	594		

Table includes losses for four 90 degree bends and 2 end fittings. To compute flow capacity for tubing runs with a larger number of bends and/or fittings, add the appropriate number of feet to the actual run length using the following formula:
 $L = 1.3(n)$ L = Numbers of feet to be added to actual run length
 n = Number of bends and/or fittings over six.

Maximum Capacity of WARDFlex CSST in Thousands of BTU (KBTU) for Propane Gas (LPG)

Table A-11

Gas Pressure of: 0.5 psi or Less
Pressure Drop of: 3.0 inches W.C.
(based on a 1.52 specific gravity gas)

Size	10A	15A	20A	25A	32A	38A	50A
	3/8"	1/2"	3/4"	1"	1-1/4"	1-1/2"	2"
EHD	15	19	25	31	39	48	62
5	253	531	1025	2187	4217	8218	14689
10	177	373	730	1512	3044	5856	10595
15	142	303	599	1218	2516	4805	8751
20	123	262	520	1046	2198	4174	7641
25	109	233	466	929	1980	3743	6879
30	100	213	426	842	1817	3425	6311
40	85	186	369	723	1588	2974	5512
50	76	167	331	641	1430	2668	4961
60	70	153	303	583	1312	2440	4552
70	65	142	281	537	1220	2263	4233
80	60	134	263	499	1146	2121	3975
90	57	126	248	469	1090	2002	3760
100	54	120	235	444	1043	1901	3578
125	47	109	211	396	950	1705	3221
150	43	99	192	363	880	1560	2956
200	36	86	167	316	779	1354	2581
250	33	79	150	284	709	1215	2323
300	30	71	137	260	657	1111	2130
400	25	63	120	227	583	972	1860
500	22	56	107	203	531	877	1675
600	21	52	98	186	491	806	1536
700	19	47	90	173	459	750	1429
800	17	45	85	162	434	705	1342
900	16	42	80	153	414	668	1269
1000	16	41	75	147	396	637	1207
1100	14	39	72	140	380	608	1155
1200	14	37	69	134	366	584	1108
1300	14	36	67	129	354	564	1067
1400	13	34	64	124	344	545	1030
1500	13	33	63	120	333	527	997

Tubing Length (Ft.)

Table A-12

Gas Pressure of: 0.5 psi or Less
Pressure Drop of: 6.0 inches W.C.
(based on a 1.52 specific gravity gas)

Size	10A	15A	20A	25A	32A	38A	50A
	3/8"	1/2"	3/4"	1"	1-1/4"	1-1/2"	2"
EHD	15	19	25	31	39	48	62
5	362	757	1440	2666	5839	11530	20535
10	253	531	1025	1868	4217	8218	14689
15	205	431	840	1523	3485	6741	12133
20	177	373	730	1327	3044	5856	10595
25	156	333	654	1193	2742	5252	9536
30	142	303	599	1093	2516	4805	8751
40	123	262	520	953	2198	4174	7641
50	109	233	466	856	1980	3743	6879
60	100	213	426	785	1817	3425	6311
70	92	199	395	730	1691	3175	5869
80	85	186	369	684	1588	3000	5512
90	81	175	349	646	1503	2862	5213
100	76	167	331	614	1430	2744	4961
125	68	150	297	553	1297	2510	4465
150	62	137	271	507	1206	2333	4097
200	54	118	235	441	1074	2080	3578
250	47	107	211	396	983	1901	3221
300	43	98	192	363	913	1768	2956
400	36	85	167	316	814	1576	2581
500	33	75	150	284	744	1441	2323
600	30	69	137	260	692	1340	2130
700	27	64	128	243	651	1259	1982
800	25	60	120	227	616	1193	1860
900	24	56	112	216	588	1139	1760
1000	22	53	107	205	564	1092	1675
1100	22	52	102	196	543	1051	1601
1200	21	49	98	188	524	1014	1536
1300	19	47	94	181	507	983	1479
1400	19	45	90	175	493	954	1429
1500	19	44	88	170	480	927	1383

Tubing Length (Ft.)

Table includes losses for four 90 degree bends and 2 end fittings. To compute flow capacity for tubing runs with a larger number of bends and/or fittings, add the appropriate number of feet to the actual run length using the following formula:

$$L = 1.3 (n) \quad L = \text{Numbers of feet to be added to actual run length. } n = \text{Number of bends and/or fittings over six.}$$

7.4 PROPANE GAS - ELEVATED PRESSURE Maximum Capacity of WARDFlex CSST in Thousands of BTU (KBTU) for Propane Gas (LPG)



Table A-13

Gas Pressure of: 2.0 psi
Pressure Drop of: 1.0 psi

(based on a 1.52 specific gravity gas)

Size	10A	15A	20A	25A	32A	38A	50A
	3/8"	1/2"	3/4"	1"	1-1/4"	1-1/2"	2"
EHD	15	19	25	31	39	48	62
5	798	1650	3044	5846	11980	24352	43244
10	558	1159	2169	4097	8652	17358	30866
15	452	943	1779	3328	7152	14239	25340
20	390	815	1545	2871	6249	12373	22031
25	348	727	1385	2561	5627	11095	19764
30	316	663	1267	2332	5166	10150	18087
40	272	572	1101	2012	4513	8819	15725
50	243	511	987	1795	4064	7908	14155
60	221	466	903	1634	3731	7234	12989
70	204	430	837	1517	3470	6710	12079
80	190	402	784	1423	3259	6286	11342
90	179	379	740	1345	3084	5935	10729
100	169	359	703	1279	2935	5637	10210
125	150	320	630	1150	2643	5055	9190
150	138	292	576	1054	2426	4624	8433
200	119	252	501	918	2120	4018	7364
250	106	225	449	826	1909	3603	6629
300	96	205	411	757	1752	3296	6083
400	82	177	357	659	1531	2864	5311
500	73	158	320	593	1378	2568	4781
600	66	144	292	543	1265	2349	4387
700	62	133	271	505	1177	2179	4080
800	57	125	254	473	1105	2041	3831
900	54	118	240	448	1046	1927	3624
1000	51	112	228	426	995	1830	3448
1100	49	106	217	407	952	1747	3297
1200	46	102	208	390	914	1674	3164
1300	44	98	200	375	880	1610	3047
1400	43	94	193	362	850	1553	2942
1500	41	91	187	351	823	1501	2848

Tubing Length (Ft.)

Table A-14

Gas Pressure of: 5.0 psi
Pressure Drop of: 3.5 psi

(based on a 1.52 specific gravity gas)

Size	10A	15A	20A	25A	32A	38A	50A
	3/8"	1/2"	3/4"	1"	1-1/4"	1-1/2"	2"
EHD	15	19	25	31	39	48	62
5	1525	3121	5618	11112	21804	44902	79543
10	1067	2194	4002	7788	15616	32007	56775
15	865	1784	3281	6326	12878	26256	46611
20	746	1541	2851	5458	11251	22813	40524
25	664	1375	2556	4868	10132	20458	36355
30	604	1253	2337	4434	9301	18714	33268
40	522	1082	2031	3825	8221	16261	28924
50	465	965	1821	3411	7473	14582	25965
60	422	880	1666	3107	6914	13339	24025
70	390	814	1544	2870	6473	12443	22498
80	364	760	1446	2680	6114	11775	21254
90	343	716	1365	2524	5815	11213	20213
100	324	679	1297	2398	5559	10734	19326
125	289	605	1163	2149	5053	9788	17573
150	262	551	1063	1966	4675	9076	16261
200	226	478	924	1707	4135	8057	14384
250	202	429	834	1531	3759	7345	13080
300	183	393	768	1400	3477	6811	12102
400	158	341	673	1217	3074	6046	10706
500	141	306	608	1090	2796	5513	9735
600	128	281	559	997	2586	5112	9008
700	119	260	521	924	2421	4796	8436
800	111	243	491	866	2287	4538	7968
900	104	230	466	818	2175	4321	7579
1000	98	219	444	777	2078	4138	7246
1100	93	208	425	741	1996	3977	6958
1200	89	200	409	711	1923	3836	6705
1300	85	192	393	682	1858	3711	6479
1400	82	186	380	659	1800	3599	6278
1500	79	180	369	637	1748	3498	6096

Tubing Length (Ft.)

Table includes losses for four 90 degree bends and 2 end fittings. To compute flow capacity for tubing runs with a larger number of bends and/or fittings, add the appropriate number of feet to the actual run length using the following formula:

L = 1.3 (n) L = Numbers of feet to be added to actual run length. n = Number of bends and/or fittings over six.

Maximum Capacity of WARDflex CSST in Thousands of BTU (KBTU) for Propane Gas (LPG)

Table A-15

Gas Pressure of: 10.0 psi
Pressure Drop of: 7.0 psi
(based on a 1.52 specific gravity gas)

Size	10A	15A	20A	25A	32A	38A	50A
	3/8"	1/2"	3/4"	1"	1-1/4"	1-1/2"	2"
EHD	15	19	25	31	39	48	62
5		4569	7655	15886	31282	60175	94157
10		3235	5615	11327	23155	44728	71754
15		2644	4684	9293	19419	37602	61209
20		2291	4119	8076	17140	33245	54682
25		2050	3728	7243	15558	30217	50102
30		1872	3436	6626	14374	27949	46646
40		1622	3021	5758	12687	24711	41671
50		1451	2735	5164	11516	22460	38181
60		1325	2521	4724	10640	20774	35547
70		1227	2353	4382	9951	19448	33463
80		1148	2216	4106	9391	18367	31756
90		1083	2103	3876	8923	17464	30324
100		1028	2006	3682	8524	16694	29097
125		919	1815	3302	7737	15174	26660
150		840	1673	3021	7148	14035	24821
200		727	1471	2625	6309	12409	22174
250		651	1332	2354	5727	11278	20316
300		594	1227	2154	5291	10432	18915
400		515	1079	1872	4670	9223	16898
500		461	977	1678	4239	8383	15482
600		421	900	1536	3916	7754	14414
700		390	840	1424	3663	7259	13569
800		364	792	1334	3457	6855	12877
900		344	751	1260	3284	6518	12296
1000		326	716	1197	3138	6231	11799
1100		311	686	1142	3010	5982	11366
1200		298	660	1095	2899	5763	10985
1300		286	637	1053	2800	5569	10645
1400		276	616	1015	2711	5395	10341
1500		266	597	982	2631	5238	10065

Tubing Length (ft.)

Table A-16

Gas Pressure of: 25.0 psi
Pressure Drop of: 10.0 psi
(based on a 1.52 specific gravity gas)

Size	10A	15A	20A	25A	32A	38A	50A
	3/8"	1/2"	3/4"	1"	1-1/4"	1-1/2"	2"
EHD	15	19	25	31	39	48	62
5		7407	14503	24838	50546	69501	117452
10		5202	9729	17697	37079	54719	92856
15		4230	7702	14514	30932	47575	80931
20		3652	6526	12610	27200	43080	73411
25		3260	5739	11306	24618	39888	68063
30		2970	5167	10342	22691	37456	63983
40		2565	4378	8984	19953	33917	58038
50		2289	3850	8056	18058	31404	53809
60		2086	3466	7368	16645	29490	50584
70		1928	3171	6833	15537	27962	48009
80		1801	2936	6401	14636	26703	45884
90		1696	2744	6043	13886	25640	44088
100		1607	2582	5740	13247	24725	42541
125		1434	2271	5146	11989	22893	39442
150		1307	2044	4707	11051	21497	37078
200		1128	1732	4089	9717	19466	33632
250		1007	1523	3667	8795	18023	31182
300		917	1371	3354	8106	16925	29313
400		792	1162	2914	7128	15325	26589
500		707	1022	2612	6451	14190	24652
600		644	920	2390	5947	13325	23175
700		595	841	2216	5551	12635	21995
800		556	779	2076	5229	12066	21021
900		524	728	1960	4961	11585	20198
1000		496	685	1861	4732	11172	19490
1100		473	648	1776	4535	10810	18870
1200		452	617	1702	4362	10491	18321
1300		434	589	1637	4209	10205	17831
1400		418	564	1579	4072	9947	17389
1500		403	542	1526	3948	9713	16987

Tubing Length (ft.)

Table includes losses for four 90 degree bends and 2 end fittings. To compute flow capacity for tubing runs with a larger number of bends and/or fittings, add the appropriate number of feet to the actual run length using the following formula:

$L = 1.3(n)$ L = Numbers of feet to be added to actual run length. n = Number of bends and/or fittings over six.

7.5 STEEL PIPE CAPACITIES

Maximum Capacity of steel pipe in Cubic Feet per Hour (CFH) of Natural Gas
(Approximately 1000 BTU per cubic foot)

Table A-17

Gas Pressure of: **0.5** psi or Less
Pressure Drop of: **0.5** inches W.C.

(based on a 0.60 specific gravity gas)

	Size	1/2	3/4	1	1-1/4	1-1/2	2	2-1/2	3	3-1/2	4
Tubing Length (Ft.)	10	173	361	682	1,401	2,099	4,045	6,449	11,406	16,704	23,275
	20	118	248	468	963	1,443	2,781	4,433	7,841	11,483	16,000
	30	95	199	376	773	1,159	2,233	3,561	6,297	9,222	12,850
	40	81	171	322	662	992	1,911	3,048	5,390	7,894	10,999
	50	72	151	285	586	879	1,694	2,701	4,777	6,997	9,749
	60	65	137	258	531	796	1,535	2,448	4,329	6,340	8,834
	70	60	126	238	489	733	1,412	2,252	3,983	5,833	8,127
	80	56	117	221	455	682	1,314	2,095	3,705	5,426	7,561
	90	52	110	207	427	640	1,233	1,966	3,476	5,092	7,095
	100	49	104	196	403	604	1,164	1,857	3,284	4,810	6,702
	125	44	92	174	357	535	1,032	1,646	2,911	4,263	5,940
	150	40	83	157	324	485	935	1,491	2,637	3,863	5,382
	175	36	77	145	298	446	860	1,372	2,426	3,554	4,952
200	34	71	135	277	415	800	1,276	2,257	3,306	4,607	

Maximum Capacity of steel pipe in Thousands of BTU (KBTU) of Propane Gas (LPG)
(Approximately 2500 BTU per cubic foot)

Table A-18

Gas Pressure of: **0.5** psi or Less
Pressure Drop of: **1.0** inches W.C.

(based on a 1.52 specific gravity gas)

	Size	1/2	3/4	1	1-1/4	1-1/2	2	2-1/2	3	3-1/2	4
Tubing Length (Ft.)	5	618	1,295	2,440	5,012	7,512	14,477	23,082	40,821	59,782	83,300
	10	423	889	1,676	3,446	5,164	9,953	15,866	28,062	41,097	57,265
	15	341	715	1,347	2,766	4,148	7,993	12,744	22,537	33,007	45,990
	20	291	610	1,153	2,368	3,551	6,840	10,909	19,290	28,252	39,364
	25	259	540	1,021	2,099	3,147	6,063	9,669	17,099	25,039	34,892
	30	234	491	926	1,902	2,851	5,493	8,760	15,493	22,689	31,616
	40	199	421	792	1,628	2,440	4,704	7,497	13,262	19,422	27,061
	50	177	371	702	1,442	2,164	4,168	6,646	11,753	17,213	23,986
	60	159	336	635	1,307	1,960	3,777	6,021	10,650	15,597	21,733
	70	147	309	585	1,203	1,803	3,474	5,540	9,798	14,350	19,995
	80	137	289	543	1,118	1,678	3,232	5,154	9,116	13,351	18,603
	90	129	271	510	1,048	1,574	3,033	4,836	8,553	12,527	17,455
	100	122	254	483	991	1,487	2,866	4,569	8,080	11,832	16,489
125	107	227	428	879	1,317	2,540	4,049	7,161	10,488	14,614	

8.0 DEFINITIONS

8.1 DEFINITION OF TERMINOLOGY IN THIS GUIDE

AGA - American Gas Association

ANSI - American National Standards Institute

ANSI LC 1/CSA 6.26 - Fuel Gas Piping Systems Using Corrugated Stainless Steel Tubing (CSST)

ANSI Z223.1 - Edition of the National Fuel Gas Code published by American National Standards Institute. Also known as NFPA 54 (National Fire Protection Association - pamphlet 54).

ASTM - American Society for Testing and Materials

Appliance - Any device which utilizes gas as a fuel or raw material to produce light, heat, power, refrigeration or air conditioning.

ASME - American Society of Mechanical Engineers

Authority Having Jurisdiction - The organization, office or individual responsible for approving equipment, installations, or procedures.

BTU - Abbreviation for British Thermal Unit, which is the quantity of heat required to raise the temperature of one pound of water one degree Fahrenheit.

CFH - Gas flow rate stated in cubic feet per hour. A CFH of natural gas typically contains 1000 BTU's and LPG typically contains 2500 BTU's.

CGA - Canadian Gas Association

CAN/CGA - B149.1 - Natural Gas Installation code - most current edition

CAN/CGA - B149.2 - Propane Installation code - most current edition

CSA - Canadian Standards Association

CSST - Corrugated stainless steel tubing.

Delivery Pressure - Gas pressure available after the gas meter.

Design Pressure - The maximum permitted operating pressure.

Drip Leg - The container (dirt trap pocket) placed at the lowest point in a system of piping to collect foreign materials and condensate. The container must be accessible for cleanout.

EHD - Equivalent Hydraulic Diameter. A measure of the relative hydraulic efficiency between different tubing sizes. The larger the value of EHD, the greater the flow capacity.

Elevated Pressure System - Term for any pressure above 1/2 PSIG, but less than 5 PSIG.

Full Lockup Regulator - Specifically designed regulator capable of stopping gas flow if the load goes to zero, thus, preventing the downstream from increasing more than 2"(in.) WC pressure above the set point.

Joint - A connection between two lengths of tubing or a length of tubing and fitting.

Joint Compound - Non-hardening material used on pipe threads to ensure a seal.

Load - The amount of gas required by an appliance, or group of appliances, per their manufacturers rating. (See definition of CFH)

Manifold - A fitting to which a number of branch lines are connected.

Meter - An instrument installed to measure the volume of gas delivered through a piping system.

NFPA - National Fire Protection Agency

Piping - As used in this guide, either pipe or tubing or both.

A. Pipe - Rigid conduit of iron, steel, copper, brass or aluminum.

B. Tubing - Semirigid conduit of corrugated stainless steel (CSST).

Pressure - Unless otherwise stated, is expressed in pounds per square inch above atmospheric pressure, i.e., gauge pressure (PSIG).

Pressure Drop - The loss in gas pressure due to friction or obstruction in tubing, valves, fittings, regulators and burners.

Pressure Regulator - A valve which reduces and maintains pressure. It automatically opens and closes in response to changing pressure conditions in the downstream piping.

PSIG - Pounds per square inch, gauge. The pressure as read from a measurement gauge or device. Gauge pressure is pressure above atmospheric pressure and is sometimes simply referred to as PSI.

Purge - To completely displace an existing gas with a new gas.

Regulator, Gas Appliance Pressure - A device for controlling and maintaining a uniform pressure to the manifold of gas burning equipment.

Regulator, Line Gas Pressure - A device installed between the service pressure regulator and the gas appliance regulator for controlling, maintaining or reducing the pressure in that portion of the piping system downstream of the device. This device is used in elevated pressure systems and is simply referred to as a pressure regulator in this guide.

Regulator, Service Pressure - A device installed by the serving gas supplier to reduce and limit the service line gas pressure to delivery pressure.

Regulator Vent - The opening in the atmospheric side of the regulator housing, permitting the in and out movement of air to compensate for the movement of the regulator diaphragm.

Specific Gravity - Applied to a gas it is the ratio of the weight of a given volume to that of the same volume of air, both measured under the same conditions.

Tubing - ASTM A240 Type 304 annular corrugated stainless steel tubing, which is bendable and comes in 26, 50, 100, 180, 250, 500 and 1,000 foot coils depending on the diameter.

Valve - A device used to shut-off gas flow to the system.

Vent Limiting Device - A valve that limits the discharge of gas from a regulator in the event of a diaphragm rupture. Gas discharge is limited to an ANSI approved level.

Water Column, Inches (in. WC) - A method of stating pressure measured in inches of water column by a manometer or pressure gauge. Commonly used in the gas industry when the pressure is less than 1 PSIG. Approximate conversion between PSIG and in. WC:

1 PSIG = 2.8 in. WC

1/2 PSIG = 14 in. WC

1/4 PSIG = 7 in. WC

WARDFlex®

WARDFlex^{MAX}

WARRANTY

WARDFLEX®/WARDFLEX® MAX Gas Piping System

Ward Manufacturing, LLC (“SELLER”) warrants that its WARDFLEX® and WARDFLEX® MAX Gas Piping System products (“Product” or “Products”) will conform to SELLER’S applicable specifications and will be free from defects in materials and workmanship. The exclusive and sole remedy for any claim shall be a refund of the amount of the purchase price paid for the Product in respect of which damages are claimed, and in no event shall SELLER’S liability for any claim be greater than that amount. No charge for labor or expense required to repair defective goods will be allowed. EXCEPT AS EXPRESSLY PROVIDED HEREIN, SELLER MAKES NO EXPRESS OR IMPLIED WARRANTY, INCLUDING, WITHOUT LIMITATION, WARRANTIES OF MERCHANTABILITY OR FITNESS FOR A PARTICULAR PURPOSE.

This warranty shall not apply to any products that are not installed in accordance with the applicable WARDFLEX®/WARDFLEX® MAX Design and Installation Guide, or that are altered, repaired or misused, through negligence or otherwise, in a manner that, in the reasonable opinion of SELLER, adversely affects the reliability or performance of the Product. Nor does this warranty cover replacements or repairs necessitated by loss or damage resulting from any cause beyond the reasonable control of SELLER, including, but not limited to, acts of God, acts of government, acts of war, floods or fire.

This warranty shall begin upon the original date of occupancy of a new building in which the Product is installed and shall extend for a period of two (2) years to the original owner, provided that the Product was installed by a qualified professional who is licensed to install gas piping and who has completed a WARDFLEX® training class.

For Product installations other than new construction, this warranty shall begin from date of purchase of the Product from the SELLER’S stocking distributor and shall extend for a period of two (2) years. If proof of purchase cannot be verified, the warranty will extend from the manufacturing date code listed on the installed Product(s) for a period of two (2) years.

The forgoing is in lieu of any other expressed, implied or statutory warranties, and SELLER neither assumes nor authorizes any person to assume for SELLER any other obligation or liability in connection with the sales of its Products. UNDER NO CIRCUMSTANCES SHALL SELLER BE LIABLE FOR ANY INDIRECT, SPECIAL OR CONSEQUENTIAL DAMAGES.

WARDMFG

117 GULICK STREET | BLOSSBURG, PA 16912 | PH: 800-248-1027 | FAX: 570-241-0100 | WWW.WARDMFG.COM

