

Installation Instructions

7171000E

Access Riser

for PRO370 and PRO380-Series

The Access Riser allows a PRO370 or 380 simplex ejector system to be installed up to 18 inches below grade in an outdoor installation.

The riser provides a convenient underground chamber for electrical and pipe connections to exit underground and out-of-sight. A green twist-lock cover is removed to provide access to plumbing connections, valves and the electrical junction box.

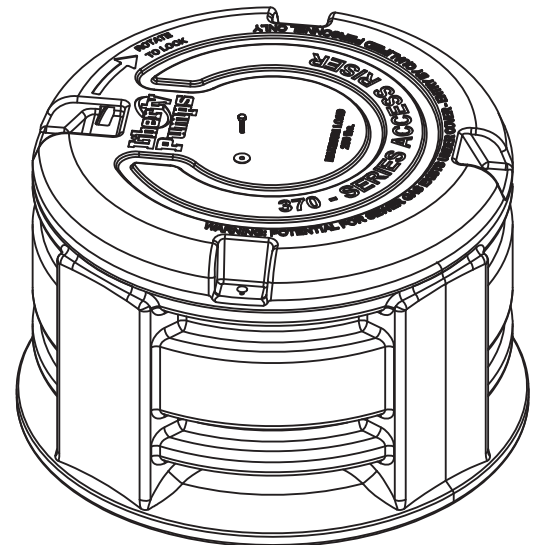

Important: *The Access Riser is not a gas or water-tight tank extension to increase the capacity of the basin.*

IMPORTANT: All Liberty Pumps products are supplied with their own separate Installation/Operation/Maintenance manuals. Ensure receipt of these manuals, and that they are read and understood prior to installation. For questions, call Liberty Pumps customer service at 1-800-543-2550.



7000 Apple Tree Avenue
Bergen, NY 14416
ph: 1-800-543-2550
fax: 1-585-494-1839
www.LibertyPumps.com

Keep this manual handy for future reference.

For replacement manual, visit LibertyPumps.com, or contact Liberty Pumps at 1-800-543-2550.

Retain dated sales receipt for warranty.

NOTICE

Installer: Manual must remain with owner or system operator/maintainer.

Record product information:

System: _____

Model: _____

Serial: _____

Mfg Date: _____

Install Date: _____

Contents

<i>Safety Precautions</i>	2 / EN
<i>Components and Available Kits</i>	2 / EN
<i>Typical Installation Diagram</i>	3 / EN
<i>Installation</i>	3 / EN
<i>Warranty</i>	4 / EN

Safety Precautions

⚠ WARNING **RISK OF FIRE**

- All installation and maintenance of pumps, controls, protection devices, and general wiring shall be done by qualified personnel.

Components and Available Kits

The riser is available by itself or as a kit with all the necessary components for a professional installation including elbows, electrical fittings and a junction box.

If only the riser was originally purchased, the 2" install kit will provide the necessary components to complete the installation.

Note: Due to size constraints, only 2" discharge installation kits are available. 3" discharge systems may require that some components be mounted outside of the riser.

Kit Number	Contents
AR18	Riser only
AC18	Cover only
ARC18	Riser and cover kit
IKIT2-115*	2" installation accessories, 115 Volt junction box (JB120)
IKIT2-230*	2" installation accessories, 230 Volt 1-phase junction box (JB230)
ARCKIT115	Complete kit ...ARC18, IKIT2-115, 115 Volt junction box (JB120)
ARCKIT230	Complete kit ...ARC18, IKIT2-230, 230 Volt junction box (JB230)

* Optional 2" Installation Kits (IKIT2-115 and IKIT2-230) include:

- Full flow 2" union-type check valve
- PVC ball valve
- (2) 90° PVC elbows
- (2) 2" rubber pipe seal grommets
- (2) Schedule 80 PVC toe nipple (threaded pipe)
- 2" rubber coupler with clamps

- Model JB120 or JB230 pump station junction (wiring) box with:
 - Terminal strip with separate alarm and pump control circuit
 - Receptacle for pump (115 Volt or 230 Volt, depending on model)
 - Riser extension coupling and washers
 - Custom-engineered liquid tight cable seal for pump, switch and alarm cords
 - Electrical conduit hub

Note: Installation kits do not include Schedule 40 PVC pipe.



JB120 or 230 Pump Station Junction (Wiring) Box (NEMA 4X)

Junction Box Template

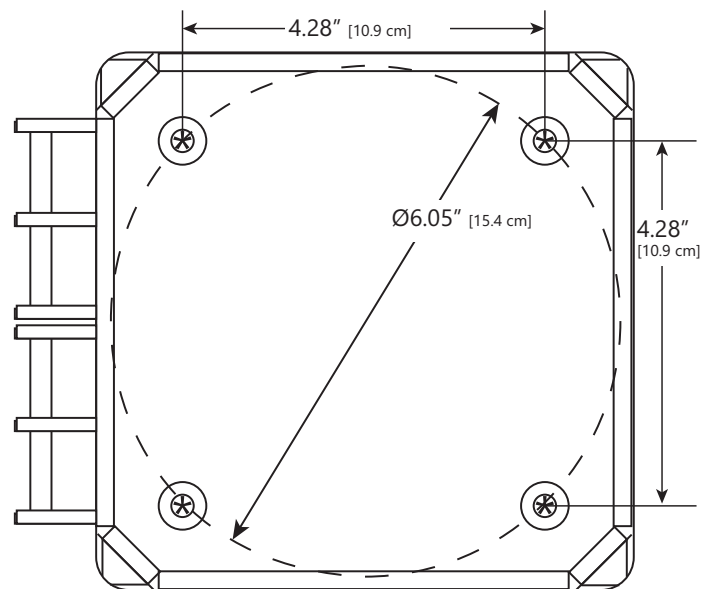

Typical Installation Diagram

PRO380 shown with installation components from IKIT2-115/ IKIT2-230.

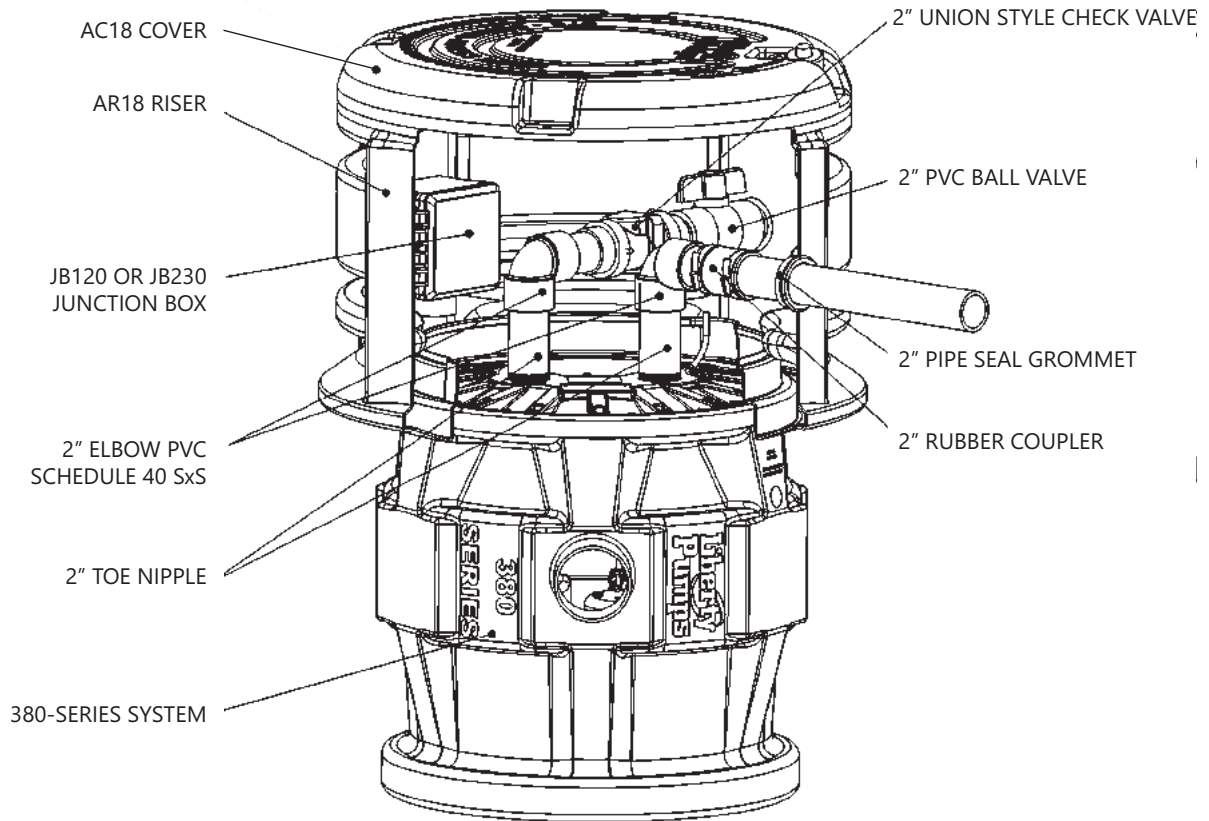

Installation

The installation instructions that follow include those components included in the optionally available kits.

1. PRO370 or PRO380-Series sewage system installation

Determine the overall height of the system and riser when excavating and setting the basin. The cover of the access riser should be at ground level when backfilling is complete. Burial depth of the system should not exceed 18" below finished grade.

Determine the discharge, electrical, and vent positions relative to the system. The access riser slides over the PRO370/380 tank and can be rotated in any direction to simplify plumbing. The riser will rest on the concrete splash lip of the basin.

2. Sidewall pipe seal grommets installation

Once exit positions have been determined for both the vent and discharge, install a 2" pipe seal grommet by first drilling a 3" hole in the sidewall of the riser. The riser has four flat areas as well as a large ring that runs around the riser from which the discharge pipe or vent can exit.

If both a check and ball valve are required, the discharge needs to exit on the opposite side (reference the *Typical Installation Diagram*).

To ease installation of the pipe through the pipe seal grommet, grease the pipe or use liquid soap as a lubricant.

3. Discharge connection

Thread a short pipe into the discharge port of the PRO-Series cover and attach a 90° elbow. A check valve is required to prevent water from backflowing and filling the basin, except in northern climates where frost may be a concern and pipes exiting from the side of the system may be exposed to freezing conditions.

If this unit is installed in a frost zone, do *not* use a check valve. Substitute a union to facilitate cover removal and pump access. If a check valve is not used, the vertical lift should be minimized to reduce the amount of backflow after each cycle. A maximum length of 30' of 2" pipe can be pitched to drain back into the system. Beyond 30', discharge piping should be pitched down toward the final discharge destination.

A ball valve is recommended so that backflow can be prevented in the event the pump or check valve must be removed for service. When connecting the check valve, ball valve, etc., carefully position items as close to the sidewall of the riser as possible to allow room for removal of the system cover. Use unions and couplings as necessary to allow for this.

4. Vent connection

To maintain hidden pipes, the vent pipe can be routed underground to an existing household vent. For a 2" vent, a 3" hole should be drilled in the sidewall of the riser where the vent pipe is to exit.

Install the pipe seal grommet. The pipe should be lubricated with liquid soap or grease to ease pipe installation. Thread a 90° elbow with male threads into the vent flange of the system. A rubber slip coupler should be installed in the vent piping to allow easy removal of the system cover and pump if service is required.

5. Electrical connection

A NEMA 4X weatherproof pump station junction box (Liberty Pumps model JB120 or JB230) is recommended. It can be mounted inside or outside of the access riser.

If mounting inside, reference the included *Junction Box Template* to drill the four mounting holes. If nonmetallic conduit is used, it must be mounted at least 18" below grade. Consult the National Electrical Code (NEC) and local codes for further information. Additional instructions are included with the JB120 or JB230 box.

6. Backfilling

Use only fine, 1/8" to 3/4" pea gravel or 1/8" to 1/2" washed, crushed stone as backfill around the access riser. Do not use sand or native soil as backfill. Tamp backfill lightly. A light layer of topsoil can be used at cover level. *Avoid running heavy equipment next to the riser.*

7. Cover installation

The cover features a twist-lock design and 4 stainless steel screws to secure it. When installing the cover, line up the four tabs with the four receptacles and locking tongue which fits into a cut recess in the underside of the cover. Push down and rotate the cover in a clockwise direction until the tongue bottoms in the slot. Install the four stainless steel bolts to secure the cover. A padlock can be placed through a hole in the tongue to deter unwanted entry.

The cover is designed to handle light traffic loads such as walking or light lawn and garden equipment.

DO NOT RUN HEAVY TRACTORS OR OTHER EQUIPMENT OVER THE COVER. MAXIMUM LOAD RATING IS 250 LBS.

Warranty

Liberty Pumps Wholesale Products Limited Warranty

Liberty Pumps, Inc. warrants that Liberty Pumps wholesale products are free from all factory defects in material and workmanship for a period of three (3) years from the date of purchase (excluding* batteries and "Commercial Series" models). The date of purchase shall be determined by a dated sales receipt noting the model and serial number of the pump. The dated sales receipt must accompany the returned pump if the date of return is more than three years from the date of manufacture noted on the pump nameplate.

The manufacturer's sole obligation under this Warranty shall be limited to the repair or replacement of any parts found by the manufacturer to be defective, provided the part or assembly is returned freight prepaid to the manufacturer or its authorized service center, and provided that none of the following warranty-voiding characteristics are evident:

The manufacturer shall not be liable under this Warranty if the product has not been properly installed, operated, or maintained per manufacturer instructions; if it has been disassembled, modified, abused, or tampered with; if the electrical cord has been cut, damaged, or spliced; if the pump discharge has been reduced in size; if the pump has been used in water temperatures above the advertised rating; if the pump has been used in water containing sand, lime, cement, gravel, or other abrasives; if the product has been used to pump chemicals, grease, or hydrocarbons; if a non-submersible motor has been subjected to moisture; or if the label bearing the model and serial number has been removed.

Liberty Pumps, Inc. shall not be liable for any loss, damage, or expenses resulting from installation or use of its products, or for indirect, incidental, and consequential damages, including costs of removal, reinstallation or transportation.

There is no other express warranty. All implied warranties, including those of merchantability and fitness for a particular purpose, are limited to three years from the date of purchase. This Warranty contains the exclusive remedy of the purchaser, and, where permitted, liability for consequential or incidental damages under any and all warranties are excluded.

*Liberty Pumps, Inc. warrants StormCell® batteries for 1 year from date of purchase, and warrants that pumps of its Commercial Series are free from all factory defects in material and workmanship for a period of 18 months from the date of installation or 24 months from the date of manufacture, whichever occurs first, and provided that such products are used in compliance with their intended applications as set forth in the technical specifications and manuals.