



Product information presented here reflects conditions at time of publication. Consult factory regarding discrepancies or inconsistencies.

PUMP COMPANY

Zoeller Family of Water Solutions™

MAIL TO: P.O. BOX 16347 • Louisville, KY 40256-0347
SHIP TO: 3649 Cane Run Road • Louisville, KY 40211-1961
(502) 778-2731 • 1 (800) 928-PUMP • FAX (502) 774-3624

visit our web site:
www.zoeller.com

THE Basement Sentry®

Series by ZOELLER®

MODEL 507

12 VOLT DC BATTERY BACKUP PUMP

PREINSTALLATION CHECKLIST

1. Inspect your pump. Occasionally, products are damaged during shipment. If the unit or any of the parts are damaged, contact your dealer before using.
2. Read all the installation instructions regarding installing and start up. Retain for future reference.

P/N 009132



WARNING

SEE BELOW FOR LIST OF WARNINGS

1. Testing for Ground. As a safety measure each electrical outlet should be checked for ground using an Underwriters Laboratory listed circuit analyzer, which will indicate if the power, neutral and ground wires are correctly connected to your outlet. If they are not, call a qualified, licensed electrician.
2. For your protection always disconnect the power supply from its power source before handling the components of your DC backup pump or the primary pump.
3. Installation and checking of electrical circuits and hardware should be performed by a qualified, licensed electrician.
4. All electrical and safety codes must be followed in addition to the National Electrical Code and all applicable local codes.
5.  It is the owner's responsibility to check the battery and battery connection at least once a month. Batteries contain acid and caution must be taken when handling.
6. Risk of electric shock - These pumps have not been investigated for use in swimming pool areas.
7. According to the state of California (Prop 65), this product contains chemicals known to the state of California to cause cancer and birth defects or other reproductive harm.

CAUTION

SEE BELOW FOR LIST OF CAUTIONS

1. Make sure there is a properly grounded 115V receptacle available. Do not use primary pump circuit. The location must be within 6' of the control box and battery. The power supply for your DC control system plugs directly into the 115V outlet. **DO NOT USE AN EXTENSION CORD.**
2. Make sure the 115V electrical supply circuit is equipped with fuses or circuit breakers of proper capacity.
3. DC emergency pumps are designed for handling clear water. Do not use in septic tanks to pump effluent or sewage pits to pump sewage.
4. Repair and service of your DC backup system should be performed by an authorized service station.
5. The installation of DC automatic backup pumps requires the use of a variable level float switch for operation. It is the responsibility of the installing party, to ensure that the float switch will not hang up on the pump apparatus or pit peculiarities and is secured so the pump will turn "on" and "off". It is recommended that the pit be 18" in diameter or larger to accommodate both a primary and a DC backup pump.

CAUTION Turbulence caused by high velocity incoming water can cause the DC pump to airlock. If this condition exists, the incoming water must be baffled to avoid excessive turbulence.

REFER TO WARRANTY ON PAGE 2.

LIMITED WARRANTY

Manufacturer warrants, to the purchaser and subsequent owner during the warranty period, every new product to be free from defects in material and workmanship under normal use and service, when properly used and maintained, for a period of one year from date of purchase by the end user, or 18 months from date of original manufacture of the product, whichever comes first. Parts that fail within the warranty period, one year from date of purchase by the end user, or 18 months from the date of original manufacture of the product, whichever comes first, that inspections determine to be defective in material or workmanship, will be repaired, replaced or remanufactured at Manufacturer's option, provided however, that by so doing we will not be obligated to replace an entire assembly, the entire mechanism or the complete unit. No allowance will be made for shipping charges, damages, labor or other charges that may occur due to product failure, repair or replacement.

This warranty does not apply to and there shall be no warranty for any material or product that has been disassembled without prior approval of Manufacturer, subjected to misuse, misapplication, neglect, alteration, accident or uncontrollable act of nature; that has not been installed, operated or maintained in accordance with Manufacturer's installation instructions; that has been exposed to outside substances including but not limited to the following: sand, gravel, cement, mud, tar, hydrocarbons, hydrocarbon derivatives (oil,

gasoline, solvents, etc.), or other abrasive or corrosive substances, wash towels or feminine sanitary products, etc. in all pumping applications. The warranty set out in the paragraph above is in lieu of all other warranties expressed or implied; and we do not authorize any representative or other person to assume for us any other liability in connection with our products.

Contact Manufacturer at, 3649 Cane Run Road, Louisville, Kentucky 40211, Attention: Customer Support Department to obtain any needed repair or replacement of part(s) or additional information pertaining to our warranty.

MANUFACTURER EXPRESSLY DISCLAIMS LIABILITY FOR SPECIAL, CONSEQUENTIAL OR INCIDENTAL DAMAGES OR BREACH OF EXPRESSED OR IMPLIED WARRANTY; AND ANY IMPLIED WARRANTY OF FITNESS FOR A PARTICULAR PURPOSE AND OF MERCHANTABILITY SHALL BE LIMITED TO THE DURATION OF THE EXPRESSED WARRANTY.

Some states do not allow limitations on the duration of an implied warranty, so the above limitation may not apply to you. Some states do not allow the exclusion or limitation of incidental or consequential damages, so the above limitation or exclusion may not apply to you.

This warranty gives you specific legal rights and you may also have other rights which vary from state to state.

Note: The purchase of an Aquanot® Battery from Zoeller Pump Company will extend the Limited Warranty to three years from date of installation.

Note: Three year limited warranty valid only when a complete system is purchased and used as a backup to a primary dewatering system. A complete system includes a Model 507 Basement Sentry® and an Aquanot® Battery.

MAINTENANCE

- Inspect and test the system for proper operations at least every 3 months.*
 - Red power on indicator light should be "on" indicating AC power is on.
 - Unplug primary pump and the control charger from power supply.
 - Fill sump with water to the "on" level for the DC pump. Allow pump to run a few minutes.
 - The alarm will sound approximately 3 seconds after the pump starts to run.
 - Push alarm reset switch. The alarm will go "off".
 - Pump will shut off after water level is lowered and the float drops to the off position.
- Plug the control charger and the primary pump into the wall outlet.
 - The primary pump will come on and lower the water to the normal operating level and shut off.
 - The "yellow" charging light should be on. The charger is replacing the energy consumed during the test. The "green" light will come on after the charger has replaced the energy consumed during the test.

* Wet cell batteries should be checked every month.

TROUBLESHOOTING INFORMATION

- DC Pump won't run.
 - Check 15 amp fuse in line from pump to switch (see fig. 3). If fuse is blown, replace with 15 amp Littelfuse type 3AG, series 311.
 - Check for proper connections.
 - Check all wire terminal points. Clean if required.
 - Check for low battery. Service battery if required.
 - Pump runs but pumps very little or no water.
 - Check for low battery. Battery will recharge if Red power "on" light indicates power has been restored and the float switch is in the off position.
 - If immediate usage is required, remove and replace dead battery with a full recharged battery.
 - Due to varying conditions the pump may continue to run on a low battery without sufficient power to remove water. Pump will not stop running until battery is completely discharged.
 - CAUTION** Weak batteries can be recharged but may not store sufficient energy for full service. A weak recharged battery can only be detected by reduced pumping time or by checking each cell with a hydrometer. If your emergency pump system is used frequently the battery should be checked by a qualified battery dealer.
 - Pump cycles too frequently.
 - Check positions of rubber stops on float rod.
 - Adjust upper rubber float stop as required. Recommended for standard installation.
 - Float switch in "on" position. Pump won't run.
 - Check for obstruction in pump preventing impeller from rotating.
 - Pump runs, but pumps water intermittently.
 - Pump is air locking. Check flow of water incoming to sump. If water is entering the sump at a high velocity creating a turbulent condition, a mixture of air and water may cause a complete or partial air lock and reduce or stop the flow of water in the discharge pipe.
 - Baffle the incoming stream of water to reduce turbulence. Diverting water stream against wall of basin usually corrects an air lock problem.
- NOTE: When running the primary pump, it is normal for a stream of water to spray out of the 1/8" air relief hole.
- Water level stays high. DC Pump continues to run.
 - Battery is low.
 - If power has been restored and water in sump remains high check primary pump. Service if required.
 - After several hours the battery will be restored to full charge.

TROUBLESHOOTING INFORMATION, *continued*

7. Alarm sounds during battery recharge cycle.

(a) Push alarm reset (max. 3 times). If condition persists, replace battery.

(b) To silence alarm if alarm will not reset, unplug the charger from 115V wall outlet, then disconnect the black lead from charger on negative (-) battery post. Check battery. Replace if necessary. Reconnect and refer to Installation (step 12).

DESCRIPTION

The DC emergency pump is designed as a backup to your primary sump pump during unexpected power outages or primary pump failure. The DC pump, electronic controls and all the parts required for installation are included except the battery which is supplied by the user. The system is designed for installation in sumps with minimum of 18" diameter and 24" deep. For 18" x 22" applications, consult factory.

REPLACEMENT PARTS LIST

ITEM	DESCRIPTION	QTY	MODELS:			
			507-C	507-D	507-E	507-F
			4/96 thru 10/05	11/05 thru 9/11	10/11 thru 10/13	11/13 thru Current
1	DC backup pump	1	010475	017198	017198	017198
2	Plastic battery box and cover	1	10-0764	10-0764	10-0764	10-0764
3	DC control charger with terminals	1	152899	152899	152899	152899
4	"Off"/"On" float switch	1	017197	017197	017197	017197
5	1½" x 5" long PVC pipe nipple	1	005639	N/A	N/A	N/A
6	Check valve	(2) REV C - (1) REV D	005636	005636	019768	019768
7	Reducer hose coupling and clamp	1	30-0188	N/A	N/A	N/A
8	1¼" x 1" PVC reducer fitting	1	005642	N/A	N/A	N/A
9	1" pipe to hose adapter elbow	1	005643	N/A	N/A	N/A
10	1" hose coupling and two clamps	1	005703	N/A	N/A	N/A
11	1½" PVC pipe tee	1	005645	005645	005645	005645
12	1½" 90 degree PVC pipe elbow	1	005644	N/A	N/A	N/A
13	1¼" x 1¼" PVC coupling	1	009129	N/A	N/A	N/A
14	Pump mounting kit, includes brkt, S.S. worm drive clamp, two #10-24 screws and washers.	1	005704	N/A	N/A	N/A
15	Cable tie	1	005868	N/A	N/A	N/A
16	Anchors, wall	2	009691	009691	009691	N/A
17	Bracket, control mounting	1	007779	007779	007779	N/A
18	1½" x 1½" PVC coupling	1	N/A	009746	N/A	N/A
19	Clamp, H28 SS / zinc-plated screw	1	012724	012724	012724	012724
20	Fuse, AGC - 15 amp	1	N/A	012352	012352	012352

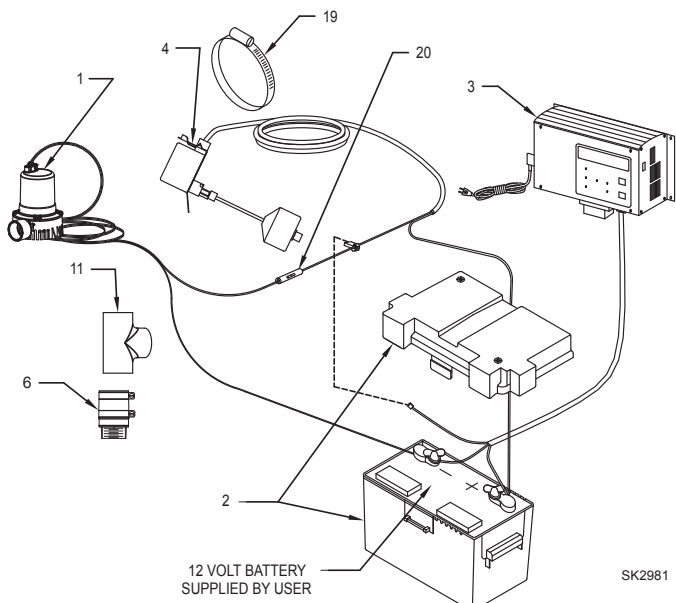

BATTERY SELECTION

The DC emergency pump system requires a good quality, 12 volt battery to obtain maximum pumping time during a power outage. A deep-cycle, 12 volt, 105 amp-hour marine battery or larger is recommended and will provide approximately 7½ hours of continuous pumping time in a sump pump installation with 8' of head pressure. In most installations the pump runs intermittently and the battery life is extended accordingly. Batteries with top terminals are recommended for ease of installation. These batteries contain acid and proper precaution must be taken when handling. Maximum battery size 13½" length x 7" width x 9½" height.

PERFORMANCE

The DC pump performance with fully charged 12V battery

Discharge: Feet of Head	5	10	15	17.5
Flow: Gal. per Min.	23	15	5	Shut-off Head

The DC controller is equipped with a 10 amp charger for maintaining the battery in a ready state and recharging the battery after use when AC power is restored. Time for recharge depends upon the amount of power consumed by the pumping cycle during the AC power interruption. The pump may go back to the ready run position in a very short period of time. A completely drained battery may require up to 24 hours for full recharge. If battery does not charge properly, the LCD will display BATFAIL and the alarm will sound.

INSTALLATION

1. The preferred method of installation for backup pumps is shown in Figures 1 and 2. The installation kit includes the necessary fittings and one check valve for installing with the backup pump discharging into the primary pump outlet pipe. An additional check valve is incorporated in the discharge of the backup pump.

NOTE: Do not install in small spaces where the charger will not be properly cooled.

2. Remove all parts from shipping carton and make sure all parts are included. Refer to checklist on page 3.
3. Select location for battery and control charger. Control charger must be within 6' of a 115V wall outlet and within 6' of pump and basin. Connect to a separate circuit, different than the primary pump.
4. If primary pump is installed, disconnect power.
NOTE: Discharge piping must be 1-1/2" SCH 40 PVC
5. Remove the discharge pipe from the pump and put to the side.
6. Solvent weld DC pump to tee at a **30 degree angle** as shown in Figure 4.
7. Install in-line check valve into primary pump discharge.
8. Determine the position of the DC pump and measure between the in-line check valve and tee. Use that measurement to cut discharge pipe. Solvent weld that piece first to the tee. Measure, cut & solvent weld any remaining discharge piping above the tee. Finally, connect the discharge pipe to the in-line check valve and tighten hose clamp. See Figure 4..

NOTE: Check float operations to ensure the hose clamp screws do not interfere with the float operation of the primary pump.

9. Assemble the float assembly per figure 5.
10. Install the float switch assembly bracket above the outlet tee using the clamp provided (see figures 1 and 2). Make certain the clamp is tight on the pipe to avoid slippage. Use electrical tape below the clamp to help prevent the clamp from moving. Ensure that the "off" level of the float is 1" min. above the discharge tee of the DC backup pump (see figures 1 and 2). Position pumps in the sump and move float up and down, making sure of free movement without interference from any obstructions inside the sump or lid. Very shallow sumps may require some adjustment to avoid overflowing or backing up of water into the sump inlet. The float switch can

be moved on the discharge pipe or the rubber stops can be adjusted as necessary. Cut extra float rod length below lower float stop to prevent debris from interfering with float operation.

11. Install DC charger (see figure 3) by using anchors provided. If more convenient, the charger may be set on a nearby shelf or ledge. The charger should be located 3 or 4 ft. above the sump. Then, remove protective screen from the front of the charger.
12. Connect the leads from the control charger to the battery terminals. Positive (+) lead to positive terminal and black neg. (-) lead to negative battery terminal. Upon proper connection, test alarm will momentarily sound. This indicates proper charger to battery connection.
CAUTION Correct battery hook up is essential for operation of the system. Use wing nuts supplied with battery and eyelet connectors on battery wire leads. The positive terminal is the larger stud, 3/8" diameter. The smaller stud, 5/16" diameter is the negative terminal. Apply grease to the terminals to help prevent corrosion.
13. Connect the black lead from the pump to the negative (-) battery terminal. Connect the white lead from the pump to the white lead from the switch. This connection is made at the fuse installed on the switch wire (see figure 3). Connect the black lead from the switch to the positive (+) battery terminal.
14. Connect the green sensor wire to the sensor connector (figure 3).
15. Close battery box and secure cover. Carpeted or wood barrier between the battery case and the floor is recommended.
16. Plug the charger's cord into charger and the 115V wall outlet. The primary sump pump and the control box should be on separate circuits.
17. Reconnect power to primary sump pump.
18. Optional: A dongle may be used to input a name and number into the charger for service information to the end user.
19. Optional: On the bottom of the charger there is a pair of dry contacts to signal an auxiliary device of a low battery, high water and reverse polarity alarm condition. This simple 2-wire connection is rated at a maximum of 24V AC/DC and 0.5 amps. It can be used with an auto-dialer (such as the Zoeller 10-2616), alarm or home security system. Read the auxiliary equipment's documents for further instructions.

INITIAL START-UP AND OPERATION

1. Test the installation for leaks by running water into the sump allowing for normal operation of the primary pump.
2. Check the control charger. The "red" power on light will be lit when the unit is plugged into the 115V wall outlet. The *charged/charging* lights will indicate the condition of the battery when the charger has AC power.
3. Disconnect primary pump before touching any component in the sump pit.
4. Lift float switch. The DC backup pump will run and the alarm will sound. Lower float switch immediately after alarm has sounded. Pump is running dry during initial check for several seconds. **CAUTION** Continuous dry running may cause overheating and damage the pump seals. Upon release of the float switch, the pump will shut off. Press the reset button to turn the alarm off.
5. Complete the final testing of your installation by ensuring the primary pump is still disconnected from the power. Then, unplug the charger from the

115V wall outlet. Run water into the sump until the DC backup pump is activated by the float switch. Check all connections for leaks.

NOTE: When running the primary pump, it is normal for a stream of water to spray out of the 1/8" air relief hole.

6. Push alarm reset switch when pump is running. This will silence the alarm. The pump will continue to run.
7. Reconnect the charger and your primary pump to the AC wall outlets. The primary pump should come on and lower the water level in the sump back to the normal operating level and shut off. Use the alarm reset button to reset the high water light. Both primary and backup systems are now ready for use.
8. The battery charged and charging LED's will alternate during normal charging operation.

NOTE: See page 7 for a description of charger functions.

ASSEMBLY WITH SUBMERSIBLE PUMP

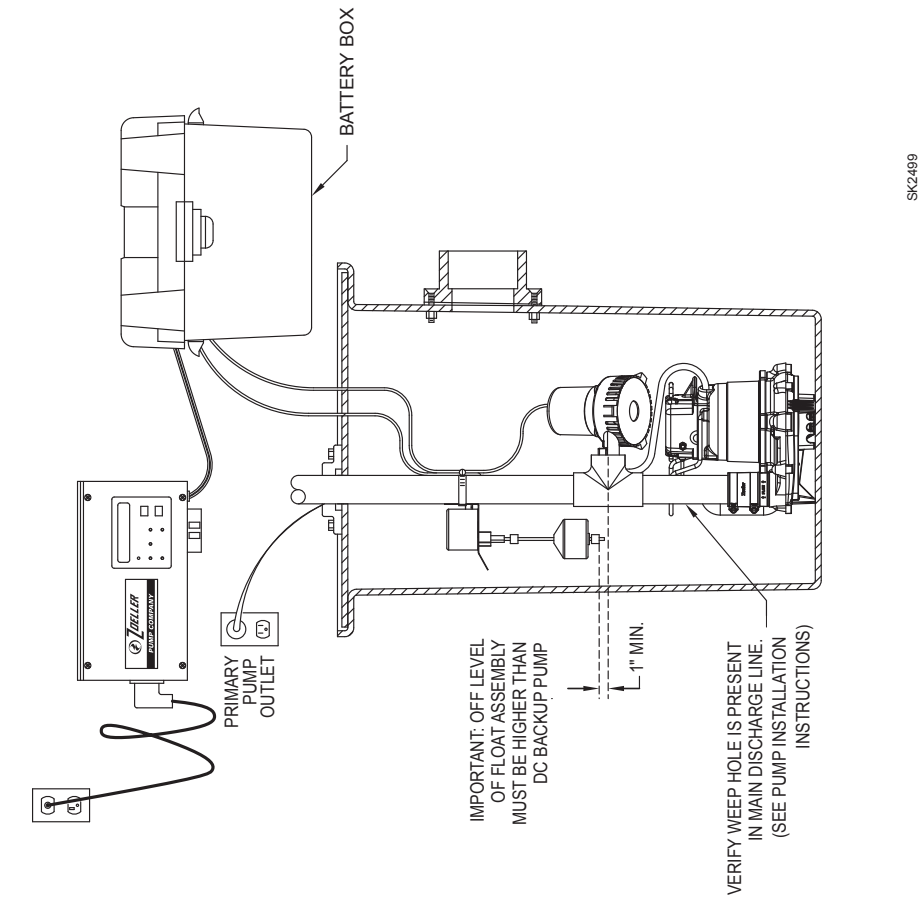

NOTE: Pump must be mounted on a 30° angle to avoid airlocking
NOTE: The section of pipe below the tee determines the height of the DC pump. A shorter piece of pipe may be beneficial in some installations. This drawing is dimensioned for clarity.

FIGURE 1

ASSEMBLY WITH COLUMN PUMP

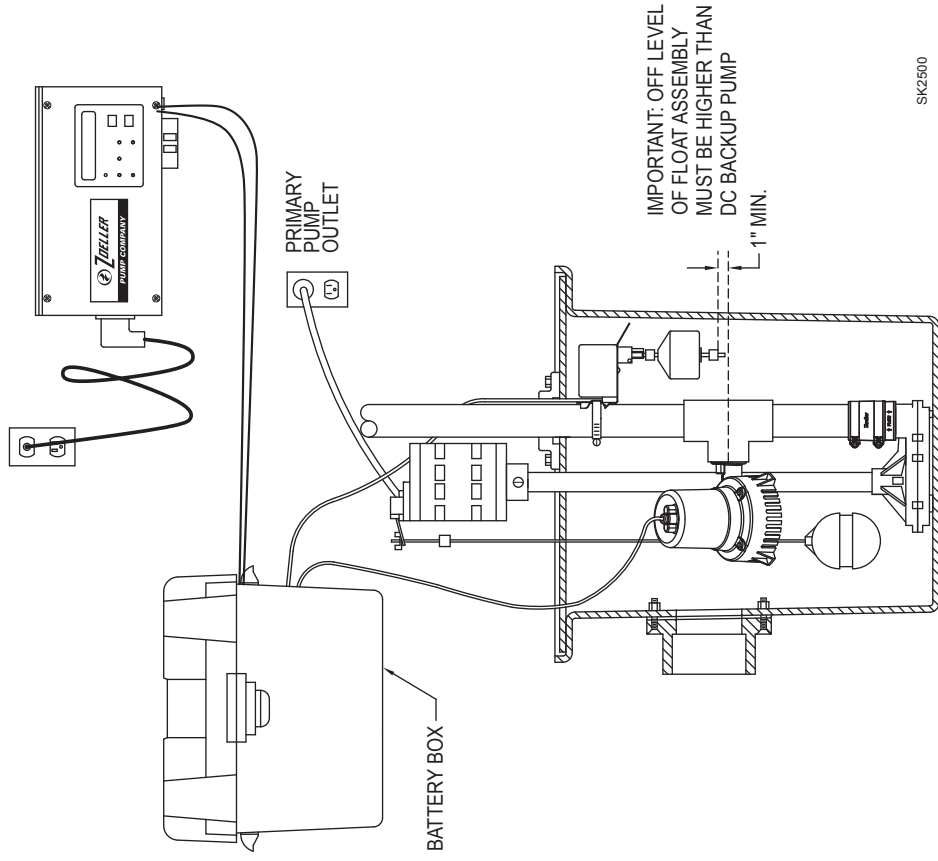

NOTE: Pump must be mounted on a 30° angle to avoid airlocking
NOTE: The section of pipe below the tee determines the height of the DC pump. A shorter piece of pipe may be beneficial in some installations. This drawing is dimensioned for clarity.

FIGURE 2

EXPLODED VIEW - DC PUMP

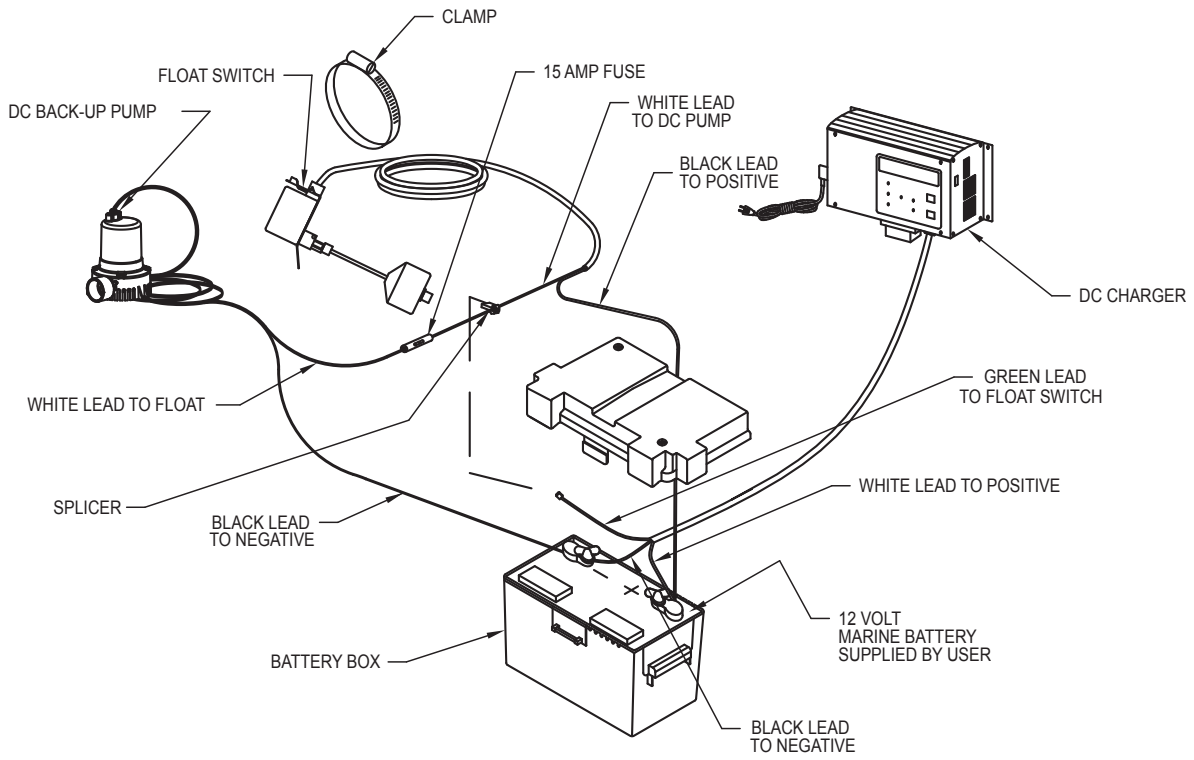

FIGURE 3

SK2501

PUMP ASSEMBLY

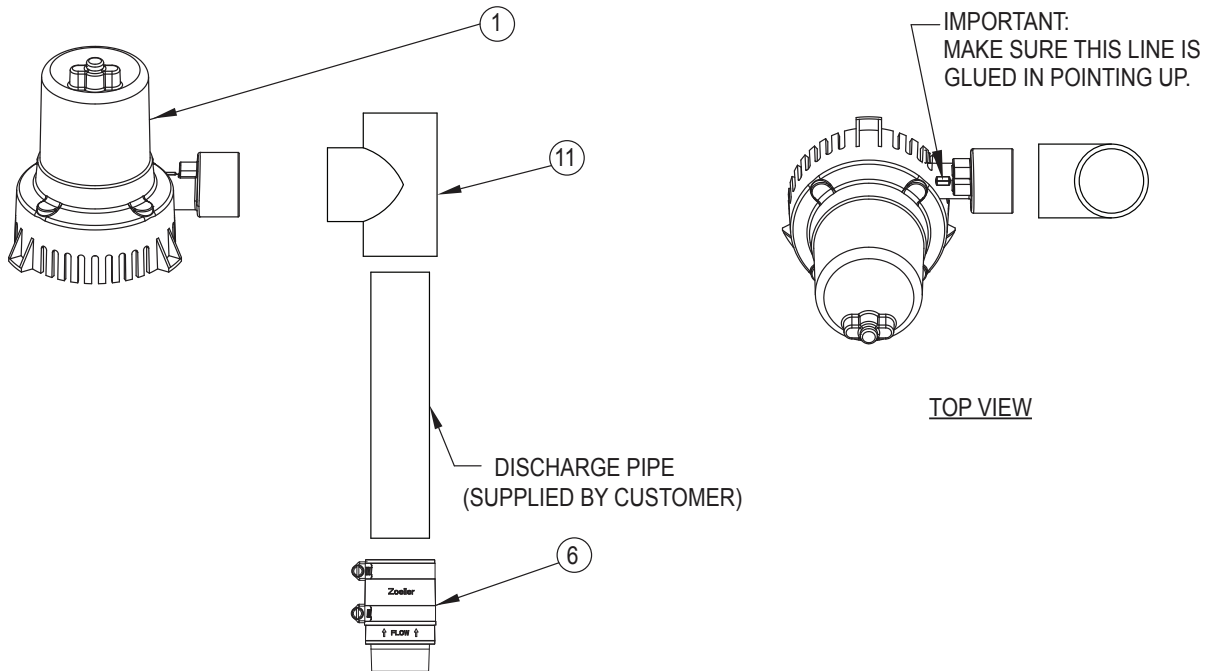

FIGURE 4

SK2502

FLOAT SWITCH

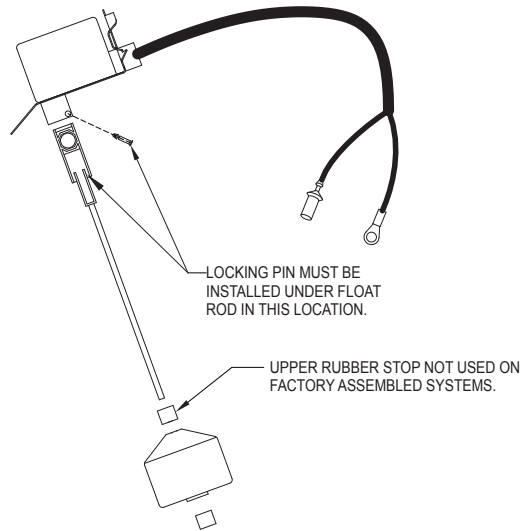

FIGURE 5

SK2503

CONTROL CHARGER

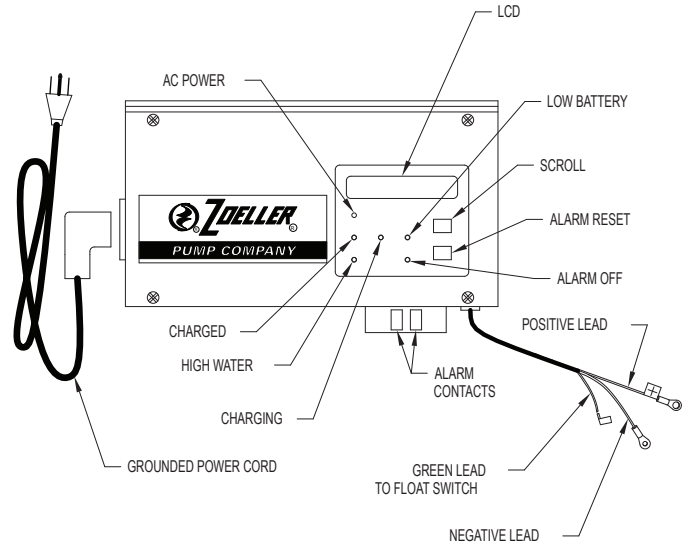

FIGURE 6

SK2958

LCD DISPLAY AND KEYPAD FUNCTIONS

There are two buttons on the front of the charger:

- The scroll button is used to cycle through the information on the LCD screen.
- The alarm reset button:
 - Can be pressed to clear alarm buzzer, light and/or display.
 - Can be held for longer than 3 seconds to silence the buzzer for a 24-hour period.

The LCD screen will display information about the system by simply hitting the scroll button:

- The bottom line of the LCD will always display the battery voltage and current going to the battery, if charging.
- The alarm screen shows current alarms.
- The cycle counter screen shows how many times the DC float has been activated.
- The AC power loss counter screen shows how many times the AC power has been removed from the charger.
- Optional: a screen may also show the name and number of a service provider.

The 6 LED lights also display information about the charger at a glance:

- The red *AC power* light will be on if AC power is connected, and it will blink if AC power is not connected.
- The green *charged* light indicates a full battery, ready for operation.
- The yellow *charging* light indicates power going to the battery.
- The red *low battery* light blinks when the battery is below 10.8 volts and rapidly blinks when the battery is below 8.4 volts.
- The yellow *high water* light will blink when the float is activated, and becomes solid after 3 seconds.

NOTE: The pump should be running when the float is activated.

- The yellow *alarm off* light indicates the buzzer is currently silenced.

THE AQUANOT® BATTERY

There are millions of batteries manufactured each year, so it is impossible to guarantee consistent quality. A defective battery will never become fully charged and may damage the charging circuits of the Control. It is for this reason that Zoeller offers its own line of batteries. We offer both a Water/Acid Deep-Cycle Battery and maintenance-free AGM battery which can run the pump continuously for over 7½ hours. These times are based on continuous pumping at 10' of static head. Actual times will vary depending on static head, volume of water entering the pit, and the condition of the battery.

Follow these recommendations:

- Use a B.C.I. size 27 deep-cycle battery, 175 minute reserve capacity, or larger.
- Do NOT use a "maintenance-free" battery unless it is a Gel-filled or AGM battery.
- Replace your battery every 3 years.
- Do not let corrosion build up on the battery terminals.
- To check specific gravity, follow the instructions on a hydrometer (not applicable for Gel or AGM batteries).

PROTECT YOUR WARRANTY:

- Water level in batteries must be checked once a month (not applicable for gel or AGM batteries).

CARBON MONOXIDE DETECTORS

Whether you have a "Basement Sentry®" Backup Pump System, or a competitive brand, all use batteries that give off gaseous by-products when charging. Some of these by-products can produce a rotten egg odor. Also, some of these by-products can cause a CO detector to falsely activate. In order to help prevent false activation, Zoeller Company recommends moving the battery as far apart from the CO detector as possible or, if necessary, vent the battery to the exterior. Zoeller Company provides the previous statements only as guidelines to help prevent false activation of the CO detector. In no way are they meant to supersede the instructions that accompany the detector nor do they supersede advice from the CO detector manufacturer.

If the audible alarm associated with your CO detector is activated, we recommend the following actions:

- 1) Take immediate action for personal safety as recommended in the CO detector literature.
- 2) Contact the appropriate agency to determine if the CO is being produced by your furnace, water heater, or any other device which uses natural gas.
- 3) If you are certain that no CO is being produced, then a charging battery may be producing gaseous by-products which are causing the CO detector to activate. Contact the manufacturer and ask for recommendations as to what can be done to prevent the alarm activation.



PUMP COMPANY

MAIL TO: P.O. BOX 16347 • Louisville, KY 40256-0347
SHIP TO: 3649 Cane Run Road • Louisville, KY 40211-1961
(502) 778-2731 • 1 (800) 928-PUMP • FAX (502) 774-3624

Your Peace of Mind is Our Top Priority®

**visit our web site:
www.zoeller.com**