





Check Valve Replacement Parts

SERIES 716 AND SERIES 717

IMPORTANT INFORMATION

⚠ WARNING				
				
<ul style="list-style-type: none"> • Read and understand all instructions before attempting to install, remove, adjust, or maintain any Victaulic piping products. • Depressurize and drain the piping system before attempting to install, remove, adjust, or maintain any Victaulic piping products. • Wear safety glasses, hardhat, and foot protection. <p>Failure to follow these instructions could result in serious personal injury and/or property damage.</p>				

SECTION VIEW

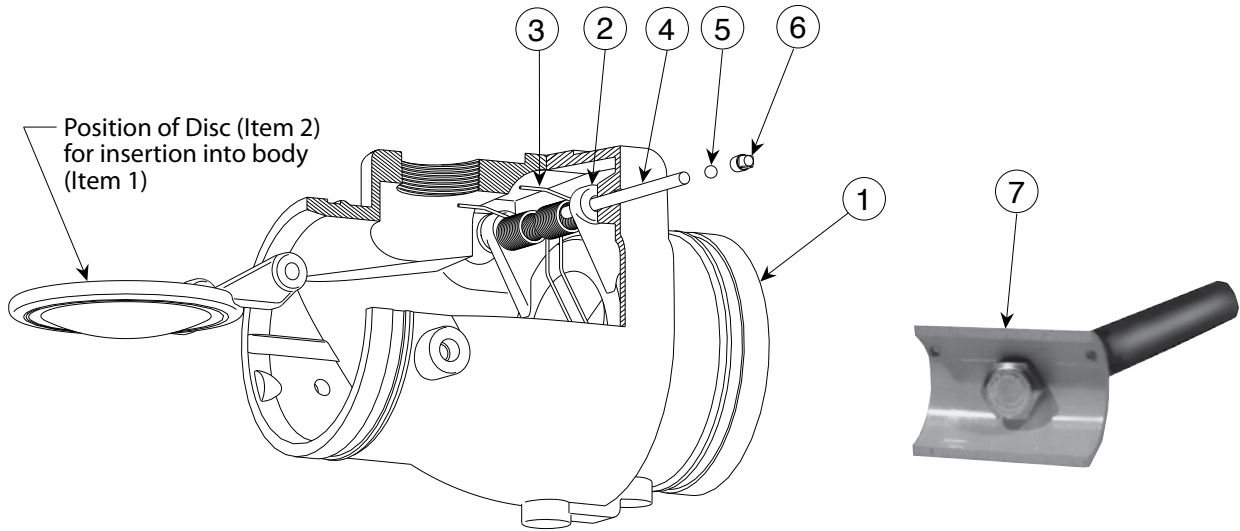

EXPLODED VIEW

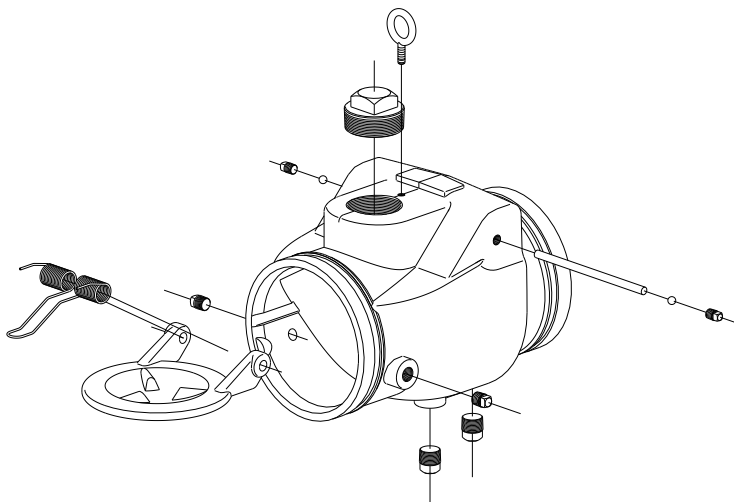

KIT CONTENTS

Item	Description	Quantity
1	Valve Body	1
2	Disc	1
3	Torsion Spring	1
4	Shaft - Type 316 Stainless Steel	1
5	Shaft Lock	2
6	Square-Head Pipe Plug	2
7	Spring Installation Tool	1

Check Valve Replacement Parts

SERIES 716 AND SERIES 717

1. Depressurize and drain the piping system. Remove the check valve from the system.
2. Check the contents of the kit to ensure that all required parts are included. Items 2 - 7, shown on the previous page, should be included with the kit. If any parts are missing, contact Victaulic.
- 2a. Verify that the coating on the disc is suitable for the intended service. Refer to the current product submittal for complete disc coating information.
3. Remove the square-head pipe plugs (Item 6) and shaft locks (Item 5) from the valve body. Push the shaft (Item 4) through the valve body in order to release the disc (Item 2) and torsion spring (Item 3). Remove the disc and torsion spring from the valve body. **NOTE:** Relief slots are provided in the valve body to permit disc removal.
- 3a. Remove dirt and foreign material from the inside of the valve body.
- 3b. Inspect the sealing surface of the valve body for nicks, scratches, and other damage. If damage is present, full valve replacement is recommended.
4. Insert the new disc (provided in the kit) into the valve body. Align the holes in the disc with the holes in the valve body.

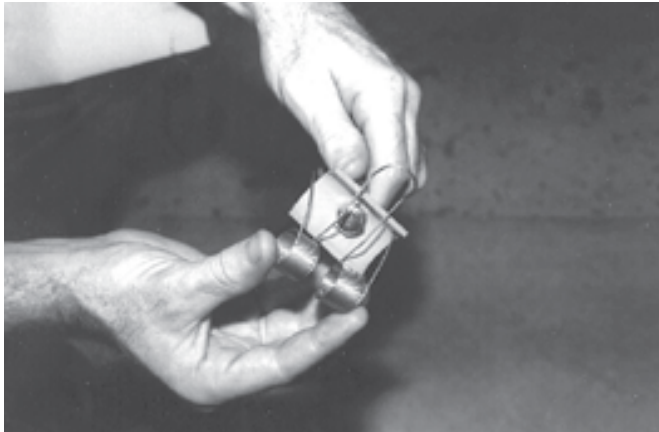

5. Insert the arms of the torsion spring (provided in the kit) into the holes at the edges of the curved guide of the installation tool (Item 7 provided in the kit). The coils of the torsion spring should be seated fully against the guide and on opposite sides of the center spacer.

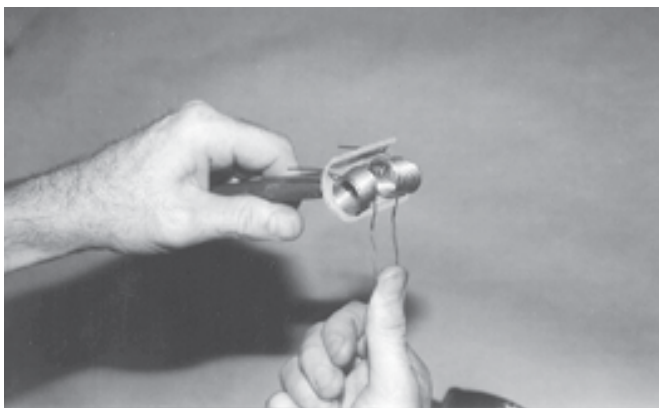

6. Grasp the tongue of the torsion spring with one hand and the handle of the tool with the other hand. Wind the tongue 180° until it contacts the edge of the guide.



7. Insert the torsion spring and tool into the valve body. Position the coils between the ears of the disc in alignment with the shaft holes. While continuing to hold the tool, release the tongue of the torsion spring so that it presses against the center of the disc without unwinding.



8. While holding the tool with one hand, insert the new shaft (provided in the kit) into the valve. Pass the shaft through the disc, torsion spring, and into the other side of the valve body.
9. Remove the installation tool. Check the disc and torsion spring position, while swinging the disc from closed to open position. Verify that the torsion spring arms and tongue are positioned, as shown in the drawing on the previous page.
10. Install the new shaft locks (provided in the kit) at each end of the shaft.
- 10a. Apply thread sealant or Teflon* tape to the new square-head pipe plugs (provided in the kit). Install the square-head pipe plugs into the valve body, and tighten the plugs to a torque of 10 ft-lbs/ 14 N•m.

* Teflon is a registered trademark of the DuPont Company

For complete contact information, visit www.victaulic.com

I-716/717.KIT4 0535 REV B UPDATED 06/2009 Z040716001

VICTAULIC IS A REGISTERED TRADEMARK OF VICTAULIC COMPANY. © 2009 VICTAULIC COMPANY. ALL RIGHTS RESERVED. PRINTED IN THE USA.

I-716/717.KIT4

