

## VIII. MAINTENANCE AND REPAIR - LD/WD2000/3000/5000 SERIES - 2" THRU 12" SIZE VALVES ONLY

Due to the many unique features in the NIBCO butterfly valve design, there is no regular maintenance or lubrication required.

These valves are field repairable\* with the stem, disc, seat and body, collar bushing and O-ring seals available as individual components.

### IX. REPAIR

Remove handle, gear operator or actuator from the cast-mounting pad. Unscrew the collar bushing\*\* and pull out the stem; this will allow the disc to be removed as well.

Replacement of the damaged component can be accomplished at this time. The body, seat and bushings are provided from the factory as one assembly rather than three separate components.

To reassemble, place the disc inside the seat in the open position. Align the stem hole thru the body and disc. Insert the stem into the body and disc, making sure to align the geometric drive flats between the stem and disc.

Replace both stem and body O-ring seals on the collar bushing and insert over the stem. Screw the bushing into the body until flush with top of mounting pad. Replace lever, gear or actuator and check for function before reinstalling in line.

Refer to assembly drawing below for individual components.

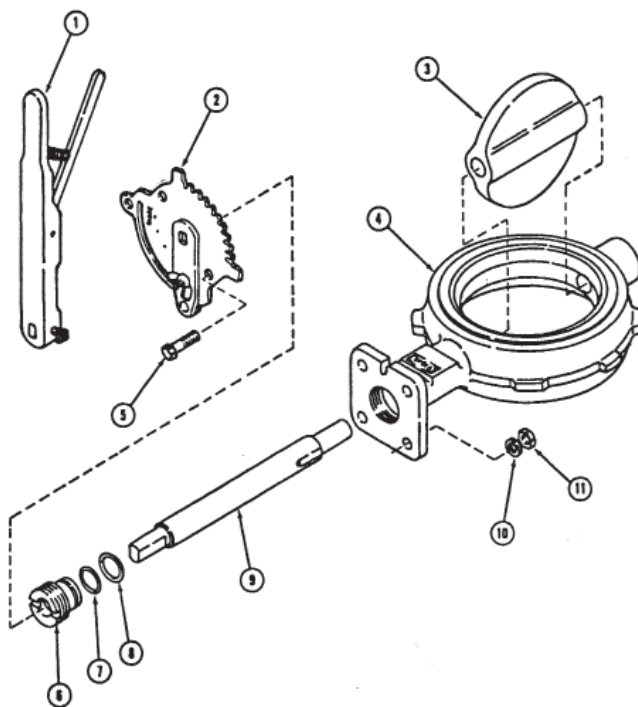

### MATERIAL LIST

ITEM	DESCRIPTION
1.	Lever Handle
2.	Throttle Plate*
3.	Disc
4.	Wafer Body and Liner
5.	Hex Bolt (3/8 x 2)
6.	Collar Bushing
7.	O-ring Body Seal
8.	O-ring Stem Seal
9.	Stem
10.	Washer (3/8 x 2)
11.	Nut (3/8-16 x 2)

\* Shown with optional Infinite-Position Kit.

### GEAR OPERATORS

All gear operators are lubricated for life at assembly, prior to shipment from factory.

During installation, customer should carefully adjust gear operators to suit the valve OPEN and SHUT positions; no further attention is normally required throughout the product life.

For installations where spare parts are held on site, it is suggested that a spare gear operator be held as an interchangeable item. In the event of gear operator suffering damage or excessive wear in service, it is recommended that a replacement be supplied.

\*\* Never remove the collar bushing with the system under pressure.