

# 175 PSI WWP Bronze Gate Valves

Fire Protection Valve • Screw-over Bonnet •  
Outside Screw and Yoke • Solid Wedge

**175 PSI/12.1 Bar Non-Shock Cold Water  
(400 PSI Non-Shock CWP General Service)**

UL/ULC LISTED\* • FM APPROVED •  
APPROVED BY THE NEW YORK CITY B.S.A. 143-69-SA

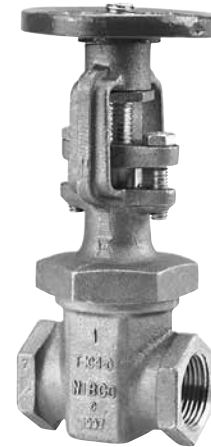
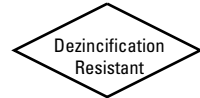

**T-104-0**  
Threaded

### MATERIAL LIST

PART	SPECIFICATION
1. Set Screw	Steel ASTM A307
2. Handwheel	Malleable Iron
3. Yoke Bushing	Brass ASTM B16
4. Gland Bolts	Steel ASTM A307 Zinc Plated
5. Packing Gland	Bronze ASTM B62
6. Packing	Non Asbestos Aramid Fibers w/Graphite
7. Bonnet	Bronze ASTM B62
8. Stem	Silicon Bronze ASTM B371 Alloy C69430
9. Stem Collar	Silicon Bronze ASTM B371 Alloy C69430
10. Wedge Pin	Bronze ASTM B140 Alloy C31400
11. Wedge	Bronze ASTM B62
12. Body	Bronze ASTM B62

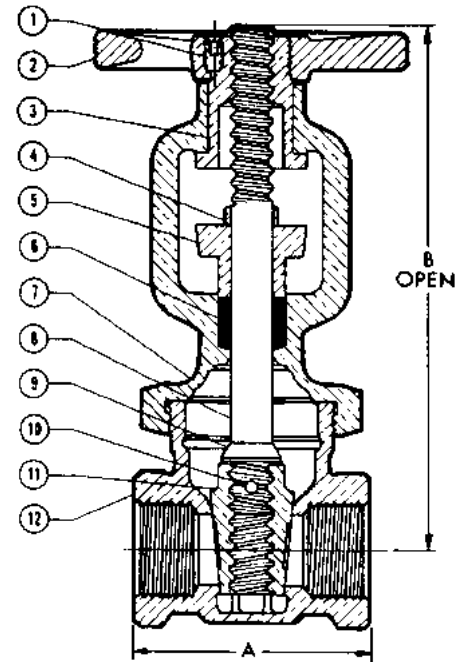

**T-104-0**  
NPT x NPT

### DIMENSIONS—WEIGHTS—QUANTITIES

Size	Dimensions				Diameter		Handwheel Weight		Box Qty.	Master Ctn. Qty.	
	In.	mm.	In.	mm.	In.	mm.	Lbs.	Kg.			
1/2	15	2.19	59	5.88	149	3.25	88	2.28	1.04	1	20
3/4	20	2.44	62	6.44	164	3.25	88	2.83	1.29	1	20
1	25	2.88	73	7.44	189	3.25	88	3.67	1.67	1	10
1 1/4	32	3.13	79	8.69	221	4.00	100	5.83	2.65	1	10
1 1/2	40	3.38	84	9.38	238	4.00	100	6.84	3.11	1	10
2	50	3.44	87	10.59	269	3.50	89	9.74	4.44	1	6

\* Compliance with Standard for Gate Valves for Fire Protection Service, UL 262, and the Canadian Requirements.

