

## 150# Y-PATTERN SWING CHECK VALVE FEDERAL SPECIFICATION

**Features:**

- 300 WOG
- 150 PSI Saturated Steam
- Resilient Disc
- NPT Ends
  - Fig. 1241 - Sizes 1/2" to 3"
- Solder Ends
  - Fig. 1242 - Sizes 1/2" to 3"
- Conforms to MSS SP-80
- Body Markings Comply with MSS SP-25
- NPT Ends Comply with ANSI/ASME B1.20.1
- Solder Ends Comply with ANSI B16.18

Note: Before installing solder end valves, be sure the solder or brazing alloy melting point is sufficient to withstand the line pressure and temperature and is compatible with the media through the valve.



**Cv & Weights (lbs.)**

Size	Cv	1241	1242
1/2	4.8	0.60	0.56
3/4	14.3	0.91	0.80
1	24	1.35	1.30
1-1/4	43	2.18	1.95
1-1/2	60	3.06	2.70
2	102	4.57	4.45
2-1/2	150	7.70	7.68
3	238	11.00	9.15

**Figure Number Matrix**

FNW 1 2 4 1 Size		
END TYPE	SIZE CODE	
1 = NPT Ends	1/2 = D	1-1/2 = J
2 = Solder Ends	3/4 = F	2 = K
	1 = G	2-1/2 = L
	1-1/4 = H	3 = M

## 150# Y-PATTERN SWING CHECK VALVE FEDERAL SPECIFICATION

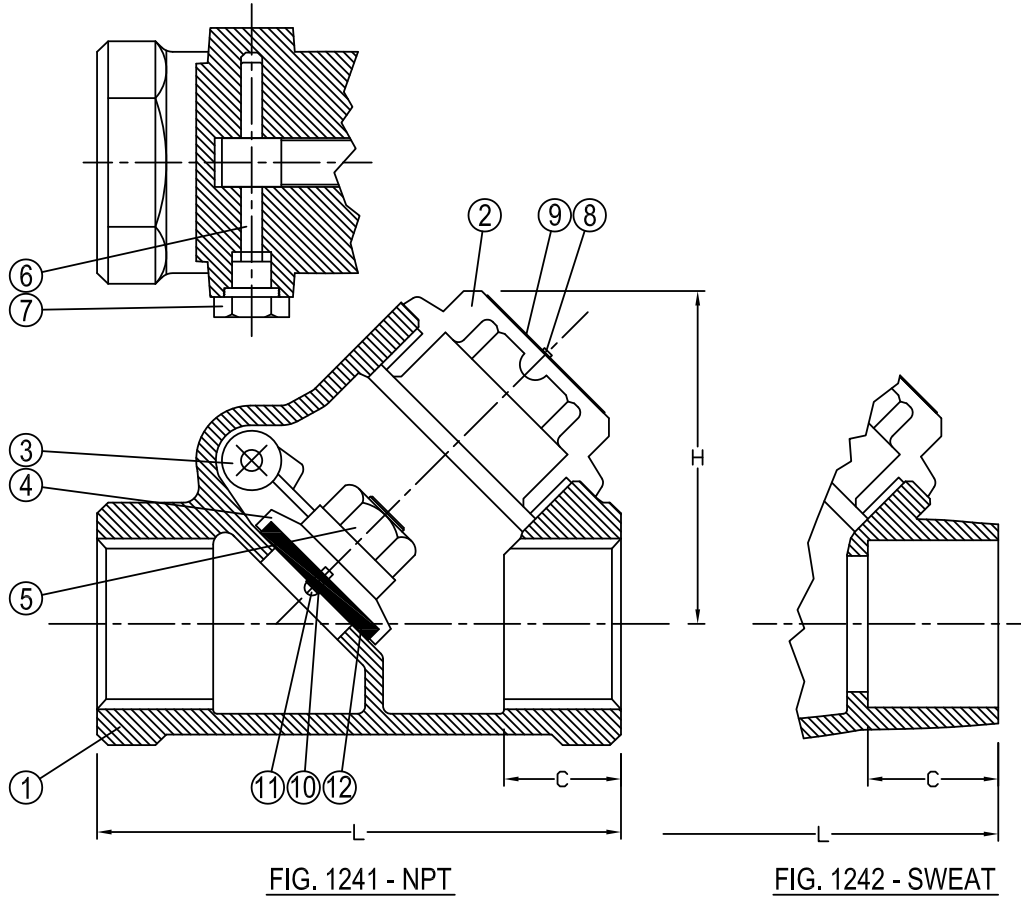

FIG. 1241 - NPT

FIG. 1242 - SWEAT

### Dimensions (inches)

SIZE	L		C		H	
	1241	1242	1241	1242	1241	1241
1/2	2.36	2.60	0.54	0.50	1.77	1.77
3/4	2.76	3.39	0.57	0.75	1.97	1.97
1	3.40	4.09	0.70	0.91	2.28	2.28
1-1/4	3.78	4.72	0.71	0.97	2.67	2.67
1-1/2	4.57	5.39	0.75	1.09	2.95	2.95
2	5.35	6.69	0.79	1.34	3.70	3.70
2-1/2	6.72	7.64	1.14	1.47	4.65	4.55
3	7.55	8.74	1.18	1.66	5.47	5.37

### Standard Materials

Ref. No.	Description	Material
1	Body	BRONZE ASTM B62 C83600
2	Cap	BRONZE ASTM B62 C83600
3	Hanger	BRONZE ASTM B62 C83600
4	Disc Holder	BRONZE ASTM B62 C83600
5	Hanger Nut	BRASS ASTM B16 C36000
6	Hanger Pin	BRASS ASTM B16 C36000
7	Side Plug	BRASS ASTM B16 C36000
8	Rivet	MILD STEEL
9	Name Plate	COMMERCIAL ALUMINUM
10	Washer	BRASS ASTM B16 C36000
11	Screw	BRASS ASTM B16 C36000
12	Disc	TEFLON (PTFE)

DOC: FNW1241-124206 Ver. 1/2012

© 2012 - FNW. All rights reserved.

The FNW logo is a trademark of Ferguson Enterprises, Inc., PL Sourcing, PO Box 2778, Newport News, VA 23609

The contents of this publication are presented for information purposes only, and while effort has been made to ensure their accuracy, they are not to be construed as warranties or guarantees, expressed or implied, regarding the products or services described herein or their use or applicability. All sales are governed by our terms and conditions, which are available on request. We reserve the right to modify or improve the designs or specifications of our products at any time without notice. Always verify that you have the most recent product specifications or other documentation prior to the installation of these products.