

FIGURE 7815 STRUT CLAMPS



CUSHIONED PIPE STRUT CLAMP

FEATURES

- Material: thermoplastic elastomer
- Temperature range: -65°F to 275°F
- Hardness shore "A" (per ASTM D-792)
- Dielectric strength: 670 volts/mil

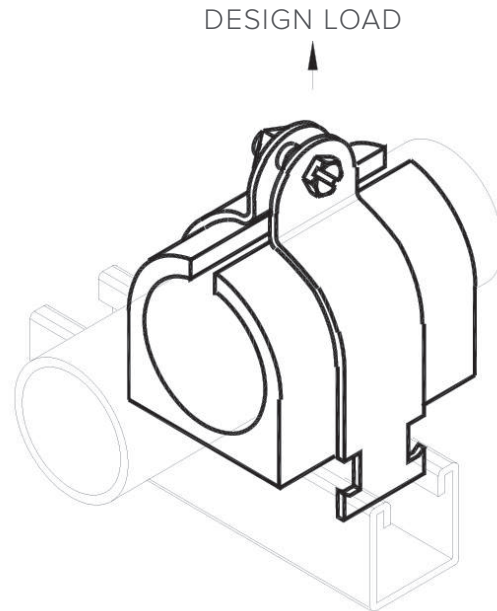

REFERENCE CHART

Item #	Pipe Size		O.D.		Design Load	
	In.	Metric	In.	mm	Lbs.	kN
FNW7815Y0050	1/2	15	0.840	21.3	330	1.48
FNW7815Y0075	3/4	20	1.050	26.7	330	1.48
FNW7815Y0100	1	25	1.315	33.4	330	1.48
FNW7815Y0125	1-1/4	32	1.660	42.2	730	3.26
FNW7815Y0150	1-1/2	40	1.900	48.3	730	3.26
FNW7815Y0200	2	50	2.375	60.3	730	3.26
FNW7815Y0250	2-1/2	65	2.875	73.0	730	3.26
FNW7815Y0300	3	80	3.500	88.9	1200	5.34
FNW7815Y0400	4	100	4.500	114.3	1200	5.34