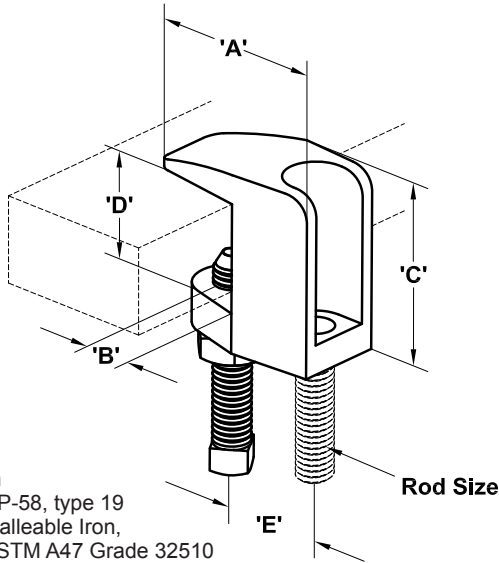

**FIGURE 7204 - Wide Mouth Beam Clamp**



Finish: Plain  
 Per: MSS SP-58, type 19  
 Material: Malleable Iron,  
 ASTM A47 Grade 32510

Hanger rod not included

Rod Size	A	B	C	D	E	Wt. (Oz.)
3/8"-16	1.63"	0.50"	1.88"	1.25"	1.06"	7.65
1/2"-13	1.63"	0.50"	1.88"	1.25"	1.06"	7.65
5/8"-11	2.25"	0.75"	2.31"	1.25"	1.38"	11.25
3/4"-10	2.38"	0.75"	2.38"	1.25"	1.38"	14.11

Catalog Number	Finish	Rod Size	Max. Load (Lbs.)
FNW7204PC	Plain	3/8"-16	400
FNW7204PD	Plain	1/2"-13	500
FNW7204PE	Plain	5/8"-11	850
FNW7204PF	Plain	3/4"-10	900

Note: Do not overtighten the set screw or the clamp can be damaged. The set screw should be finger tight, then given approximately an additional 1/4 to 1/3 turn. The recommended set screw torque is 5 ft-lbs (60 in-lbs).

**FIGURE 7806 - Universal Beam Clamp**

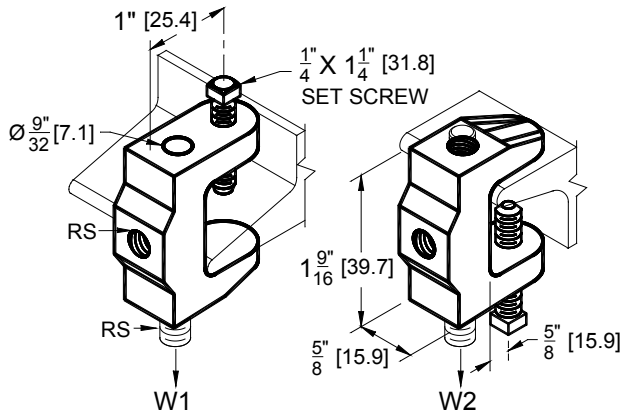

Maximum flange thickness of 5/8"

Finish: Zinc  
 Material: Malleable Iron  
 Hanger rod not included

Catalog Number	Rod Size (RS)	Max Load (W1)		Max Load (W2)	
		Lbs.	kN	Lbs.	kN
FNW7806Z	1/4"-20	100	0.44	250	1.11

Note: The threaded hole on the back side of the clamp is note load rated.

**FIGURE 7868 - Right Angle Clamp**

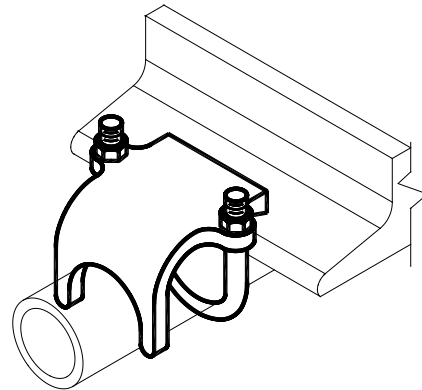

Standard finish is hot dip galvanized

Catalog Number	Pipe Size	
	Inch	Metric
FNW7868Z0050	1/2	15
FNW7868Z0075	3/4	20
FNW7868Z0100	1	25
FNW7868Z0150	1-1/2	40
FNW7868Z0200	2	50

**FIGURE 7801 - Window Strut to Beam Clamp**

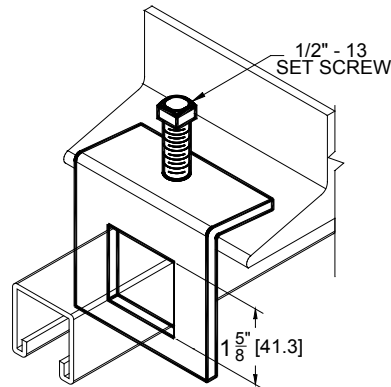

Design load 950 Lbs [4.23 kN] when used in pairs  
 Catalog Number: FNW7801Z

**FIGURE 7802 - Strut to Beam Spreader Caps**

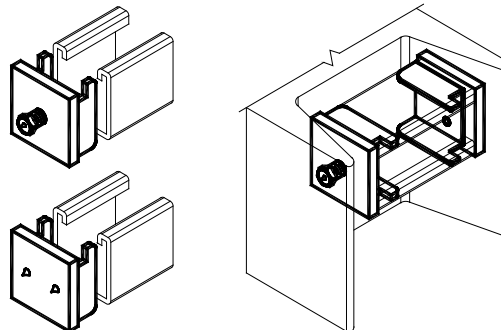

Includes 1 adjustable cap and 1 nonadjustable cap  
 Cut strut length to opening minus 1" [25mm]  
 Design load 500 Lbs [2.22 kN] when used as a set  
 Catalog Number: FNW7802Z