



PF92017 Pre-Assembled Remote Sink / Drain Pump System

Pump Features

- Rugged cast iron pump body for durability
- SJE Rhombus vertical float switch
- 1-1/2" NPT Discharge
- Handles up to 3/8" solids
- Clog resistant stainless steel impeller
- Carrying handle attached
- 10' power supply cord
- Built-in thermal overload protection for safety
- Permanent split capacitor continuous duty motor
- 4.1 amps, 492 Watts
- 3450 RPM
- Will handle temperatures up to 120° F
- Passes laundry lint



PF92017

Basin Features

- Structural foam construction
- Corrosion resistant
- 5 Gallon capacity
- 1-1/2" FPT Inlet
- Gasket sealed, air tight cover
- 1-1/2" FPT discharge & vent

Check Valve Features

- Fits 1-1/2" or 1-1/4" pipe
- Stainless steel clamps
- ABS body

Motor Performance

- .3 HP 120 Volt AC (4.1 amps)

Performance Chart						
Lift	0'	5'	10'	15'	20'	25'
GPM	46	36	30	25	12	1
GPH	2760	2160	1800	1500	720	60

Product Specifications

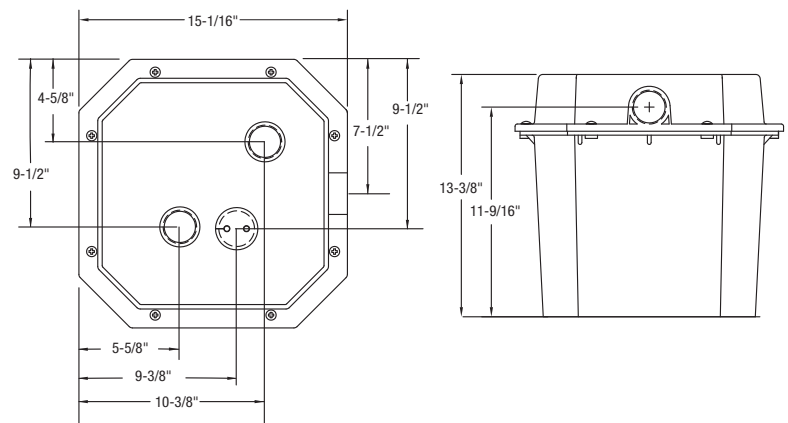

* All measurements are nominal. Please verify before actual installation.

Warranty and Codes

This product comes complete with installation, operating, care and maintenance instructions. This PROFLO remote sink / drain pump system carries a 5 year warranty when installed in residential applications. See owners manual for warranty details.

This PROFLO remote sink / drain pump system carries a 5 year limited warranty. In an effort to continually improve our products, we will make design changes from time to time. We reserve the right to ship newly designed product to fill any order unless it is agreed in writing to do otherwise.



PROFLO.COM