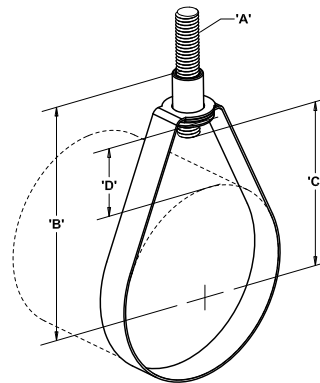

FIGURE 7010 - Adjustable Swivel Ring Hangers



UL Approved - Sizes 1/2" to 8"
FM Approved - Sizes 3/4" to 8"

Finish: Epoxy Plated
Color: Zinc
MSS SP-58, Type 10
Federal Specification WW-H-171, Type 10
NFPA 13



A - Rod size (hanger rod not included)
B - Center of pipe to top of knured hanger rod nut
C - Rod take out (center of pipe to bottom of hanger rod)
D - Top of pipe to bottom of hanger rod nut

Catalog Number	Pipe Size		A (Rod size)	B		C		D		Design Load		Weight Lbs.
	in.	mm		in.	mm	in.	mm	in.	mm	Lbs.	kN	
FNW7010EP0050	1/2	21.3	3/8-16UNC	2-7/32	56.36	25/32	19.8	7/8	22.2	300	1.33	0.09
FNW7010EP0075	3/4	26.6	3/8-16UNC	2-7/16	61.91	1-1/32	26.2	1-3/32	27.8	300	1.33	0.09
FNW7010EP0100	1	33.4	3/8-16UNC	2-5/8	66.68	1-7/32	31.0	1-3/16	30.2	300	1.33	0.10
FNW7010EP0125	1-1/4	42.1	3/8-16UNC	2-25/32	70.64	1-3/8	34.9	1-5/32	29.4	300	1.33	0.11
FNW7010EP0150	1-1/2	48.2	3/8-16UNC	2-7/8	73.03	1-7/16	36.5	1-3/32	27.8	300	1.33	0.12
FNW7010EP0200	2	60.3	3/8-16UNC	3-1/32	76.99	1-19/32	40.5	1-1/32	26.2	300	1.33	0.13
FNW7010EP0250	2-1/2	73	3/8-16UNC	3-31/32	100.81	2-9/16	65.1	1-23/32	43.7	525	4.45	0.29
FNW7010EP0300	3	88.9	3/8-16UNC	4-15/32	113.51	3-1/16	77.8	1-15/16	49.2	525	4.45	0.33
FNW7010EP0350	3-1/2	101.6	3/8-16UNC	4-15/16	125.41	3-17/32	89.7	2-1/8	54.0	585	4.45	0.37
FNW7010EP0400	4	114.3	3/8-16UNC	5-9/32	134.14	3-27/32	97.6	2-3/16	55.6	650	4.89	0.39
FNW7010EP0500	5	141.3	1/2-13UNC	5-31/32	151.61	4-7/16	112.7	2-1/4	57.2	1000	4.89	0.53
FNW7010EP0600	6	168.2	1/2-13UNC	7	177.80	5-1/2	139.7	2-3/4	69.9	1000	5.56	0.72
FNW7010EP0800	8	219	1/2-13UNC	7-31/32	202.41	6-7/16	163.5	2-23/32	69.1	1000	5.56	1.04

FIGURE 7012 - Felt Lined Adjustable Swivel Ring Hangers



UL Approved - Sizes 1/2" to 4"
FM Approved - Sizes 3/4" to 4"
NFPA Rod - Sizes 1/2" to 4" *

Finish: Epoxy Plated
Color: Zinc
MSS SP-58, Type 10
Federal Specification WW-H-171, Type 10
NFPA 13

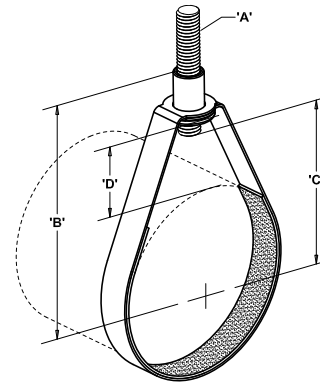

A - Rod size (hanger rod not included)
B - Center of pipe to top of knured hanger rod nut
C - Rod take out (center of pipe to bottom of hanger rod)
D - Top of pipe to bottom of hanger rod nut

* Note: For 2-1/2" to 4" hangers with NFPA rod sizes, use figure number 7012N

Catalog Number	Pipe Size		A (Rod size)	B		C		D		Design Load		Weight Lbs.
	in.	mm		in.	mm	in.	mm	in.	mm	Lbs.	kN	
FNW7012EP0050	1/2	21.3	3/8-16UNC	2-7/32	56.36	25/32	19.8	7/8	22.2	300	1.33	0.089
FNW7012EP0075	3/4	26.6	3/8-16UNC	2-7/16	61.91	1-1/32	26.2	1-3/32	27.8	300	1.33	0.095
FNW7012EP0100	1	33.4	3/8-16UNC	2-5/8	66.68	1-7/32	31.0	1-3/16	30.2	300	1.33	0.100
FNW7012EP0125	1-1/4	42.1	3/8-16UNC	2-25/32	70.64	1-3/8	34.9	1-5/32	29.4	300	1.33	0.112
FNW7012EP0150	1-1/2	48.2	3/8-16UNC	2-7/8	73.03	1-7/16	36.5	1-3/32	27.8	300	1.33	0.121
FNW7012EP0200	2	60.3	3/8-16UNC	3-1/32	76.99	1-19/32	40.5	1-1/32	26.2	300	1.33	0.130
FNW7012EP0250	2-1/2	73	1/2-13UNC	3-31/32	100.81	2-9/16	65.1	1-23/32	43.7	1000	2.34	0.323
FNW7012EP0300	3	88.9	1/2-13UNC	4-15/32	113.51	3-1/16	77.8	1-15/16	49.2	1000	2.34	0.359
FNW7012EP0400	4	114.3	5/8-11UNC	5-9/32	134.14	3-27/32	97.6	2-3/16	55.6	1100	2.89	0.474
FNW7012NEP0250*	2-1/2	73	3/8-16UNC	3-31/32	100.81	2-9/16	65.1	1-23/32	43.7	525	2.34	0.323
FNW7012NEP0300*	3	88.9	3/8-16UNC	4-15/32	113.51	3-1/16	77.8	1-15/16	49.2	525	2.34	0.359
FNW7012NEP0400*	4	114.3	3/8-16UNC	5-9/32	134.14	3-27/32	97.6	2-3/16	55.6	650	2.89	0.474