

SPECIFICATIONS

FIGURE 7005E
HANGERS



STANDARD DUTY ADJUSTABLE CLEVIS HANGER

FEATURES

- Finish: Epoxy plated
- Color: Zinc
- Hanger body: ASTM A240
- UL/FM Approved: Sizes 2-1/2" to 8"

PRODUCT SPECIFICATIONS

Standards

- Design: MSS SP-58, Type 1
- Federal specification: WW-H-171, Type 1

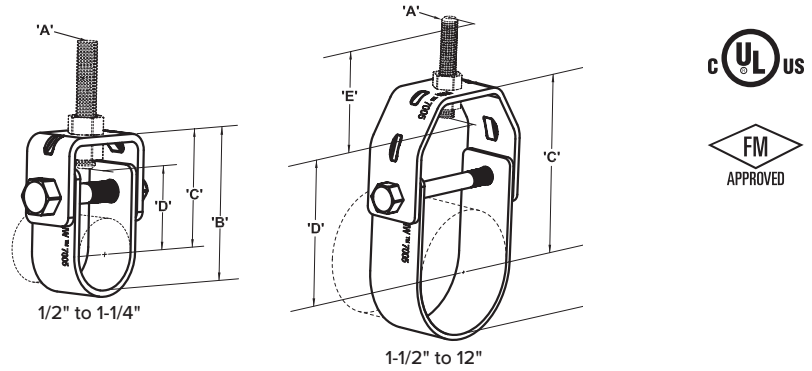

Note: A - Rod size (hanger rod and nuts not included), B - Bottom of pipe to top of hanger
 C - Center of pipe to top of hanger, D - Rod take out (center of pipe to bottom of hanger rod), E - Minimum thread length of hanger rod, F - Adjustment, top of cross bolt to bottom of hanger rod nut inside hanger

DIMENSIONS

Catalog Number	Pipe Size		A Rod Size	B		C		D	
	in.	mm		in.	mm	in.	mm	in.	mm
FNW7005EP0050	1/2	21.30	3/8"-16	2.00	50	1.54	39	0.37	9.50
FNW7005EP0075	3/4	26.60	3/8"-16	2.28	58	1.73	44	0.60	15.30
FNW7005EP0100	1	33.40	3/8"-16	2.68	68	2.00	51	0.89	22.50
FNW7005EP0125	1-1/4	42.10	3/8"-16	3.31	84	2.44	62	1.26	31.90
FNW7005EP0150	1-1/2	48.20	3/8"-16	3.86	98	2.87	73	1.77	44.90
FNW7005EP0200	2	60.30	3/8"-16	4.41	112	3.19	81	1.94	49.40
FNW7005EP0250	2-1/2	73.00	1/2"-13	5.12	130	3.66	93	2.28	57.90
FNW7005EP0300	3	88.90	1/2"-13	6.00	151	4.13	105	2.72	69.20
FNW7005EP0350	3-1/2	101.60	1/2"-13	6.54	166	4.49	114	3.08	78.20
FNW7005EP0400	4	114.30	5/8"-11	7.48	190	5.16	131	3.69	93.60
FNW7005EP0500	5	141.30	5/8"-11	9.21	234	6.38	162	4.61	117.00
FNW7005EP0600	6	168.20	3/4"-10	10.51	267	7.13	181	5.31	134.80
FNW7005EP0800	8	219.10	3/4"-10	13.00	328	8.50	216	6.48	164.70
FNW7005EP1000	10	273.10	7/8"-9	15.51	394	10.00	254	7.65	194.20
FNW7005EP1200	12	323.90	7/8"-9	18.62	473	12.13	308	9.75	247.60

Catalog Number	Pipe Size		E		F		Bolt Size	Design Load		Weight lbs
	in.	mm	in.	mm	in.	mm		lbs	kN	
FNW7005EP0050	1/2	21.30	2.50	63.50	0.44	11.10	1/4"-20UNC	610	2.71	0.12
FNW7005EP0075	3/4	26.60	2.50	63.50	0.50	12.70	1/4"-20UNC	610	2.71	0.14
FNW7005EP0100	1	33.40	2.50	63.50	0.63	15.90	1/4"-20UNC	610	2.71	0.16
FNW7005EP0125	1-1/4	42.10	2.50	63.50	0.87	22.20	1/4"-20UNC	610	2.71	0.24
FNW7005EP0150	1-1/2	48.20	2.50	63.50	1.19	30.20	1/4"-20UNC	610	2.71	0.25
FNW7005EP0200	2	60.30	2.50	63.50	1.63	41.30	1/4"-20UNC	610	2.71	0.35
FNW7005EP0250	2-1/2	73.00	2.50	63.50	2.00	50.80	3/8"-16UNC	1,130	5.02	0.61
FNW7005EP0300	3	88.90	2.50	63.50	2.00	50.80	3/8"-16UNC	1,130	5.02	0.71
FNW7005EP0350	3-1/2	101.60	2.50	63.50	2.00	50.80	3/8"-16UNC	1,130	5.02	0.79
FNW7005EP0400	4	114.30	2.50	63.50	2.00	50.80	3/8"-16UNC	1,430	6.36	1.00
FNW7005EP0500	5	141.30	2.50	63.50	2.00	50.80	1/2"-13UNC	1,430	6.36	1.67
FNW7005EP0600	6	168.20	3.00	76.20	2.00	50.80	1/2"-13UNC	1,940	8.62	3.05
FNW7005EP0800	8	219.10	3.50	88.90	2.31	58.70	5/8"-11UNC	2,000	8.89	4.11
FNW7005EP1000	10	273.10	3.50	88.90	2.31	58.70	3/4"-10UNC	3,600	16.00	6.75
FNW7005EP1200	12	323.90	3.50	88.90	2.63	66.70	3/4"-10UNC	3,800	16.89	7.88

SPECIFICATIONS

FIGURE 7005E HANGERS



STANDARD DUTY LARGE DIAMETER ADJUSTABLE CLEVIS HANGER

FEATURES

- Finish: Epoxy plated
- Color: Zinc

PRODUCT SPECIFICATIONS

Standards

- Design: MSS SP-58, Type 1
- Federal specification: WW-H-171, Type 1

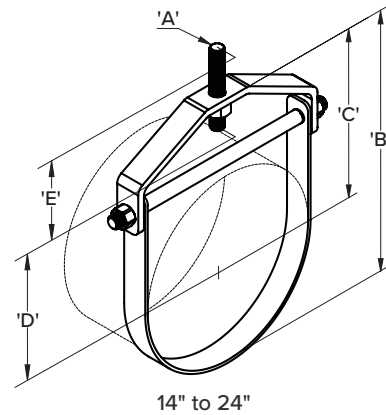

Note: A - Rod size (hanger rod and nuts not included), B - Bottom of pipe to top of hanger
 C - Center of pipe to top of hanger, D - Rod take out (center of pipe to bottom of hanger rod), E - Minimum thread length of hanger rod, F - Adjustment, top of cross bolt to bottom of hanger rod nut inside hanger

DIMENSIONS

Catalog Number	Pipe Size		A Rod Size	B		C		D	
	in.	mm		in.	mm	in.	mm	in.	mm
FNW7005EP1400	14	355.60	1"-8	21.16	537.50	13.67	347.20	11.09	281.60
FNW7005EP1600	16	406.40	1"-8	23.48	596.50	15.00	380.80	12.87	327.00
FNW7005EP1800	18	457.20	1"-8	27.00	683.50	17.42	442.40	13.94	354.00
FNW7005EP2000	20	508.00	1-1/4"-7	29.69	754.00	19.13	486.00	17.44	442.90
FNW7005EP2400	24	609.60	1-1/4"-7	33.78	858.00	21.23	539.20	20.00	485.50

Catalog Number	Pipe Size		E		F		Bolt Size	Design Load		Weight
	in.	mm	in.	mm	in.	mm		lbs	kN	lbs
FNW7005EP1400	14	355.60	4.00	101.60	2.87	73.00	1"-8UNC	4,200	18.67	18.15
FNW7005EP1600	16	406.40	4.00	101.60	3.37	85.70	1"-8UNC	4,600	20.44	23.84
FNW7005EP1800	18	457.20	4.50	114.30	3.37	85.70	1"-8UNC	4,800	21.33	26.79
FNW7005EP2000	20	508.00	4.00	127.00	4.81	122.20	1-1/4"-7UNC	4,800	21.33	43.53
FNW7005EP2400	24	609.60	4.00	127.00	5.25	133.30	1-1/4"-7UNC	4,800	21.33	50.39