

► Description

Exposed, Battery Powered, Sensor Activated Sloan ECOS® Electronic Model Urinal Flushometer with Smart Sense Technology™.

► Flush Cycle

- Model 8186-0.125 High Efficiency (0.125 gpf/0.5 Lpf)
- Model 8186-0.25 High Efficiency (0.25 gpf/1.0 Lpf)
- Model 8186-0.5 High Efficiency (0.5 gpf/1.9 Lpf)

► Specifications

Quiet, Exposed, Chrome Plated Urinal Flushometer for either left or right hand supply with the following features:

For flushing volumes 0.125 gpf and 0.25 gpf:

- Pressure compensating cartridge assembly
- Synthetic rubber seals for chloramine resistance

For flushing volume 0.5 gpf:

- PERMEX® Synthetic Rubber Flex Tube Diaphragm with twin linear filtered bypass and vortex cleansing action

- Flush Accuracy Controlled by CID™ Technology

For all flushing volumes:

- Latching Solenoid Operator
- Engineered Metal Cover with replaceable Lens Window
- User friendly three (3) second Flush Delay
- Courtesy Flush® Override Button (optional)
- Four (4) Size AA Batteries factory installed
- "Low Battery" Flashing LED
- Infrared Sensor Range Adjustment Screw
- Initial Set-up Range Indicator Light (first 10 minutes)
- 3/4" I.P.S. Screwdriver Bak-Chek® Angle Stop
- Free Spinning, Vandal Resistant Stop Cap
- Adjustable Tailpiece
- Spud Coupling and Flange for 3/4" Top Spud
- Reduces water usage up to 80% over standard sensor urinal
- ADA Compliant Sloan ECOS® Battery Powered Infrared Sensor for automatic "No Hands" operation
- Infrared Sensor with Multiple-focused, Lobular Sensing Fields for high and low target detection
- High Back Pressure Vacuum Breaker Flush Connection with One-piece Bottom Hex Coupling Nut
- Sweat Solder Adapter with Cover Tube and Cast Wall Flange with Set Screw
- High Copper, Low Zinc Brass Castings for Dezincification Resistance
- Fixed Metering Bypass and No External Volume Adjustment to Ensure Water Conservation
- Stop Seat and Vacuum Breaker molded from PERMEX® Rubber Compound for Chloramine resistance

Valve Body, Tailpiece and Control Stop shall be in conformance with ASTM Alloy Classification for Semi-Red Brass. Valve in compliance with the applicable sections of ASSE 1037. Installation conforms to ADA requirements.

► Special Finishes

- PB** Polished Brass (PVD Finish)
- BN** Brushed Nickel (PVD Finish)
- SF** Satin Finish

► Variations

- OR** With Override

► Accessories

See Accessories Section and Sloan ECOS® Accessories Section of the Sloan catalog for details on these and other Sloan ECOS® Flushometer variations.

► Fixtures

Consult Sloan for matching Sloan brand fixture options.



Shown without optional override button

► ADA Compliant

► Manual Operation

Sloan ECOS® Electronic Urinal Flushometers are available without an override button to eliminate unnecessary casual activation. The Sloan ECOS® Flushometers are offered with an *optional* Override Button to allow a "courtesy flush" for individual user comfort.

► Automatic Operation

Sloan ECOS® Electronic Flushometers can also be activated via multi-lobular infrared sensor. By detecting user presence and duration, the Sloan ECOS® Smart Sense Technology™ will determine the proper flush volume for unequalled water efficiency.

► Smart Sense Technology

The Sloan ECOS® Flushometer is equipped with Smart Sense Technology™ which applies extended range and logic techniques to significantly reduce water usage in high use urinal applications; such as when a continuous line of people, also known as a queue, forms. In fact during continuous queue, regardless the number of users, the maximum amount of water used is only 2.0 gallons (8186-0.5). Please contact Sloan for specific details.

► Functional & Hygienic

Touchless, sensor operation eliminates the need for user contact to help control the spread of infectious diseases.

► Warranty

3 year (limited)



Sloan Valve Company is buying renewable energy certificates to meet 100% of the company's purchased electricity use at its Franklin Park, Illinois facility.



This space for Architect/Engineer approval	
Job Name _____	Date _____
Model Specified _____	Quantity _____
Variations Specified _____	
Customer/Wholesaler _____	
Contractor _____	
Architect _____	

► **Description**
Exposed, Battery Powered, Sensor Activated Sloan ECOS® Electronic Model Urinal Flushometer with Smart Sense Technology™.

► **Flush Cycle**
 Model 8186-0.125 High Efficiency (0.125 gpf/0.5 Lpf)
 Model 8186-0.25 High Efficiency (0.25 gpf/1.0 Lpf)
 Model 8186-0.5 High Efficiency (0.5 gpf/1.9 Lpf)

ELECTRICAL SPECIFICATIONS

- | | |
|---|--|
| <p>► Control Circuit
Solid State
6 VDC Input
8 Second Arming Delay
3 Second Flush Delay</p> <p>► OPTIMA Sensor Type
Active Infrared</p> <p>► OPTIMA Sensor Range
Nominal 15" - 30" (381 mm - 762 mm),
Adjustable ± 8" (203 mm)</p> | <p>► Battery Type
Four (4) AA Alkaline</p> <p>► Battery Life
3 Years @ 4,000 Flushes/Month</p> <p>► Indicator Lights
Range Adjustment/Low Battery</p> <p>► Operating Pressure
15 - 100 psi (104 - 689 kPa)</p> <p>► Sentinel Flush
Once Every 72 Hours After the Last Flush</p> |
|---|--|

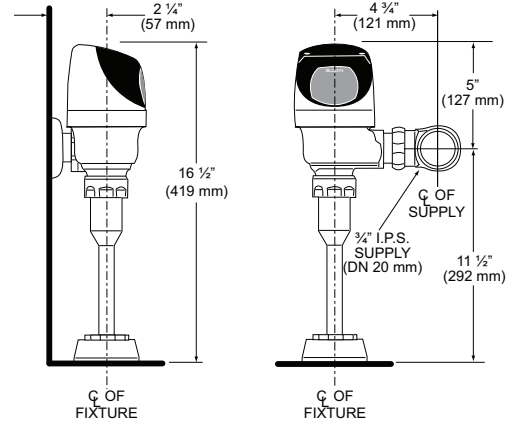

OPERATION

1. A continuous, invisible light beam is emitted from the Sloan ECOS® Sensor.

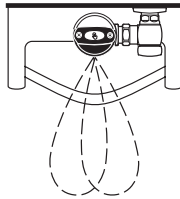

2. As the user enters the beam's effective range, 15" - 30" (381 mm to 762 mm), the beam is reflected into the Scanner Window to activate the Output Circuit. Once activated, the Output Circuit continues in a "hold" mode for as long as the user remains within the effective range of the sensor.

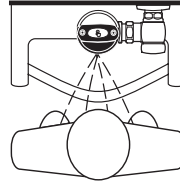

3. When the user steps away from the Sloan ECOS® sensor the sensor initiates an electrical signal that operates the solenoid. This initiates the flushing cycle to flush the fixture. The circuit then automatically resets and is ready for the next user.

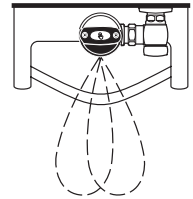

VALVE ROUGH-IN

Model 8186

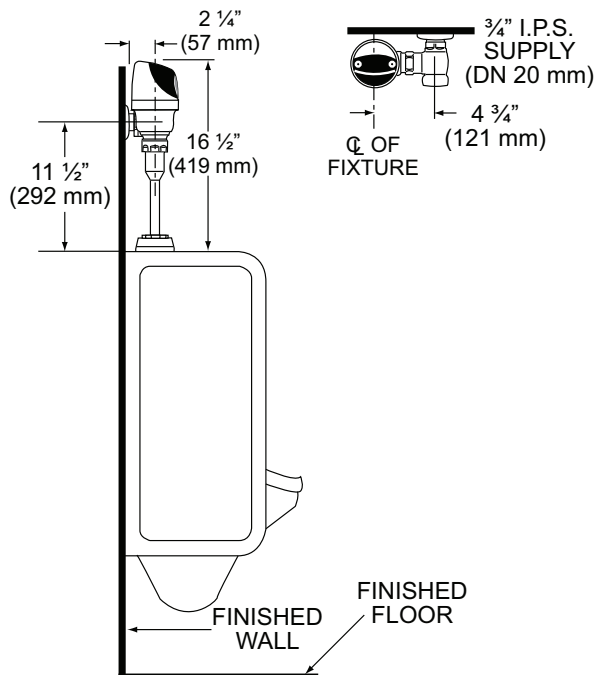

SLOAN • 10500 SEYMOUR AVENUE • FRANKLIN PARK, IL 60131

Phone: 1-800-9-VALVE-9 or 1-847-671-4300 • Fax: 1-800-447-8329 or 1-847-671-4380 • www.sloanvalve.com