

Trusted. Tested. Tough.®

Product information presented here reflects conditions at time of publication. Consult factory regarding discrepancies or inconsistencies.



SECTION: 2.25.070
FM2799
1119
Supersedes
0519



TECHNICAL DATA SHEET

MODEL 840/841/842

DUAL SEAL GRINDER PUMPS

Pump Systems And Controls

PRODUCT SPECIFICATIONS

MOTOR	Horse Power	2
	Voltage	200 - 575
	Phase	1 or 3 Ph
	Hertz	60 Hz
	RPM	3450
	Type	Capacitor start / capacitor run or 3 Ph
	Insulation	Class F
	Amps	4.5 - 20.0
PUMP	Operation	Nonautomatic
	Discharge Size	1-1/4" NPT vertical
	Cord Length	20' (6 m) standard
	Cord Type	SOW or SOOW, multi-wire neoprene
	Max. Head	125' (38.1 m)
	Max. Flow Rate	59 GPM (223 LPM)
	Max. Operating Temp.	130 °F (54 °C)
	Cooling	Oil filled
MATERIALS	Motor Protection	Auto reset thermal overload (1 Ph), thermal sensor (3 Ph)
	Cap	Cast iron
	Motor Housing	Cast iron
	Adapter	Cast iron
	Pump Housing	Cast iron
	Upper Bearing	Ball bearing
	Lower Bearing	Ball bearing
	Mechanical Seals	Carbon/ceramic
	Impeller Type	Non-clogging vortex
	Impeller	Ductile iron
	Hardware	Stainless steel 304
	Motor Shaft	Stainless steel 416
	Square Rings	Neoprene
	Cutter	Hardened stainless steel, Rockwell C55-60

Model 840 (Reversing Grinder Pump)

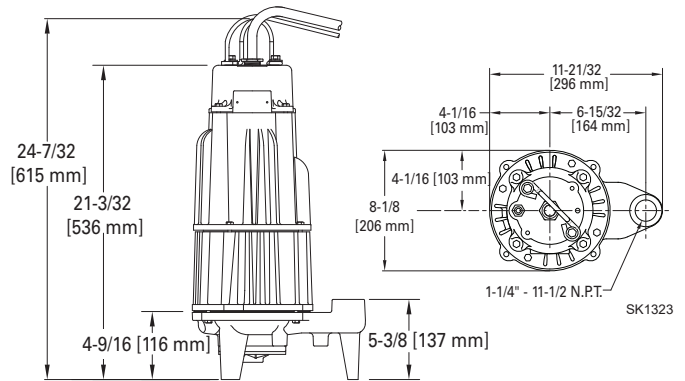

SK1322

Models 841/842 (Single Direction Grinder Pumps)

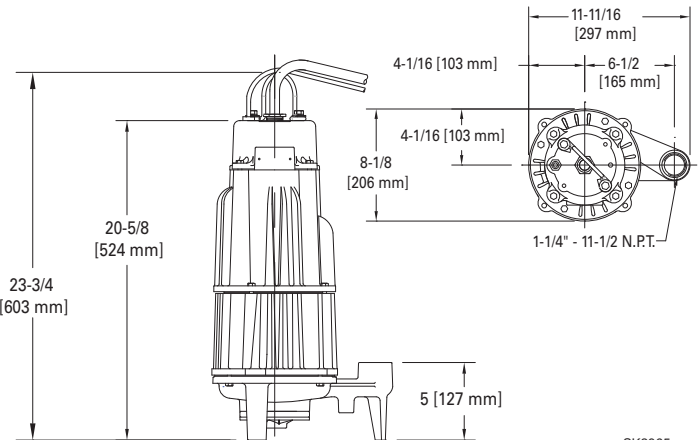

SK2365

NOTE: See model comparison chart for specific details.



© Copyright 2019 Zoeller® Co. All rights reserved.

502-778-2731 | 800-928-7867 | 3649 Cane Run Road | Louisville, KY 40211-1961 | zoellerpumps.com

TOTAL DYNAMIC HEAD FLOW PER MINUTE

MODEL		840		841		842	
Feet	Meters	Gal.	Liters	Gal.	Liters	Gal.	Liters
5	1.5	45	170	54	204	34	129
10	3.0	45	170	54	204	34	129
20	6.1	45	170	54	204	34	129
30	9.1	44	167	54	204	34	129
40	12.2	42	159	54	204	34	129
50	15.2	36	136	52	197	34	129
60	18.3	30	114	49	185	34	129
70	21.3	23	87	43	163	32	121
80	24.4	16	61	36	136	29	110
90	27.4	10	38	28	106	25	95
100	30.5	3	11	19	72	20	76
110	33.5	--	--	11	42	13	49
120	36.6	--	--	4	15	4	15
Shut-off Head:		104 ft (31.7 m)		125 ft (38.1 m)		125 ft (38.1 m)	

016532

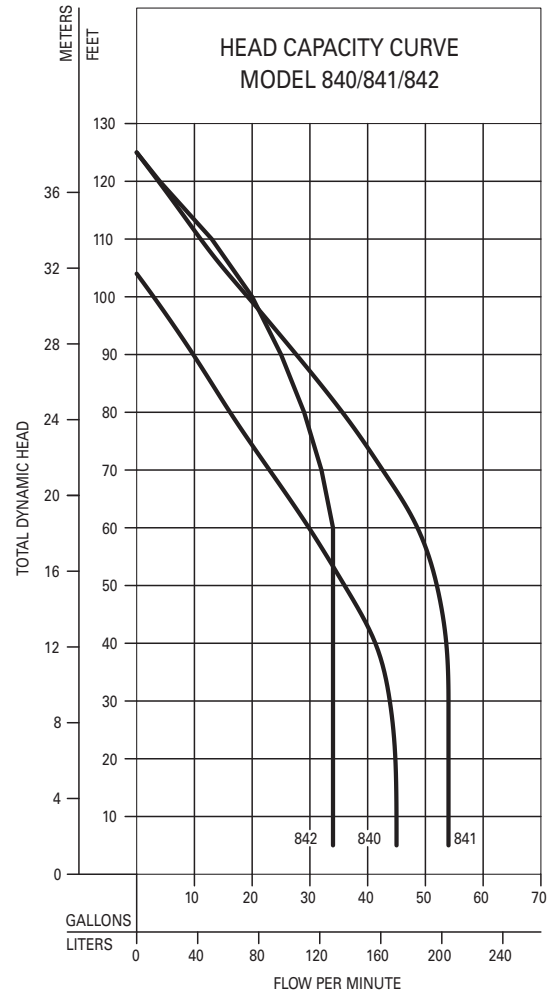

Model	MODEL COMPARISON				
	Volts	Ph	Amps	Lbs	Kg
E840	230	1	17.2	137	62
I840	200	1	20.0	137	62
F840	230	3	10.8	132	60
J840	200	3	12.3	132	60
G840	460	3	5.5	132	60
BA840	575	3	4.5	132	60
I841	200	1	20.0	137	61
E841	230	1	17.2	137	61
J841	200	3	12.3	132	61
F841	230	3	10.8	132	61
G841	460	3	5.5	132	61
BA841	575	3	4.5	132	61
I842	200	1	20.0	137	61
E842	230	1	17.2	137	61
J842	200	3	12.3	132	61
F842	230	3	10.8	132	61
G842	460	3	5.5	132	61
BA842	575	3	4.5	132	61

NOTE: All models are double seal, nonautomatic, 2 HP, and 60 Hz.

- Action can be manual or automatic.
- Panel required for automatic reversing action, thermal sensors and moisture probes.

Model 841 and 842 Electrical Data and Control Panel Selections

Models	Weight	Volts	Phase	HP	Amps	*Start Pak	**NEMA 4X Control Panels	
							Simplex	Duplex
I841	137 lb's (62.1 Kg)	200	1	2	20.0	10-0380	10-1650	10-1652
E841	137 lb's (62.1 Kg)	230	1	2	17.2	10-0380	10-1650	10-1652
J841	132 lb's (59.8 Kg)	200	3	2	12.3	Not Required	10-1097	10-1125
F841	132 lb's (59.8 Kg)	230	3	2	10.8	Not Required	10-1097	10-1125
G841	132 lb's (59.8 Kg)	460	3	2	5.5	Not Required	10-1094	10-1122
BA841	132 lb's (59.8 Kg)	575	3	2	4.5	Not Required	10-1146	10-1168
I842	137 lb's (62.1 Kg)	200	1	2	20.0	10-0380	10-1650	10-1652
E842	137 lb's (62.1 Kg)	230	1	2	17.2	10-0380	10-1650	10-1652
J842	132 lb's (59.8 Kg)	200	3	2	12.3	Not Required	10-1097	10-1125
F842	132 lb's (59.8 Kg)	230	3	2	10.8	Not Required	10-1097	10-1125
G842	132 lb's (59.8 Kg)	460	3	2	5.5	Not Required	10-1094	10-1122
BA842	132 lb's (59.8 Kg)	575	3	2	4.5	Not Required	10-1146	10-1168

** Control Panels include Seal Leak Indication, Visual and Audible High Water Alarm and Dry Contacts. Single Phase Control Panels include Capacitors and Start Relay.



All installation of controls, protection devices and wiring should be done by a qualified licensed electrician. All electrical and safety codes should be followed including the most recent National Electrical Code (NEC) and the Occupational Safety and Health Act (OSHA).

© Copyright 2019 Zoeller® Co. All rights reserved.

502-778-2731 | 800-928-7867 | 3649 Cane Run Road | Louisville, KY 40211-1961 | zoellerpumps.com

MODEL 840 REVERSING GRINDER SYSTEM

A) GRINDER MODEL - 840 2 HP, 1-1/4" N.P.T. VERTICAL DISCHARGE - 20' (6 m) CORDS						
P/N	WGT.	MODEL	VOLTS	PH	AMP	
<input type="checkbox"/> 840-0004	137 lb (62.1 kg)	E840	230	1 ϕ	17.2	
<input type="checkbox"/> 840-0005	137 lb (62.1 kg)	I840	200	1 ϕ	20.0	
<input type="checkbox"/> 840-0006	132 lb (59.9 kg)	F840	230	3	10.8	
<input type="checkbox"/> 840-0007	132 lb (59.9 kg)	J840	200	3	12.3	
<input type="checkbox"/> 840-0008	132 lb (59.9 kg)	G840	460	3	5.5	
<input type="checkbox"/> 840-0009	132 lb (59.9 kg)	BA840	575	3	4.5	

\square Single phase units require a set of capacitors and relay starting components.

MODEL 840 STANDARD FEATURES:

- Reversible cutter action manual / auto**
- 1-1/4" NPT vertical discharge
- Carbon/ceramic tandem seals
- Thermal sensors** (overload on 1 Ph)
- Moisture probes**
- Ductile iron vortex impeller
- Stainless steel cutter and plate (R-C 55-60)
- Stainless steel shaft
- Stainless steel lifting bail
- Corrosion-resistant, powder coated epoxy paint
- 20' (6 m) power cord - 20' (6 m) sensor cord
- cCSAus Certified

OPTIONS:

- Extended cord lengths
- Bronze vortex impeller
- Anti-siphon device

**requires circuit in control panel to function

C) VARIABLE LEVEL FLOAT SWITCHES

INDOOR SYSTEM

- 3 Switches and weights
- P/N 10-0347 WGT. 9.5 lb (4.3 kg)
- 4 Switches and weights
- P/N 10-0348 WGT. 13 lb (5.9 kg)

OUTDOOR SYSTEM

- Switches with pipe clamps, 3 required
- P/N 10-0744 20' WGT. 2 lb (kg)
- P/N 10-1878 35' WGT. 3 lb (kg)
- P/N 10-1879 50' WGT. 4.0 lb (kg)

D) JUNCTION BOXES - TYPE 4X

SIMPLEX

- 5 holes with seals for (1) power cord, (1) sensor cord, (3) float switch cords.
- P/N 10-0331 WGT. 2.5 lb (1.1 kg) 3-float system
- P/N 10-4508 Simplex J-box

DUPLEX

- 8 holes with seals for (2) power cords, (2) sensor cords, (3 or 4) float switch cords.
- P/N 10-0332 WGT. 2.5 lb (1.1 kg) 3-float system
- P/N 10-0421 WGT. 2.5 lb (1.1 kg) 4-float system
- P/N 10-4509 Duplex J-box

B) CONTROL PANELS						
SIMPLEX - NEMA 4 X				DUPLEX - NEMA 4X		
MODEL	P/N	WGT.		P/N	WGT.	
E or I840	<input type="checkbox"/> 10-0393	15 lb (6.8 kg)		<input type="checkbox"/> 10-0397	21 lb (9.5 kg)	
E or I840	<input type="checkbox"/> 10-0420*	17 lb (7.7 kg)		<input type="checkbox"/> 10-0512*	23 lb (10.4 kg)	
F or J840	<input type="checkbox"/> 10-0394	18 lb (8.2 kg)		<input type="checkbox"/> 10-0398	21 lb (9.5 kg)	
G840	<input type="checkbox"/> 10-0395	18 lb (8.2 kg)		<input type="checkbox"/> 10-0399	21 lb (9.5 kg)	
BA840	<input type="checkbox"/> 10-0396	18 lb (8.2 kg)		<input type="checkbox"/> 10-0400	21 lb (9.5 kg)	

*With Audible and Visible High Water Alarm

B) CONTROL PANEL STANDARD FEATURES:

- NEMA 4X outdoor rating
- Automatic reversing circuit
- Starting, control, and alarm circuits
- Thermal cut-out circuit (3 Ph only)
- Circuit breaker and rated motor contactor (1 Ph)
- Capacitors and motor starting relay on single phase
- Motor protective switch (circuit breaker / phase adjustable overloads) and rated motor contactor (3 Ph)
- Alternating circuit (duplex)
- High water alarm light
- Internal seal leak light
- HOA switches and pilot light(s)
- Terminal strips
- Padlock hasp

OPTIONS:

- Audible high water alarm
- Flasher for high water alarm light
- Manual reset of high water alarm
- Intrinsically-safe relays
- Elapsed time meters
- Dry auxiliary contact
- For other options, consult factory

SIMPLEX REVERSING CONTROL BOXES *						
AUTOMATIC			MANUAL			
MODEL	P/N	WGT.	P/N	WGT.		
E840	<input type="checkbox"/> 10-0352	8 lb (3.6 kg)	<input type="checkbox"/> 10-0360	7 lb (3.2 kg)		
I840	<input type="checkbox"/> 10-0352	8 lb (3.6 kg)	<input type="checkbox"/> 10-0360	7 lb (3.2 kg)		
F840	<input type="checkbox"/> 10-0353	6 lb (2.7 kg)	<input type="checkbox"/> 10-0361	5 lb (2.3 kg)		
J840	<input type="checkbox"/> 10-0353	6 lb (2.7 kg)	<input type="checkbox"/> 10-0361	5 lb (2.3 kg)		
G840	<input type="checkbox"/> 10-0353	12 lb (5.4 kg)	<input type="checkbox"/>	Not available		

*These control boxes consist of the reversing mechanisms and capacitors (1Ph units) only. They will not control pumps. Refer to Section B for complete system controls. For duplex applications use two simplex reversing control boxes.

E) INDOOR BASIN, COVER, AND HARDWARE PREPACKAGED STANDARD EQUIPMENT

- Fiberglass basin
- Rust-resistant steel cover (epoxy coated only)
- Inspection plate
- Individual pump covers
- 3" Adaptaflex vent seal
- 1-1/4" Adaptaflex discharge pipe seal(s)
- Cord seal(s)
- 1-4" rubber inlet pipe seal (field-installed)
- Pump support hardware
- 1-1/4" check valve(s)
- Ball valve(s)

SIMPLEX

- 24" x 36" (61 x 91 cm) P/N 32-0005 WGT. 107 lb (48.5 kg)

DUPLEX

- 30" x 36" (76 x 91 cm) P/N 32-0006 WGT. 154 lb (69.9 kg) 3-float system
- 30" x 36" (76 x 91 cm) P/N 32-0007 WGT. 154 lb (69.9 kg) 4-float system

F) OUTDOOR BASIN, COVER, AND RAIL SYSTEM

BASIN - STANDARD EQUIPMENT

- Fiberglass basin with anti-flotation ring
- 1.25" X 2" Z-Rail Disconnect System w/ 3/4" galvanized rail pipes
- 2" SCH. 80 PVC discharge pipe from disconnect
- 2" Flex boot discharge fitting
- Stainless steel lifting cable
- 2" PVC ball valve(s)
- 2" cast iron check valve(s)
- (1)-4" rubber inlet pipe seal (field-installed)
- Float Tree
- Blank Fiberglass cover with Zoeller imprint

SIMPLEX

<input type="checkbox"/> 24" x 48" (61 x 122 cm)	P/N 33-2054	WGT. 180 lb (93.4 kg)15"
<input type="checkbox"/> 24" x 60" (61 x 152 cm)	P/N 33-2057	WGT. 187 lb (99.3 kg)24"
<input type="checkbox"/> 24" x 72" (61 x 183 cm)	P/N 33-2060	WGT. 192 lb (105.7 kg)30"
<input type="checkbox"/> 24" x 84" (61 x 213 cm)	P/N 33-2063	WGT. 213 lb (119.7 kg)36"
<input type="checkbox"/> 24" x 96" (61 x 244 cm)	P/N 33-2069	WGT. 230 lb (125.6 kg)36"
<input type="checkbox"/> 24" x 108" (61 x 244 cm)	P/N 33-2075	WGT. 248 lb (125.6 kg)48"
<input type="checkbox"/> 24" x 120" (61 x 244 cm)	P/N 33-2078	WGT. 260 lb (125.6 kg)48"

DUPLEX

<input type="checkbox"/> 36" x 48" (91 x 122 cm)	P/N 33-2108	WGT. 258 lb (166.5 kg)19"
<input type="checkbox"/> 36" x 60" (91 x 152 cm)	P/N 33-2111	WGT. 272 lb (176.4 kg)24"
<input type="checkbox"/> 36" x 72" (91 x 183 cm)	P/N 33-2114	WGT. 285 lb (214.1 kg)30"
<input type="checkbox"/> 36" x 84" (91 x 213 cm)	P/N 33-2117	WGT. 304 lb (226.3 kg)36"
<input type="checkbox"/> 36" x 96" (91 x 244 cm)	P/N 33-2123	WGT. 332 lb (238.1 kg)36"
<input type="checkbox"/> 36" x 108" (91 x 244 cm)	P/N 33-2129	WGT. 359 lb (163 kg)48"
<input type="checkbox"/> 36" x 120" (91 x 244 cm)	P/N 33-2132	WGT. 379 lb (172 kg)48"

Note: 30" diameter simplex and 48" diameter Duplex system also available

H) RAIL SYSTEMS - (FIELD-INSTALLED)

Z-Rail Disconnect System for 1-1/4" pump discharges

(Rail System discharge is 2" NPT male thread)

Ductile Iron Constructions

P/N 39-0134 WGT. 43 lb (19.5 kg)

With Stainless Steel Upper Rail Support

P/N 39-0135 WGT. 43 lb (19.5 kg)

Intermediate Stabilizer Bracket for every 12' (3.7 m) of depth.

Stainless Steel

P/N 39-0139 WGT. 6 lb (2.7 kg)

I) CHECK VALVES

1-1/4" Cast iron NPT female

P/N 30-0163

WGT. 7.5 lb (3.4 kg)

1-1/2" Cast iron NPT female

P/N 30-0164

WGT. 7.5 lb (3.4kg)

2" Cast iron NPT female

P/N 30-0152

WGT. 10 lb (4.5 kg)

J) BALL VALVE

1-1/4" IPS

P/N 30-0165

WGT. 2 lb (0.9 kg)

1-1/2" IPS

P/N 30-0166

WGT. 2 lb (0.9 kg)

2" IPS

P/N 30-0167

WGT. 2.5 lb (1.1 kg)

G) STAINLESS STEEL LIFTING CABLE (Field-Installed Systems)

8' (2.4 m)

P/N 39-0031 WGT. 1 lb (0.5 kg)

12' (3.7 m)

P/N 39-0032 WGT. 1 lb (0.5 kg)

16' (4.9 m)

P/N 39-0033 WGT. 1 lb (0.5 kg)

FIELD-MOUNT SYSTEMS CHECKLIST

SIMPLEX		DUPLEX	
REQUIRED.	REQ.	REQUIRED.	REQ.
1 Grinder Pump	P/N ____ (A)	2 Grinders Pumps	P/N ____ (A)
1 Simplex control panel	P/N ____ (B)	1 Duplex control panel	P/N ____ (B)
3 Float Switches	P/N ____ (C)	3 or 4 Float Switches	P/N ____ (C)
1 Junction box (optional)	P/N ____ (D)	1 Junction box (optional)	P/N ____ (D)
1 Rail system	P/N ____ (H)	2 Rail systems	P/N ____ (H)
1 Stainless steel lifting cable	P/N ____ (G)	2 Stainless steel lifting cables	P/N ____ (G)
1 Check valve	P/N ____ (I)	2 Check valves	P/N ____ (I)
1 Ball valve	P/N ____ (J)	2 Ball valves	P/N ____ (J)

PREPACKAGED AND JOB READY SYSTEMS CHECKLIST

INDOOR			
SIMPLEX		DUPLEX	
REQ.	REQ.	REQ.	REQ.
1 Grinder Pump	P/N ____ (A)	2 Grinders Pumps	P/N ____ (A)
1 Simplex control panel	P/N ____ (B)	1 Duplex control panel	P/N ____ (B)
1 Float Switch Asm.	P/N ____ (C)	1 Float Switch Asm.	P/N ____ (C)
1 Basin, cover and hardware	P/N ____ (E)	1 Basin, cover and hardware	P/N ____ (E)
OUTDOOR			
SIMPLEX		DUPLEX	
REQ.	REQ.	REQ.	REQ.
1 Grinder Pump	P/N ____ (A)	2 Grinders Pumps	P/N ____ (A)
1 Simplex control panel	P/N ____ (B)	1 Duplex control panel	P/N ____ (B)
3 Float Switches	P/N ____ (C)	3 or 4 Float Switches	P/N ____ (C)
1 J-box (optional)	P/N ____ (D)	1 J-box (optional)	P/N ____ (D)
1 Basin, cover and hardware	P/N ____ (F)	1 Basin, cover and hardware	P/N ____ (F)