

LOW LEAD COMPLIANT 4-1/2" CONTRACTOR'S GAUGE

The contractor's gauge is designed for a wide variety of industrial applications, but is especially suited for heating and air conditioning systems. The rugged gauge case is made of stainless steel to provide the protection needed in corrosive atmospheres. Connection and wetted internal components meet Federal lead free requirements.

Features:

- Dual Scale (PSI and kPa)
- +/- 1% Grade 1A Per ANSI/ASME B40.100
- Complies with Federal Lead-Free Law (Sec. 1417)
- 304SS Case and Bezel Ring
- Zero Adjustment Screw
- Lead Free Phosphor Bronze Bourdon Tube
- 1/4" Lead Free Brass MNPT Connection
- Brass Movement
- Black Anodized Aluminum Pointer
- White Aluminum Dial with Black and Red Markings
- Lead Free Silver Solder Welding
- Acrylic Lens
- 75% of Full Scale Working Pressure
- 25% Over-Pressure Limit
- -40°F to 150°F (-40°C to 65°C) Process and Ambient Temperature Limit
- IP52 Enclosure Rating

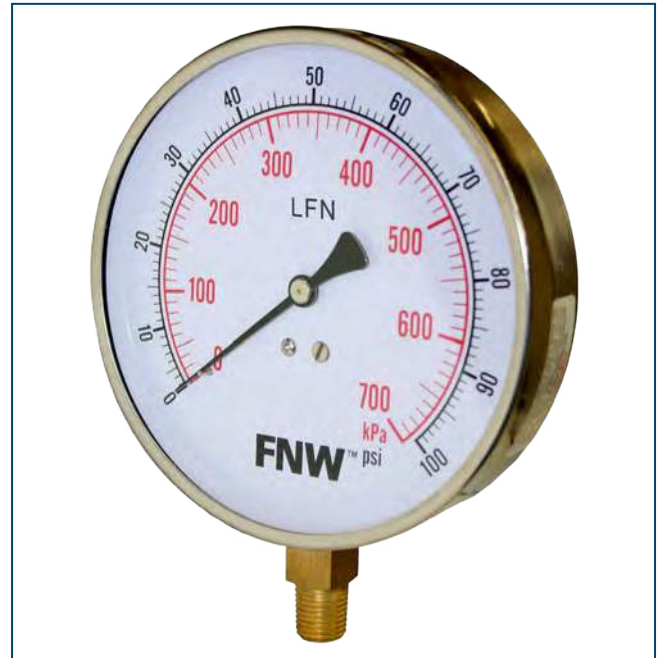

Low Lead Compliant: Referring to laws defining "Lead Free" as wetted surface of pipe, fittings and fixtures in potable water systems that have a weighted average lead content $\leq 0.25\%$ per the Safe Drinking Water Act (Sec. 1417) amended 1-4-2011 as well as other state regulations.



Dial Resolution

Range (PSI)	PSI Per Mark
0 to 30	0.5
0 to 60, 100	1
0 to 160, 200	2
0 to 300	5

Part Numbers

Range (PSI)	Part Number
0 to 30	FNWXG030R
0 to 60	FNWXG060R
0 to 100	FNWXG0100R
0 to 160	FNWXG0160R
0 to 200	FNWXG0200R
0 to 300	FNWXG0300R

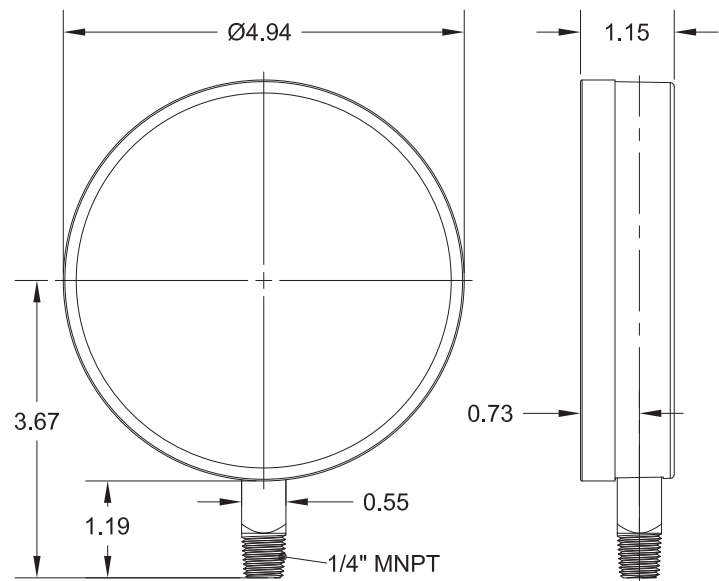

DOC: FNWXG13 Ver. 10/2013

© 2013 - FNW. All rights reserved.

The FNW logo is a trademark of Ferguson Enterprises, Inc., PL Sourcing, PO Box 2778, Newport News, VA 23609

www.fnw.com

The contents of this publication are presented for information purposes only, and while effort has been made to ensure their accuracy, they are not to be construed as warranties or guarantees, expressed or implied, regarding the products or services described herein or their use or applicability. All sales are governed by our terms and conditions, which are available on request. We reserve the right to modify or improve the designs or specifications of our products at any time without notice. Always verify that you have the most recent product specifications or other documentation prior to the installation of these products.