

SPECIFICATION SUBMITTAL SHEET

jones stephens corporation

FLEXIBLE FLOOR AND CEILING PLATES

PART NO. F06-150

features and benefits:

- Never rusts or corrodes
- Can be painted

This product and others like it can be found in the Jones Stephens catalog. Call today to order your catalog or download it from our website: www.plumbest.com

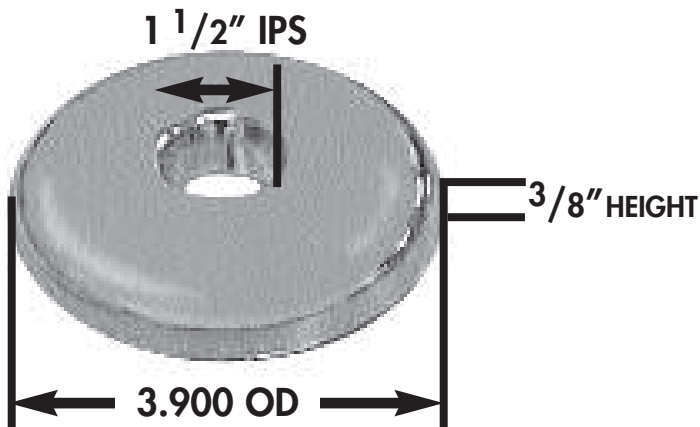

PART NO.

□ F06-150

DESCRIPTION

CHROME PLATED PLASTIC

jones stephens corporation

3249 moody parkway • moody, alabama 35004

toll free phone: 1-800-355-6637 • toll free fax: 1-800-462-6991

www.plumbest.com