

Mushroom Cabinet Knob 1.25" 5-Pack
Satin Nickel

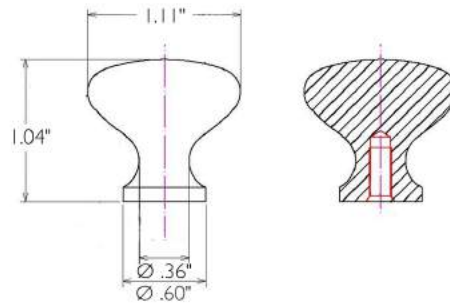

SPECIFICATIONS

MATERIAL CONSTRUCTION:	Zinc
MOUNTING HARDWARE INCLUDED:	Yes
TOOLS NEEDED FOR INSTALLATION:	Screwdriver
ASSEMBLED DIMENSIONS:	1.04" H x 1.11" L
CENTER TO CENTER:	N/A
LEVER/PULL LENGTH:	N/A
PROJECTION:	1.04"
KNOB DIAMETER:	1.11"
ASSEMBLED WEIGHT:	0 lbs.

WARRANTY: 1-Year limited warranty
LEGAL FOR SALE IN CALIFORNIA: Yes



TYPE:
JOB:
ORDER CODE:
APPROVALS: