

# SELECTRONIC® SENSOR OPERATED URINAL FLUSH VALVE

## HARD-WIRED AC POWER, BASE MODEL

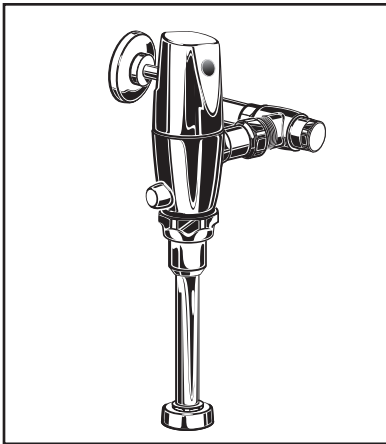

### GENERAL DESCRIPTION:

Exposed, Sensor Operated Selectronic® Urinal Flush Valve for 3/4" top spud urinals.

Inlet includes 3/4" I.P.S. angle stop with back-flow protection, vandal-resistant cap, sweat solder kit, cover tube and wall flange.

Outlet includes 3/4" vacuum breaker, spud coupling and flange.

### PRODUCT FEATURES:

- **Pressure Compensation** feature ensures accurate flush volume regardless of inlet water pressure
- **Self-Cleaning Piston** with integral wiper spring significantly reduces clogging and maintenance
- **No Routine Maintenance:** no diaphragms to replace; no filters to clean
- **Optional Cover Plate** for transformer installation from the front
- **Selectronic® Proximity System** with universal sensor provides hygienic, "hands free" operation
- **State-of-the-Art Electronics** prevent ghost flushing
- **Dezincification Resistant** semi-red brass alloy
- **Fully Mechanical Manual Override Button** can flush the valve without power
- **Fail-Safe:** Valve automatically closes upon loss of power or water pressure and does not need to be reset
- **Adjustable Sanitary Flush** cleans the fixture & maintains the trap seal.
- **Stadium Feature:** Valve automatically switches to water savings mode during periods of heavy usage
- **Chemical Resistant EPDM Seals** for extended life
- **High Back Pressure Vacuum Breaker**
- **Adjustable Tailpiece**
- **Range can be adjusted manually or with optional remote control**
- **No external volume adjustment.**
- **Can be installed left or right handed**

### BASE MODEL: (Does Not include Power Supply)

- 606B.101** Base Model, 1.0 gpf  
For use with Hard-Wired AC or Multi-AC power kits. 11-1/2" rough-in
- 606B.051** Base Model, 0.5 gpf  
**SAME AS ABOVE**
- 606B.025** Base Model, 0.25 gpf  
**SAME AS ABOVE**
- 606B.013** Base Model, 0.125 gpf  
**SAME AS ABOVE**



### POWER KITS: (Must be Purchased Separately)

- PK00.HAC** Hard-Wired AC transformer, 10' extension cable and capacitor module
- PK00.MAC** Multi-AC adapter and 10" extension cable

### OPERATING PRESSURE:

20 psi (flowing) - 80 psi (static)

### FLOW REQUIREMENT:

10 gpm (37.9 L/min.)

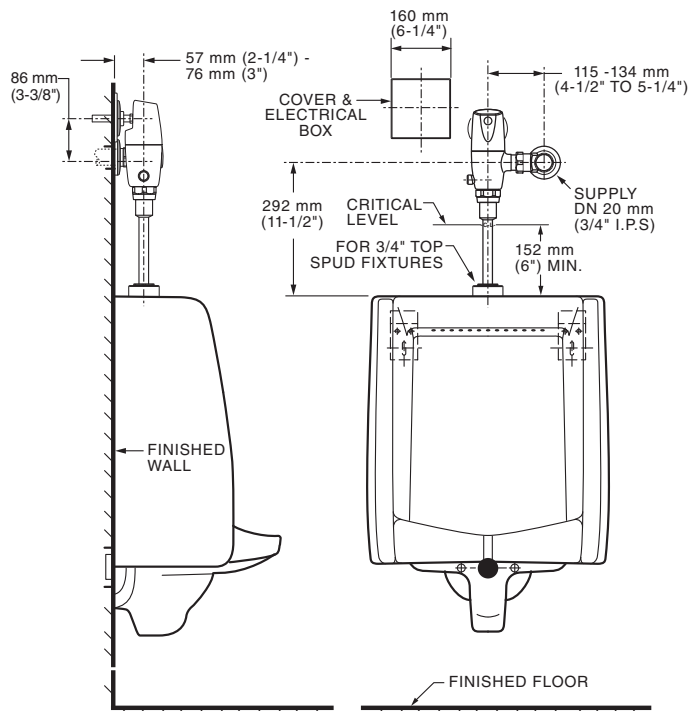

### RECOMMENDED SPECIFICATION:

Electronic proximity infrared sensor activated toilet flush valve shall feature self-cleaning piston valve. Includes a fully mechanical manual over-ride that can provide a complete flush without power. Includes cast brass valve body and metal cover with chrome finish and vandal resistant stop cap. Angle stop with back-flow protection and vacuum breaker included. Flush valve shall be American Standard Model # 606B.\_\_\_\_.002

**LISTINGS:**

- ASSE 1037
- ANSI/ASME A112.19.2
- ADA Compliant

**Roughing-in Dimensions**

