

## HINGED SPLIT RING

### Features

- Finish: Plain, Zinc, Epoxy Copper
- MSS SP-58, type 12
- Material: Malleable Iron, ASTM A47 Grade 32510

- A - Rod size (hanger rod and nuts not included)
- B - Center of pipe to top of hanger
- C - Width of hanger

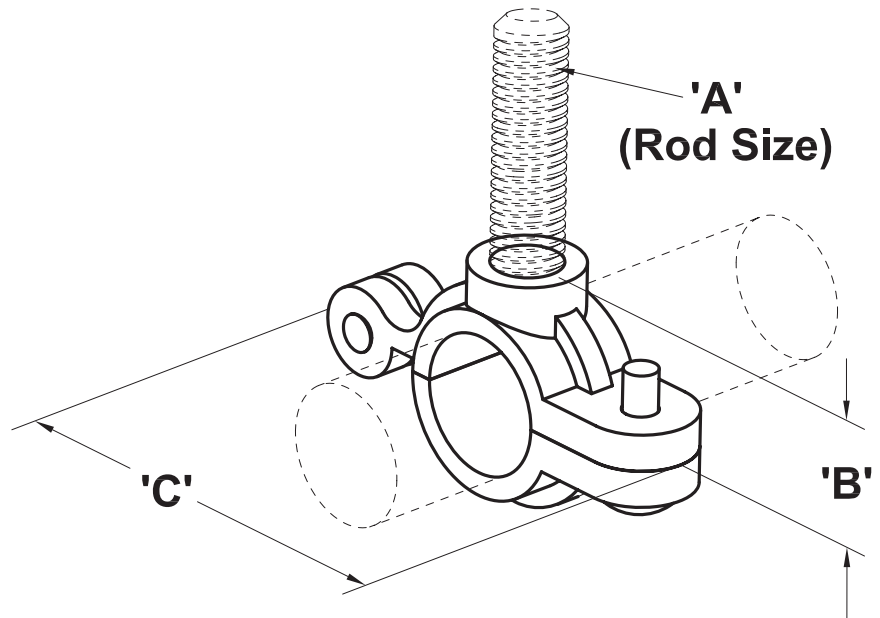

Pipe Size		A (Rod Size)	B (in.)		Pipe Size		C (in.)		Max. Load Lbs.	Weights (oz.)	
in.	mm		Plain & Zinc	Epoxy Copper	in.	mm	Plain & Zinc	Epoxy Copper		Plain & Zinc	Epoxy Copper
3/8	17.2	3/8"-16	0.66	0.66	3/8	17.2	2.06	1.78	180	1.66	1.34
1/2	21.3	3/8"-16	0.75	0.75	1/2	21.3	2.22	1.97	180	1.76	1.62
3/4	26.6	3/8"-16	0.84	0.84	3/4	26.6	2.50	2.25	180	2.08	1.80
1	33.4	3/8"-16	0.97	0.97	1	33.4	2.75	2.44	180	2.36	2.08
1-1/4	42.1	3/8"-16	1.16	1.13	1-1/4	42.1	3.22	2.78	180	3.10	2.40
1-1/2	48.2	3/8"-16	1.28	1.25	1-1/2	48.2	3.44	3.06	180	3.46	2.82
2	60.3	3/8"-16	1.53	1.47	2	60.3	3.94	3.53	180	4.41	3.77
2-1/2	73.0	1/2"-13	1.94	1.88	2-1/2	73.0	4.75	4.44	300	7.65	6.81
3	88.9	1/2"-13	2.56	2.16	3	88.9	5.38	4.94	300	9.17	7.51
4	114.3	1/2"-13	2.75	2.63	4	114.3	6.41	5.94	300	10.58	9.28

Pipe Size		Catalog Number		
in.	mm	Plain	Zinc	Epoxy Copper
3/8	17.2	FNW7001PC	FNW7001ZC	FNW7001ECC
1/2	21.3	FNW7001PD	FNW7001ZD	FNW7001ECD
3/4	26.6	FNW7001PF	FNW7001ZF	FNW7001ECF
1	33.4	FNW7001PG	FNW7001ZG	FNW7001ECG
1-1/4	42.1	FNW7001PH	FNW7001ZH	FNW7001ECH
1-1/2	48.2	FNW7001PJ	FNW7001ZJ	FNW7001ECJ
2	60.3	FNW7001PK	FNW7001ZK	FNW7001ECK
2-1/2	73.0	FNW7001PL	FNW7001ZL	FNW7001ECL
3	88.9	FNW7001PM	FNW7001ZM	FNW7001ECM
4	114.3	FNW7001PP	FNW7001ZP	FNW7001ECP