

Grade A, Zinc

Specification: ASME B18.5

Bolts less than or equal to 6" in length shall be fully threaded
 Bolts longer than 6" shall have 6" of fully formed threads

Material & Mechanical Properties: Grade A per ASTM A307

Thread Requirements: ASME B1.1, UNC

Finish: Fe/Zn 3AN per ASTM F1941/F1941M

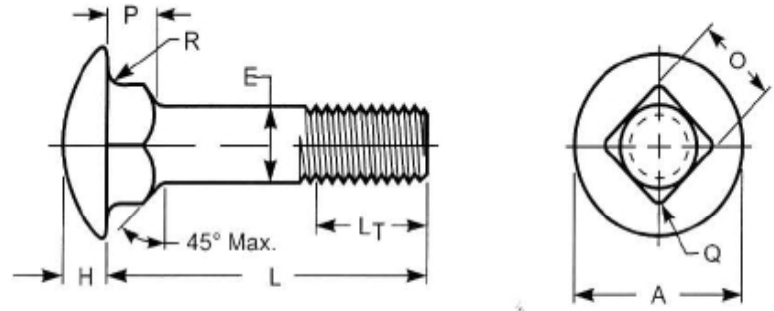

Nominal Size or Basic Bolt Diameter	E		A		H		O		P		Q	R	
	Body Diameter (in)		Head Diameter (in)		Head Height (in)		Square Width (in)		Square Depth (in)		Corner Radius on Square (in)	Fillet Radius (in)	
	Max	Min	Max	Min	Max	Min	Max	Min	Max	Min	Max	Max	
3/8	0.375	0.388	0.329	0.844	0.782	0.208	0.188	0.388	0.368	0.219	0.188	0.047	0.031
1/2	0.500	0.515	0.444	1.094	1.032	0.270	0.250	0.515	0.492	0.281	0.250	0.047	0.031

SKU	Diameter (in)	L	Pack Qty
		Nominal Length	
FNWCBZ381	3/8	1	10
FNWCBZ38112		1-1/2	10
FNWCBZ383		3	10
FNWCBZ384		4	10
FNWCBZ123	1/2	3	4
FNWCBZ124		4	4
FNWCBZ125		5	4
FNWCBZ127		7	4