

# Victaulic Balancing Valves

## TA Series 786/787H/788/789 and Series 78KH



08.16



### 1.0 PRODUCT DESCRIPTION

#### Available Sizes

- ½ – 16"/DN15 – DN400

#### Maximum Working Pressure

- Series 786: 300 psi/2068 kPa/20.7 bar
- Series 787H and Series 78KH: 400 psi/2758 kPa/27.6 bar
- Series 788: 250 psi/1724 kPa/17.2 bar
- Series 789: 350 psi/2413 kPa/24 bar

#### Operating Temperature

- -4°F to +248°F/-20°C to +120°C

#### Application

- Heating (not including steam) and cooling systems

#### Function

- Balancing
- Pre-Setting
- Measuring
- Shut-Off
- Draining (depending on valve type)

### 2.0 CERTIFICATION/LISTINGS

Not applicable – contact Victaulic with any questions.

ALWAYS REFER TO ANY NOTIFICATIONS AT THE END OF THIS DOCUMENT REGARDING PRODUCT INSTALLATION, MAINTENANCE OR SUPPORT.

System No.		Location	
Submitted By		Date	

Spec Section		Paragraph	
Approved		Date	



### 3.0 SPECIFICATIONS – MATERIAL

---

#### TA Series 786 & 787H and Series 78KH

**Valve Body and Bonnet:** AMETAL® dezincification resistant (DZR) brass alloy

**Sealing (Body/Bonnet):** EPDM O-ring

**Valve Plug:** AMETAL®

**Seat Seal:** EPDM O-ring

**Spindle:** AMETAL®

**Slip Washer:** Polytetrafluoroethylene (PTFE)

**Spindle Seal:** EPDM O-ring

**Spring:** Stainless steel

**Hand Wheel:** Polyamide and TPE

**Measuring Points:** AMETAL®

**Measuring Point Seals:** EPDM

**Measuring Point Caps:** Polyamide and TPE

**Drain Kit Body:** AMETAL®

**Drain Kit Seals:** EPDM

**Drain Kit Gasket:** Fiber-based aramid

#### TA Series 788 & 789

**Body:** Ductile iron conforming to ASTM A536 Grade 60-40-18 (BS Grade 400/15)

**Body Coating:** 2 ½ – 8" – Epoxy painted; 10 – 16" – Painted

#### Trim (Bonnet, Stem and Restriction Cone)

- Bonnet: 2 ½ – 6" – AMETAL®; 8 – 16" – Ductile iron
- 2 ½ – 6" Stem & Restriction Cone: AMETAL®
- 8 – 16" Cone – Ductile iron; 8 – 16" Spindle – AMETAL®

**Seat:** Ductile iron

**Seat Seal:** EPDM

**Stem Seal:** EPDM

**Probe Seal:** EPDM

**Handwheel:** 2 ½ – 6" – Red polyamide plastic; 8 – 16" – Aluminum

**Optional Equipment:** 2 ½ – 6" Series 789 only – Insulation kit, polyurethane

#### Allen Wrench Sizes

- ½ – 2" Series 786, 787H and 78KH: 3 mm memory
- 2 ½ – 12" Series 788 & 2 ½ – 6" Series 789: 5 mm memory
- 8 – 16" Series 789: 8 mm memory

#### NOTE

- AMETAL® is the dezincification-resistant brass alloy of IMI TA

## 4.0 DIMENSIONS

### TA Series 786 Solder End

### TA Series 787H Female Threaded End

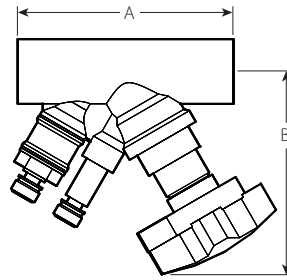

TA Series 786  
½ – 2"/DN15 – DN50

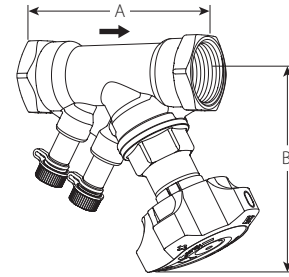

TA Series 787H  
½ – 2"/DN15 – DN50

Size		TA Series 786 Solder End (300 psi/2068 kPa)			TA Series 787H NPT Female Threaded End (400 psi/2758 kPa)		
Nominal inches DN	Actual Outside Diameter inches mm	A End to End inches mm	B Center to Top inches mm	Approx. Weight Each lb kg	A End to End inches mm	B Center to Top inches mm	Approx. Weight Each lb kg
½ DN15	0.840 21.3	3.50 89	4.00 102	1.4 0.6	3.31 84	4.00 102	1.5 0.7
¾ DN20	1.050 26.9	3.81 97	4.00 102	1.4 0.6	3.70 94	4.00 102	1.6 0.7
1 DN25	1.315 33.7	4.31 110	4.50 114	1.9 0.9	4.13 105	4.13 105	2.0 0.9
1 ¼ DN32	1.660 42.4	4.88 124	4.31 110	2.4 1.1	4.76 121	4.13 105	2.6 1.2
1 ½ DN40	1.900 48.3	5.13 130	4.75 121	3.1 1.4	4.96 126	4.75 121	3.3 1.5
2 DN50	2.375 60.3	6.13 156	4.75 121	4.5 2.0	6.10 155	4.75 121	5.0 2.3

## 4.1 DIMENSIONS

### Series 78KH Male NPT Union x FEM NPT

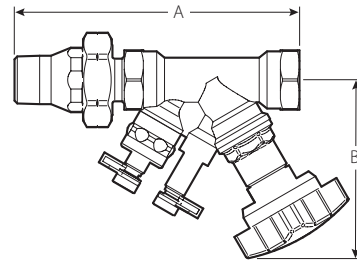

Series 78KH  
1/2 – 2"/DN15 – DN50

Size				Series 78KH Male NPT Union x FEM NPT (400 psi/2758 kPa)				
Nominal inches mm		Actual Outside inches mm		A End to End inches mm	B Center to Top inches mm	Approx. Weight Each lb kg		
MPT Union	FPT Valve	MPT Union	FPT Valve					
1/2 DN15	x	1/2 DN15	0.840 21.3	x	0.840 21.3	5.56 141	4.00 102	1.7 0.8
		3/4 DN20			1.050 26.9	5.83 148	4.00 102	1.8 0.8
		1 DN25			1.315 33.7	6.09 155	4.13 105	2.7 1.2
		1 1/4 DN32			1.660 42.4	7.25 184	4.13 105	4.1 1.9
3/4 DN20	x	3/4 DN20	1.050 26.9	x	1.050 26.9	5.88 149	4.00 102	2.3 1.0
		1 DN25			1.315 33.7	6.63 168	4.13 105	2.2 1.0
		1 1/4 DN32			1.660 42.4	7.50 190	4.13 105	4.3 1.9
		1 1/2 DN40			1.900 48.3	7.50 190	4.75 121	5.0 2.3
1 DN25	x	1 DN25	1.315 33.7	x	1.315 33.7	7.52 191	4.13 105	4.02 1.8
		1 1/4 DN32			1.660 42.4	7.65 194	4.13 105	2.8 1.3
		1 1/2 DN40			1.900 48.3	7.50 190	4.75 121	5.2 2.4
		2 DN50			2.375 60.3	8.88 226	4.75 121	7.3 3.3
1 1/4 DN32	x	1 1/4 DN32	1.660 42.4	x	1.660 42.4	8.06 205	4.13 105	5.52 2.5
		1 1/2 DN40			1.900 48.3	8.04 204	4.75 121	3.6 1.6
		2 DN50			2.375 60.3	8.88 226	4.75 121	7.5 3.4
1 1/2 DN40	x	1 1/2 DN40	1.900 48.3	x	1.900 48.3	8.83 224	4.75 121	7.16 3.2
		2 DN50			2.375 60.3	8.99 228	4.75 121	5.3 2.4
2 DN50	x	2 DN50	2.375 60.3	x	2.375 60.3	8.86 225	4.75 121	7.19 3.3

**NOTE**

- Optional tailpiece options are available. See accessory table on pg. 5 for more information.

## 4.2 OPTIONAL PARTS

### Series 78Y/78U/78K Union Tailpieces (Optional)



Female Tailpiece

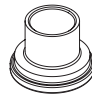

Sweat Tailpiece

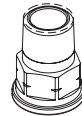

Male Tailpiece

Size		Victaulic Part Code		
Nominal inches		Female Tailpiece	Sweat Tailpiece	Male Tailpiece
1/2	x 1/2	P00478Y304	P00478Y504	P00478U404
3/4	x 1/2	P00678Y304	P00678Y504	P00678U404
		P00678Y306	P00678Y506	P00678U406
1	x 1/2	P00678Y304	P00678Y504	P00678U404
		P00678Y306	P00678Y506	P00678U406
		P00678Y310	P00678Y510	P00678U410
1 1/4	x 1/2	–	–	P01278U404
		P01278Y306	P01278Y506	P01278U406
		P01278Y310	P01278Y510	P01278U410
		P01278Y312	P01278Y512	P01278U412
1 1/2	x 1/2	–	–	P01278U404
		P01278Y306	P01278Y506	P01278U406
		P01278Y310	P01278Y510	P01278U410
		P01278Y312	P01278Y512	P01278U412
		P01278Y314	P01278Y514	P01278U414
2	x 1	–	–	P02078U410
		P02078Y312	P01278Y512	P02078U412
		P02078Y314	P01278Y514	P02078U414
		P02078Y320	P02078Y520	P02078U420

### 4.3 DIMENSIONS

**TA Series 788** Flanged End  
(Class 150 RF, ASME/ANSI B16.42)

**TA Series 789** Grooved End

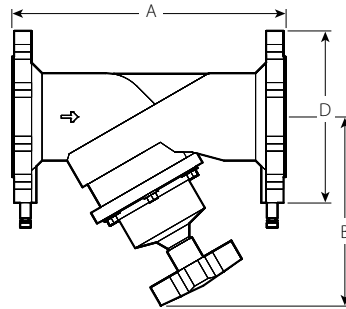

TA Series 788  
2 ½ – 16"/73.0 mm – DN400

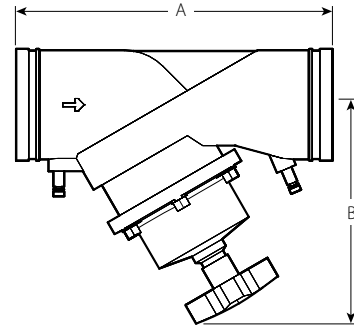

TA Series 789  
2 ½ – 12"/73.0 mm – DN300

Size		TA Series 788 Flanged End (250 psi/1724 kPa)				TA Series 789 Grooved End (350 psi/2413 kPa)		
Nominal inches DN	Actual Outside Diameter inches mm	A End to End inches mm	B Center to Top inches mm	D inches mm	Approx. Weight Each lb kg	A End to End inches mm	B Center to Top inches mm	Approx. Weight Each lb kg
2 ½	2.875 73.0	11.42 290	8.07 205	7.09 180	24.0 10.9	11.38 289	8.00 203	14.0 6.4
3 DN80	3.500 88.9	12.20 310	8.66 220	7.48 190	31.0 14.1	12.25 311	8.63 219	20.0 9.1
4 DN100	4.500 114.3	13.78 350	9.45 240	9.06 230	43.0 19.6	13.75 350	9.44 240	31.0 14.1
5 DN125	5.563 141.3	15.75 425	10.83 275	10.04 255	62.0 28.5	15.75 400	10.88 276	50.0 22.7
6 DN150	6.625 168.3	18.90 480	11.22 285	11.02 280	82.0 37.5	18.88 480	11.25 286	69.0 31.3
8 DN200	8.625 219.1	23.62 600	16.93 430	13.58 345	168.0 76.5	23.63 600	17.00 432	140.0 63.7
10 DN250	10.750 273.0	28.74 730	16.54 420	15.98 406	270.0 122.9	28.75 730	17.75 451	202.0 91.9
12 DN300	12.750 323.9	33.46 850	18.90 480	19.02 483	360.0 163.9	33.50 851	19.00 483	280.0 127.4
14 DN350	14.000 355.6	38.58 982	23.03 585	20.98 533	655.0 297.0	-	-	-
16 DN400	16.000 406.4	43.31 1100	25.20 640	23.50 597	895.0 406.0	-	-	-

## 5.0 PERFORMANCE

### Valve Selection Guide – TA Series 786 & 787H and Series 78KH

Size		Flow Data for TA Series 786/787H/78KH		
Nominal inches DN	Actual Outside Diameter inches mm	Absolute Min. Flow GPM LPM	Nominal Range of Flow GPM LPM	Absolute Max. Flow GPM LPM
½ DN15	0.840 21.3	0.1 0.5	0.6 – 2.8 2.3 – 10.6	8.6 32.6
¾ DN20	1.050 26.9	0.4 1.5	2.0 – 6.0 7.6 – 22.7	20.0 76.0
1 DN25	1.315 33.7	0.5 1.7	3.9 – 10.0 14.8 – 37.9	30.0 114.0
1 ¼ DN32	1.660 42.4	0.9 3.3	5.0 – 15.0 18.9 – 56.8	48.0 182.0
1 ½ DN40	1.900 48.3	1.3 4.9	6.6 – 20.0 25.0 – 75.7	66.0 250.0
2 DN50	2.375 60.3	2.0 7.6	12.6 – 36.0 47.7 – 136.0	110.0 416.0

#### Important Notes

Balancing valves should be sized in accordance with the GPM/LPM flows (and not in relation to pipeline size). Sizing balancing valves based on the minimum or maximum flow rates is not recommended. Valves should be sized using the nominal flow rate only. The Minimum Flow is calculated from the minimum open setting of the valve and a minimum pressure drop 1 Ft. WG (= 3 kPa). The Nominal Flow is calculated from the maximum open setting of the valve and the minimum recommended pressure drop, 2 Ft. WG (= 6 kPa). The Maximum Flow is calculated from the maximum open setting of the valve and the maximum pressure drop, 20 Ft. WG (= 60 kPa). A computer program, TA-Select, is available for calculation of valve handwheel pre-set position and other applications.

#### NOTE

- For information regarding Allen Wrench sizes see section 3.0 Material Specifications.

#### Measuring Accuracy

The hand wheel zero position is calibrated and must not be changed. Valves have an accuracy of flow measurement of 2% to 3% when used within their recommended flow range and installed in accordance with the figure below.

#### NOTE

- For the most accurate results, a Series 734 TA SCOPE or Series 73M CMI should be used. However, any differential pressure meter may be used.

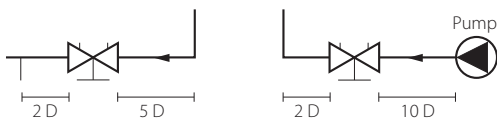

The illustration relates to the accuracy of differential pressure measurement and is not an installation requirement.

## 5.1 PERFORMANCE

### C<sub>v</sub> Values for Various Handle Settings

#### TA Series 786

The values below may be used when calculating and sizing a piping system.

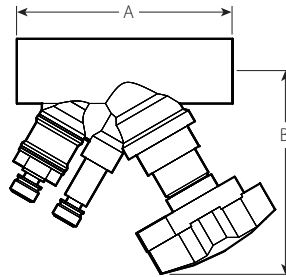

TA Series 786

C <sub>v</sub> Values for Sizes listed below <sup>1</sup>						
No. of Turns	½"	¾"	1"	1 ¼"	1 ½"	2"
0.50	0.15	0.59	0.70	1.32	2.03	2.97
1.00	0.25	0.88	1.19	2.20	3.83	4.87
1.50	0.36	1.38	2.44	3.60	5.34	8.35
2.00	0.66	2.20	4.20	5.41	7.08	13.60
2.50	1.02	3.25	6.15	8.24	10.20	18.80
3.00	1.60	4.49	8.00	11.00	14.60	24.90
3.50	2.30	5.51	9.28	13.70	18.60	30.70
4.00 <sup>2</sup>	2.92	6.61	10.10	16.50	22.30	38.30

<sup>1</sup> C<sub>v</sub> = GPM at a ΔP of 1 psi/7 kPa) through the valve at any given setting.  
1 psi = 2.31 ft. of H<sub>2</sub>O

<sup>2</sup> Full open valve.

#### TA Series 787H and Series 78KH

The values below may be used when calculating and sizing a piping system.

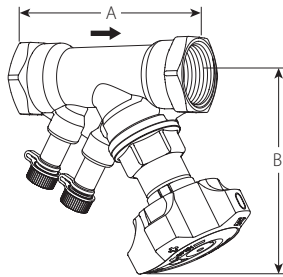

TA Series 787H

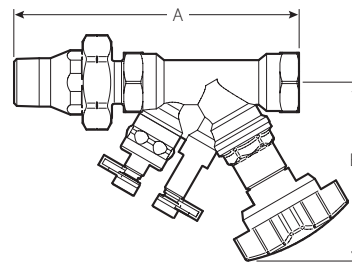

TA Series 78KH

C <sub>v</sub> Values for Sizes listed below <sup>1</sup>						
No. of Turns	½"	¾"	1"	1 ¼"	1 ½"	2"
0.50	0.157	0.616	0.693	1.38	2.19	3.03
1.00	0.261	0.903	1.19	2.42	3.93	4.74
1.50	0.401	1.41	2.46	3.88	5.48	7.82
2.00	0.714	2.25	4.21	6.03	7.23	13.2
2.50	1.08	3.13	6.08	8.98	10.6	18.3
3.00	1.69	4.29	7.69	11.4	14.8	24.9
3.50	2.39	5.21	9.01	13.8	18.7	31.2
4.00 <sup>2</sup>	2.96	6.23	9.93	16.4	22.3	37.3

<sup>1</sup> C<sub>v</sub> = GPM at a ΔP of 1 psi/7 kPa) through the valve at any given setting.  
1 psi = 2.31 ft. of H<sub>2</sub>O

<sup>2</sup> Full open valve.



## 5.2 PERFORMANCE

### Valve Selection Guide – TA Series 788 & 789

Size		Flow Data for TA Series 788 & 789		
Nominal inches DN	Actual Outside Diameter inches mm	Absolute Min. Flow GPM LPM	Nominal Range of Flow GPM LPM	Absolute Max. Flow GPM LPM
2 1/2	2.875 73.0	1.4 5.3	38.0 – 100.0 144.0 – 379.0	290.0 1097.7
3 DN80	3.500 88.9	1.5 5.7	31.0 – 130.0 117.0 – 493.0	410.0 1551.9
4 DN100	4.500 114.3	1.9 7.2	68.0 – 200.0 257.0 – 757.0	650.0 2460.3
5 DN125	5.563 141.3	4.2 15.9	90.0 – 320.0 341.0 – 1211.0	1020.0 3860.7
6 DN150	6.625 168.3	5.0 18.9	182.0 – 450.0 689.0 – 1703.0	1430.0 5412.6
8 DN200	8.625 219.1	30.0 113.6	367.0 – 820.0 1389.0 – 3104.0	2600.0 9841.0
10 DN250	10.750 273.0	70.0 265.0	540.0 – 1300.0 2044.0 – 4921.0	4040.0 15291.4
12 DN300	12.750 323.9	115.0 435.3	960.0 – 1500.0 3634.0 – 5678.0	4950.0 18735.8
14 <sup>3</sup> DN350	14.000 355.6	83.0 314.0	1020.0 – 2700.0 3861.0 – 10220.0	7414.0 28062.0
16 <sup>3</sup> DN400	16.000 406.4	95.0 360.0	1330.0 – 3400.0 5034.0 – 12869.0	9371.0 35469.0

<sup>3</sup> Only the TA Series 788 Flanged End Balancing Valves is available in 14 – 16"/DN350 – DN400 sizes.

#### Important Notes

Balancing valves should be sized in accordance with the GPM/LPM flows (and not in relation to pipeline size). Sizing balancing valves based on the minimum or maximum flow rates is not recommended. Valves should be sized using the nominal flow rate only. The Minimum Flow is calculated from the minimum open setting of the valve and a minimum pressure drop 1 Ft. WG (= 3 kPa). The Nominal Flow is calculated from the maximum open setting of the valve and the minimum recommended pressure drop, 2 Ft. WG (= 6 kPa). The Maximum Flow is calculated from the maximum open setting of the valve and the maximum pressure drop, 20 Ft. WG (= 60 kPa). A computer program, TA-Select, is available for calculation of valve handwheel pre-set position and other applications.

#### NOTES

- For information regarding Allen Wrench sizes, see section 3.0 Material Specifications.
- For the most accurate results, a Series 734 TA SCOPE or Series 73M CMI should be used. However, any differential pressure meter may be used.

### 5.3 PERFORMANCE

#### C<sub>v</sub> Values for Various Handle Settings

#### TA Series 788 & 789

The values below may be used when calculating and sizing a piping system.

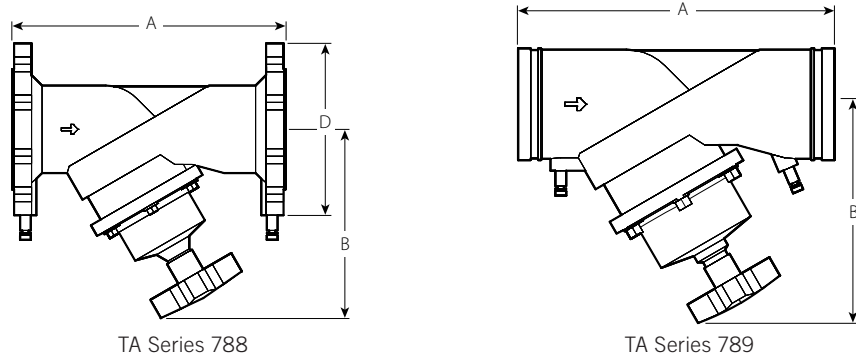

C <sub>v</sub> Values for Sizes listed below <sup>4</sup>										
No. of Turns	2 ½"	3"	4"	5"	6"	8"	10"	12"	14" <sup>5</sup>	16" <sup>5</sup>
0.50	2.09	2.32	2.90	6.38	7.54	–	–	–	–	–
1.00	3.94	4.64	6.96	12.20	13.90	–	–	–	–	–
1.50	5.68	6.96	10.40	18	25.50	–	–	–	–	–
2.00	7.54	9.28	13.30	24.90	46.40	46.40	104	–	–	–
2.50	10.80	12.80	18.60	31.30	75.40	58	128	–	–	–
3.00	18.90	16.20	30.20	41.80	116	75.40	162	174	126	145
3.50	29.70	22.60	51	63.80	157	104	226	267	150	172
4.00	40.90	33.60	73.10	96.30	196	139	296	348	172	198
4.50	51.60	47.60	92.80	132	240	191	371	429	197	241
5.00	60.30	63.80	114	164	281	261	447	522	240	306
5.50	70.20	78.90	133	194	324	331	516	621	295	378
6.00	78.90	92.80	153	229	362	394	580	719	350	448
6.50	84.70	107	168	255	394	464	632	800	408	521
7.00	89.30	119	184	289	426	505	684	870	469	597
7.50	93.40	131	203	320	454	545	766	945	546	684
8.00	98.60 <sup>6</sup>	139 <sup>6</sup>	220 <sup>6</sup>	348 <sup>6</sup>	487 <sup>6</sup>	597	841	1032	645	789
9.00	–	–	–	–	–	690	951	1125	909	1037
10.00	–	–	–	–	–	754	1090	1206	1110	1322
11.00	–	–	–	–	–	824	1218	1299	1276	1450
12.00	–	–	–	–	–	887 <sup>6</sup>	1375 <sup>6</sup>	1392	1462	1624
13.00	–	–	–	–	–	–	–	1531	1647	1810
14.00	–	–	–	–	–	–	–	1589	1868	2007
15.00	–	–	–	–	–	–	–	1624	2042	2250
16.00	–	–	–	–	–	–	–	1682 <sup>6</sup>	2169	2482
17.00	–	–	–	–	–	–	–	–	2274	2645
18.00	–	–	–	–	–	–	–	–	2366	2796
19.00	–	–	–	–	–	–	–	–	2471	2935
20.00	–	–	–	–	–	–	–	–	2552 <sup>6</sup>	3051
21.00	–	–	–	–	–	–	–	–	–	3144
22.00	–	–	–	–	–	–	–	–	–	3225 <sup>6</sup>

<sup>4</sup> C<sub>v</sub> = GPM at a ΔP of 1 psi/7 kPa) through the valve at any given setting.  
1 psi = 2.31 ft. of H<sub>2</sub>O

<sup>5</sup> Only the TA Series 788 Flanged End Balancing Valve is available in 14 – 16"/DN350 – DN400 sizes.

<sup>6</sup> Full open valve.

## 5.4 PERFORMANCE

---

### Correction Factors

For liquids other than water, the flow values from the balancing wheel can be adjusted as follows:  
Divide the flow rate (as indicated by the balancing wheel) by the square root of the specific gravity.

$$\text{Actual Flow} = \frac{q_{\text{calculated}}}{\sqrt{SG}}$$

This applies to liquids having, on the whole, the same viscosity as water, i.e. most water/glycol mixtures and water/brine solutions at room temperature. At low temperatures, the viscosity increases and laminar flow may occur in certain valves. The risk increases with small valves, low settings and low differential pressures.

A computer program, HySelect, is available for calculation of pre-setting values and other applications. When the flow setting is verified or changed to the final setting, the memory stop should be set. Contact Victaulic for further information.

### Correction Factors

When  $\Delta p$  and the design flow rate are known, use the formula shown to calculate the CV value or use the graphs on page 17 – 19. The Tour & Andersson balancing wheel can also be used.

$$C_v = 1.52 \frac{q}{\sqrt{\Delta p}}$$

q in GPM,  $\Delta p$  in Ft. of H<sub>2</sub>O

$$C_v = \frac{q}{\sqrt{\Delta p}}$$

q in GPM,  $\Delta p$  in psi

A computer program, HySelect, is available from Victaulic for calculation of pre-setting values and other applications.

## 5.5 PERFORMANCE

### Accessories

#### Drain Kit Series 786-DK

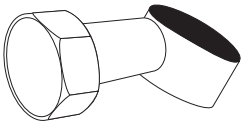

- A separate drain kit with a 3/4"/20 mm connection is available for Series 786 valves.
- Kit must be field mounted
- Kit comes complete with 2 gaskets and a hexnut.
- Partcode= K-000-786-CBV

#### NOTE

- If a drain is needed for a Series 787H or a Series 78KH, be sure to choose the valve assembly with the factory installed option. Standard Series 787H or Series 78KH valves cannot be field retrofitted.

### Probe Port

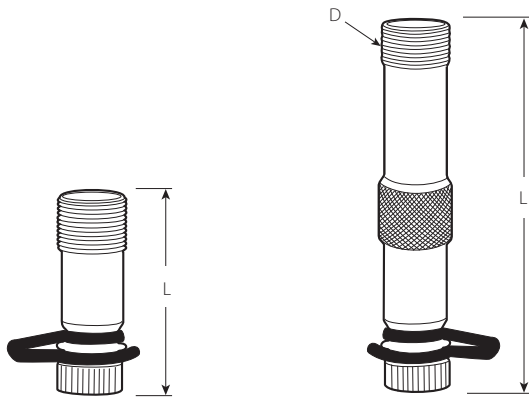

TA Series 786/787H/788/789

TA Series 788/789

Style	Size inches mm	Part Code	L inches mm
786/787H/78KH	1/2 – 2 15 – 50	K-000-740-003	1.75 45
788/789	2 1/2 – 16 65 – 400	K-000-740-002	1.19 30
788/789	2 1/2 – 16 65 – 400	K-000-740-001	3.50 89

### Universal Gauge Meter Conversion Kit

- This kit includes 2 probes, necessary fittings, flow wheel and instruction sheet.
- Partcode= K-000-738-100

### Hand Wheels

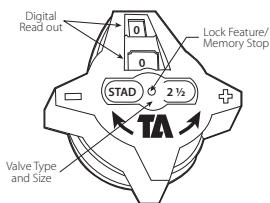

TA Series 786/787H  
Plastic  
1/2 – 2"

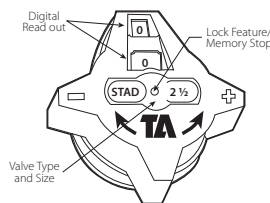

TA Series 788/789  
Plastic  
2 1/2 – 6"

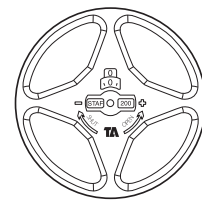

TA Series 788/789  
Aluminum  
8 – 16"

Part Code	Part Code	Part Code
P-004-784-001	P-024-784-001	P-080-784-001

5.5 PERFORMANCE (CONTINUED)

Prefab Insulation

TA Series 786 & TA Series 787H

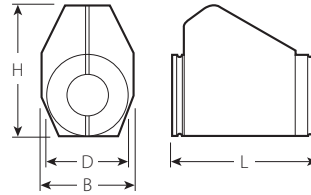

Valve Size inches mm	Part Code inches mm	Dimensions			
		H inches mm	D inches mm	B inches mm	L inches mm
1/2 & 3/4 15 & 20	K-004-784-INS	5.31 135	3.54 90	4.06 103	5.51 140
1 25	K-010-784-INS	5.59 142	3.70 94	4.06 103	6.30 160
1 1/4 32	K-012-784-INS	6.14 156	4.17 106	4.06 103	7.09 180
1 1/2 40	K-014-784-INS	6.65 169	4.25 108	4.45 113	8.43 214
2 50	K-020-784-INS	7.01 178	4.25 108	4.49 114	9.65 245

Prefab Insulation

TA Series 788 & TA Series 789

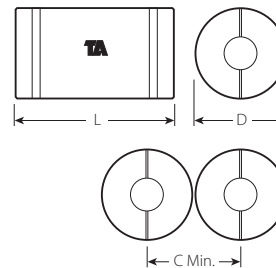

Valve Size inches mm	Part Code inches mm	Dimensions		
		L inches mm	D inches mm	C Min inches mm
2 1/2 65	K-024-784-INS	17.75 451	10.63 270	10.63 270
3 80	K-030-784-INS	19.00 483	11.44 291	11.44 291
4 100	K-040-784-INS	20.50 521	12.63 321	12.63 321
5 125	K-050-784-INS	22.50 572	13.75 349	13.75 349
6 150	K-060-784-INS	26.00 660	15.00 381	15.00 381

## 6.0 NOTIFICATIONS

### WARNING



- Read and understand all instructions before attempting to install, remove, adjust, or maintain any Victaulic piping products.
- Depressurize and drain the piping system before attempting to install, remove, adjust, or maintain any Victaulic piping products.
- Wear safety glasses, hardhat, and foot protection.

Failure to follow these instructions could result in death or serious personal injury and property damage.

## 7.0 REFERENCE MATERIALS

[08.29: Victaulic Differential Pressure Controller - TA Series 793/794](#)

[08.30: Victaulic KOIL-KIT Coil Pack](#)

[08.34: Victaulic Automatic Balancing Valves - Series 76T, 76B, 76K, 76V & 76G](#)

[08.37: Victaulic Compact Pressure Independent Balancing and Control Valve \(Compact P\) - TA Series 7CP](#)

[08.38: Victaulic TBV Terminal Balancing and Control Valves - Series TC & Series TCM](#)

[08.46: Victaulic Differential pressure Controller - TA Series 7PR](#)

[08.55: Victaulic Pressure Independent Balancing and Modulating Control Valve - TA Series 7MP](#)

### User Responsibility for Product Selection and Suitability

Each user bears final responsibility for making a determination as to the suitability of Victaulic products for a particular end-use application, in accordance with industry standards and project specifications, and the applicable building codes and related regulations as well as Victaulic performance, maintenance, safety, and warning instructions. Nothing in this or any other document, nor any verbal recommendation, advice, or opinion from any Victaulic employee, shall be deemed to alter, vary, supersede, or waive any provision of Victaulic Company's standard conditions of sale, installation guide, or this disclaimer.

### Intellectual Property Rights

No statement contained herein concerning a possible or suggested use of any material, product, service, or design is intended, or should be construed, to grant any license under any patent or other intellectual property right of Victaulic or any of its subsidiaries or affiliates covering such use or design, or as a recommendation for the use of such material, product, service, or design in the infringement of any patent or other intellectual property right. The terms "Patented" or "Patent Pending" refer to design or utility patents or patent applications for articles and/or methods of use in the United States and/or other countries.

### Note

This product shall be manufactured by Victaulic or to Victaulic specifications. Victaulic recommends all products to be installed in accordance with current IMI TA installation/assembly instructions. Victaulic and IMI TA reserve the right to change product specifications, designs and standard equipment without notice and without incurring obligations.

### Installation

Reference should always be made to the current IMI TA installation/assembly instructions for the product you are installing. For coupling and strainer installation, reference should always be made to the I-100 Victaulic Filed Installation Handbook for the product you are installing. Handbooks are included with each shipment of Victaulic products for complete installation and assembly data, and are available in PDF format on our website at [www.victaulic.com](http://www.victaulic.com)

### Warranty

Refer to the Warranty section of the current Price List or contact Victaulic for details.

### Trademarks

*Victaulic* and all other Victaulic marks are the trademarks or registered trademarks of Victaulic Company, and/or its affiliated entities, in the U.S. and/or other countries.